

TYPICAL STREET WITH DIAGONAL CROSSING

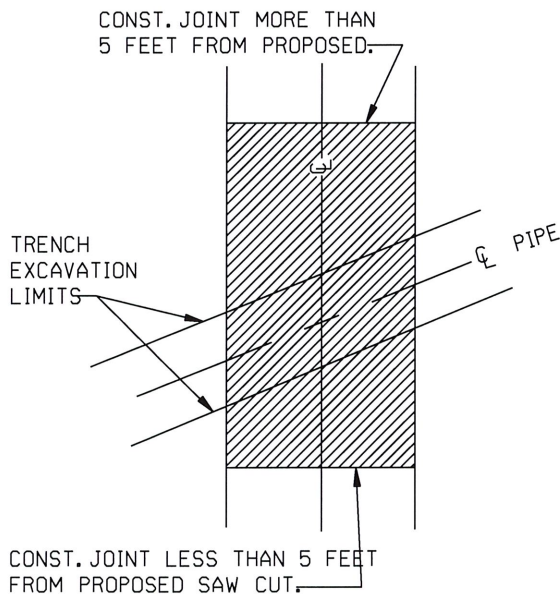

TYPICAL DRIVEWAY OR SIDEWALK WITH DIAGONAL CROSSING

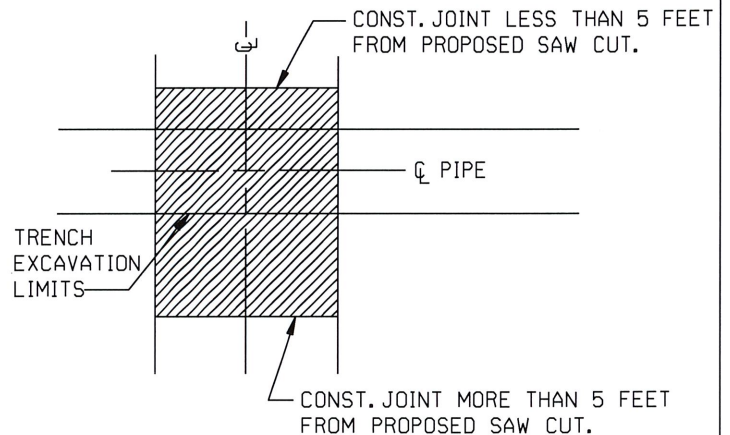

TYPICAL STREET, DRIVEWAY, OR SIDEWALK WITH RIGHT ANGLE CROSSING

NOTE:

1. REMOVE AND REPLACE PAVEMENT WITHIN SHADED AREAS BOUNDED BY CONST. JOINTS.
2. FOR DIAGONAL CROSSING, REPLACE PAVEMENT USING SQUARED JOINTS AS SHOWN. PAY QUANTITY WILL INCLUDE SQUARED AREA.
3. REMOVE AND REPLACE PAVEMENT TO CONST. JOINT IF LESS THAN 5 FEET FROM THE PROPOSED SAW CUT. EXTRA AREA WILL BE INCLUDED IN PAY QUANTITY.
4. FOR LONGITUDINAL INSTALLATIONS, REMOVE AND REPLACE PAVEMENT AND CURB TO EDGE OF STREET IF THE SAW CUT IS LESS THAN 5 FT. FROM THE OUTSIDE EDGE OF THE PAVEMENT OR CURB. AVOID SAW CUTS IN THE EXISTING WHEEL LINES. TRENCHES EXCEEDING 300 L.F. SHALL BE BACKFILLED AND MADE MORE DRIVEABLE.
5. ALL CONSTRUCTION JOINTS SHALL BE RE-ESTABLISHED IN ACCORDANCE WITH THE CITY OF TULSA STANDARDS FOR PORTLAND CEMENT CONCRETE PAVEMENT. WHEN A PAVEMENT SECTION IS REMOVED ALONG AN EXISTING LONGITUDINAL CONSTRUCTION JOINT, THE NEW PAVEMENT SHALL BE DOWELLED TO THE PAVEMENT ADJACENT TO THE JOINT.
6. MINIMUM PAVING PANEL DIMENSIONS SHALL BE 5 FEET BY 5 FEET.
7. THE MAXIMUM RATIO OF PAVING PANEL DIMENSIONS SHALL BE 1.5:1
8. JOINTS SHALL NOT BE PLACED IN VEHICLE WHEEL PATH.

STANDARD DETAIL FOR PAVEMENT CUTS	
CITY OF TULSA, OKLAHOMA ENGINEERING SERVICES DEPARTMENT	
DRAWN BY: R.M.O.	APPROVED
CHECKED BY: <i>HAS</i>	<i>[Signature]</i>
DATE: MARCH 2022	
NOT TO SCALE	STANDARD NO. 714