

PATH NAME: \\E:\PARTS\STD\DON\STD\762-PRECAST-STD-MSWRY-INLET-ACCESS-MH.DGN SBW 07/19/2012

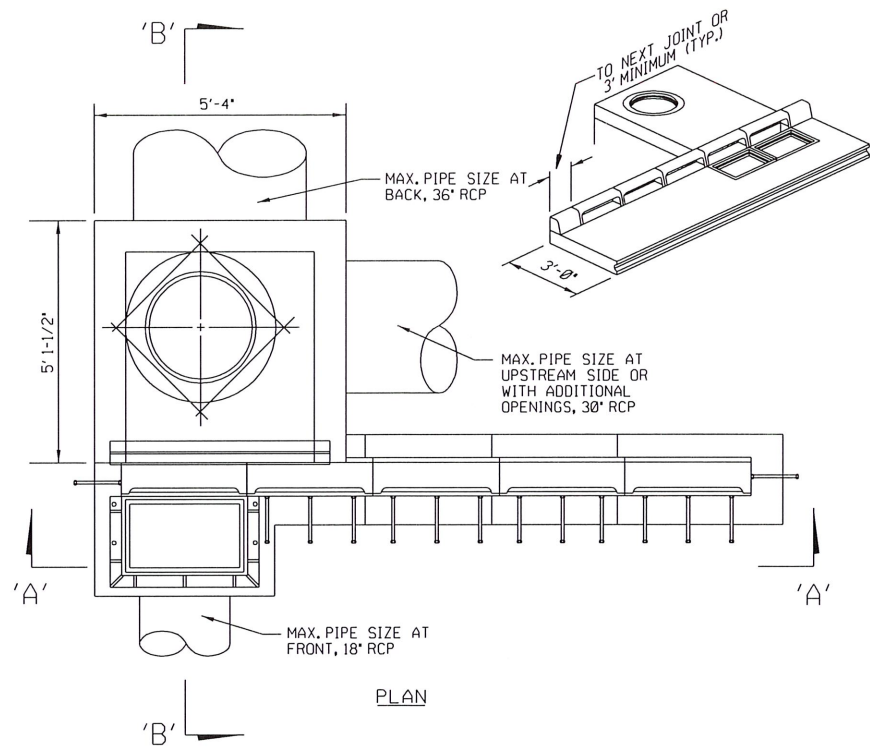

QUANTITIES FOR INLETS							
INLET DESIGN	CURB OPENING DESIGNATION	CLASS 'A' CONCRETE CU. YD.	INLET		INLET FRAME AND GRATE EACH	CAST IRON CURB INLET EACH	MH FRAME AND COVER EACH
			BASE AMT.	ADD'L. C.F. PER VERT. FT.			
1 WITH SMALL JUNCT. BOX	'A'	1.50	43.56	15.84	1	1	1
	'B'	1.60	47.34	17.43	1	2	1
	'C'	1.73	55.44	21.03	1	3	1
	'D'	1.86	62.26	24.63	1	4	1
2 WITH SMALL JUNCT. BOX	'A'	1.70	47.84	17.40	2	2	1
	'B'	1.83	57.01	21.00	2	3	1
	'C'	1.96	64.86	24.60	2	4	1
	'D'	2.08	71.70	28.20	2	5	1
1 WITH LARGE JUNCT. BOX	'A'	2.11	50.44	18.34	1	1	1
	'B'	2.21	54.22	19.93	1	2	1
	'C'	2.34	62.32	23.53	1	3	1
	'D'	2.47	69.14	27.13	1	4	1
2 WITH LARGE JUNCT. BOX	'A'	2.31	54.72	19.90	2	2	1
	'B'	2.43	63.89	23.50	2	3	1
	'C'	2.57	71.74	27.10	2	4	1
	'D'	2.69	78.58	30.70	2	5	1
2 WITH LARGE JUNCT. BOX	'A'	2.82	84.16	34.30	2	6	1
	'B'						
	'C'						
	'D'						

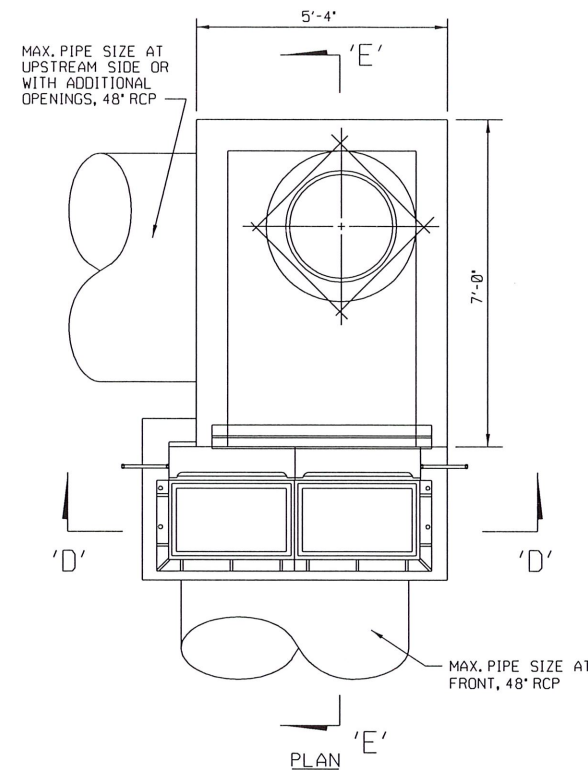

- NOTE:**
- (A) WHEN THE INLET IS BUILT IN EXISTING PAVEMENT, THE APRON AROUND THE INLET SHALL BE OF THE SIZE SHOWN IN THE PLAN ON THIS SHEET, AND BUILT OF P.C. CONCRETE TO A MINIMUM 8" THICKNESS.
 - THERE WILL BE NO DEDUCTION OF PAYMENT FOR CONCRETE CURB AND GUTTER FOR THE LENGTH OR AREA OCCUPIED BY THE CONSTRUCTION OF CAST IRON CURB INLETS OR CAST IRON CURB INLET FRAME AND GRATE.
 - RUBBER COATED REINFORCED STEEL STEPS SHALL BE PLACED AT THE HEADERS IN ALL INLETS 4' OR MORE IN DEPTH. COST OF STEPS SHALL BE INCLUDED IN THE PRICE BID FOR INLET.
 - GRATINGS AND FRAMES TO BE USED IN THIS INLET ARE SHOWN ON THE STANDARD DRAWINGS STD 765, STD 766, DESIGNATED AS "STANDARD STORM SEWER GRATES AND FRAMES."
 - THE STANDARD DRAWING DESIGNATION NO., DESIGN NO., AND NUMBER OF ADDITIONAL OPENINGS SHALL BE INDICATED ON THE PLANS.
 - COST OF STRUCTURAL STEEL I-BEAMS AND ANGLE IRON TO BE INCLUDED IN THE PRICE BID FOR INLET. ANGLE IRON SHALL CONFORM TO ASTM-A7 OR A36.
 - CASTING SHALL CONFORM TO ASTM SPECIFICATION FOR GREY IRON CASTINGS, SERIAL DESIGNATION A-48-CLASS 20.
 - NO WORDING OR MARKING OF ANY KIND OTHER THAN THOSE SHOWN ON THE PLANS WILL BE PERMITTED ON THESE CASTINGS.
 - ALL NUTS AND BOLTS REQUIRED FOR THESE STRUCTURES SHALL BE CADMIUM PLATED OR GALVANIZED.
 - CAST IRON CURBS TO BE USED ON THIS INLET ARE SHOWN ON STANDARD DRAWING DESIGNATED AS "STANDARD CAST IRON CURB."
 - ALL MORTAR JOINTS TO BE 3/8" MAXIMUM, EVERY FIFTH COURSE OF BRICK MASONRY TO BE HEADER COURSE.
 - CURB INLETS SHALL BE PLACED ON UPSTREAM SIDE OF GRATE INLETS FOR TYPICAL INSTALLATIONS.
 - CONCRETE TROUGH FOR CURB INLETS AND STORM SEWER INLETS SHALL BE CONSTRUCTED AS ONE UNIT.
 - IF PRECAST INLET IS USED, FLOWABLE FILL MUST BE USED AS BACKFILL AROUND THE ENTIRE INLET.
 - USE MANHOLE FRAME AND LID AS SHOWN ON STANDARD DRAWING NO. 754
 - MANHOLE FRAME AND LID MUST BE FLUSH WITH TOP OF THE SURROUNDING CONCRETE SLAB.
- BASES TO BE FORMED WITH 1 X 6 FORMS AND POURED IN PLACE.

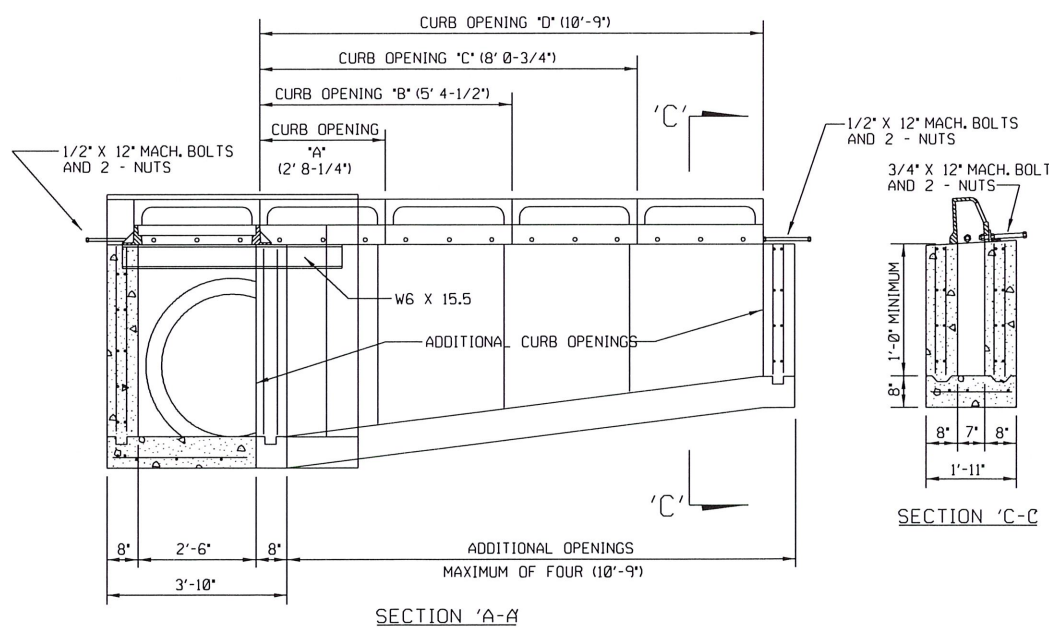

SINGLE GRATE CURB INLET WITH JUNCTION BOX
(DESIGN 1-D WITH SMALL JUNCTION BOX SHOWN)

ALL REBAR IN WALLS
#4 @ 12" CTRS. EA. WAY
(TYPICAL)

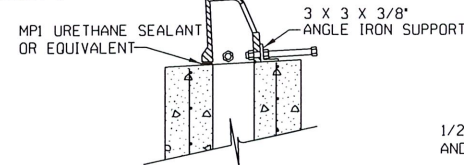

ADDITIONAL CURB OPENING DETAILS

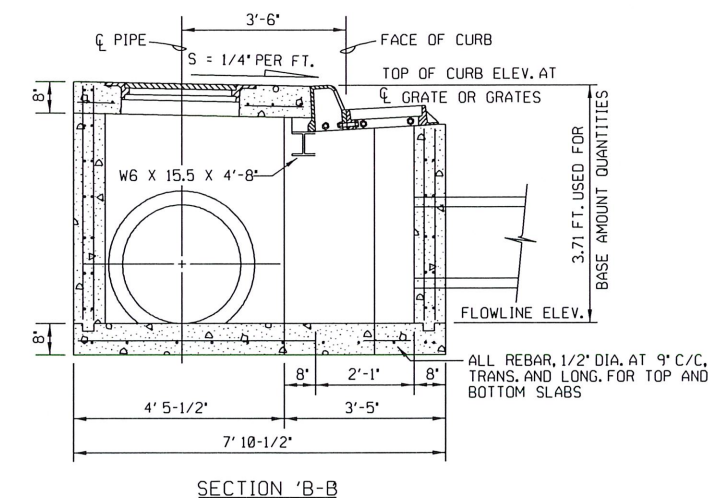

FRAME AND CURB DETAILS

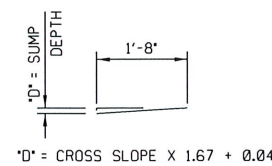

ANGLE IRON LENGTHS	
OPENING	LENGTH
'A'	2'-5-3/8"
'B'	5'-1-5/8"
'C'	7'-9-7/8"
'D'	10'-6-1/8"

C.I. CURB HEIGHTS		
TYPE	'A'	'B'
4' MOUNTABLE	4-1/2"	9-1/2"
6' MOUNTABLE	6-1/2"	11-1/2"
6' BARRIER	6-1/2"	11-1/2"
8' BARRIER	8-1/2"	13-1/2"

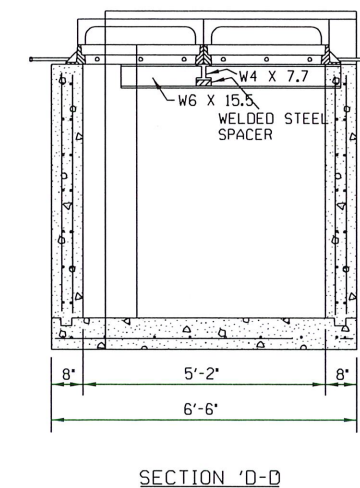

SECTION 'D-D'

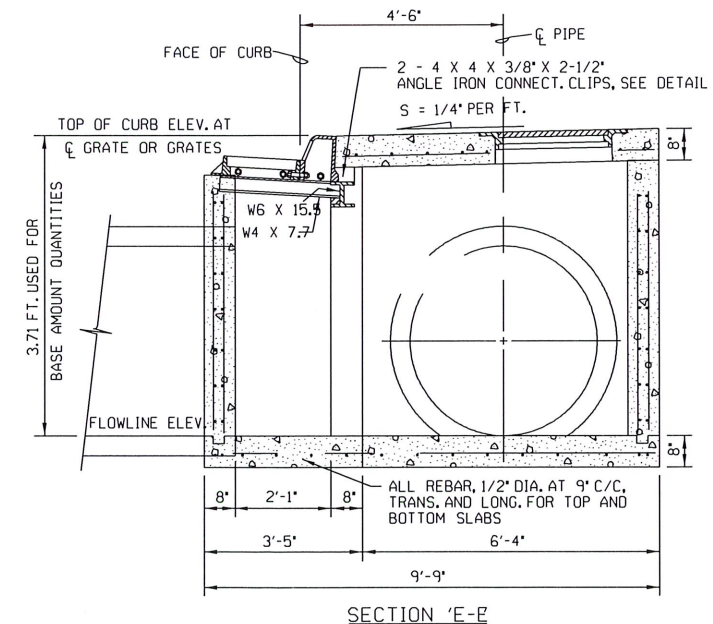

SECTION 'E-E'

DOUBLE GRATE CURB INLET WITH JUNCTION BOX
(DESIGN 2 WITH LARGE JUNCTION BOX SHOWN)
18" THRU 30" LONGITUDINAL PIPE REQUIRES SMALL JUNCTION BOX

ALL REBAR IN WALLS
#4 @ 12" CTRS. EA. WAY
(TYPICAL)

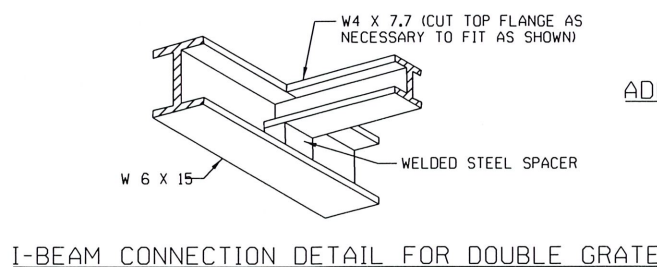

I-BEAM CONNECTION DETAIL FOR DOUBLE GRATE

BASIS OF PAYMENT		
ITEM NO.	ITEM	UNIT
6 11.06 (E)	INLET	EA.
6 11.06 (F)	ADDITIONAL DEPTH IN INLET	VERT. FT.
6 11.06 (G)	INLET FRAME AND GRATE	EA.
6 11.06 (D)	MANHOLE FRAME AND COVER	EA.
6 11.06 (K)	CAST IRON CURB INLETS	EA.

REVISION	BY	DATE

[Signature]
CITY ENGINEER

[Signature]
DESIGN MANAGER

CITY OF TULSA, OKLAHOMA
ENGINEERING SERVICES DEPARTMENT

PRECAST STANDARD
INLETS AND GRATES
W/ACCESS MANHOLE BACK OF CURB

DATE: MARCH 2022

STD. 762