

8 or 9' - ID FRP MANHOLE WITH 6' - ID PRECAST WALL SECTION AND FLAT TOP
N.T.S.

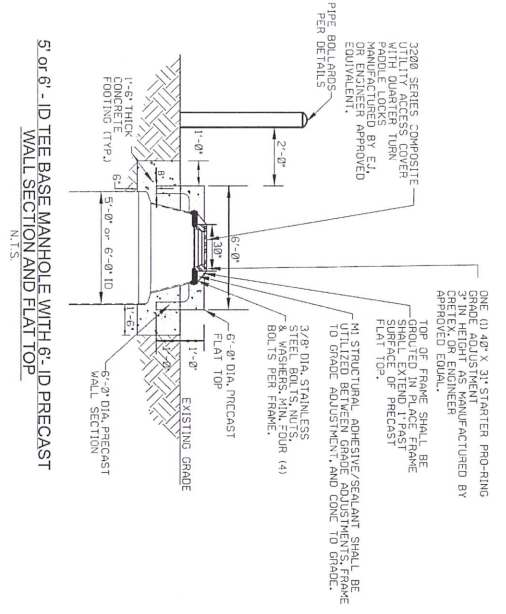

5' or 6' - ID TEE BASE MANHOLE WITH 6' - ID PRECAST WALL SECTION AND FLAT TOP
N.T.S.

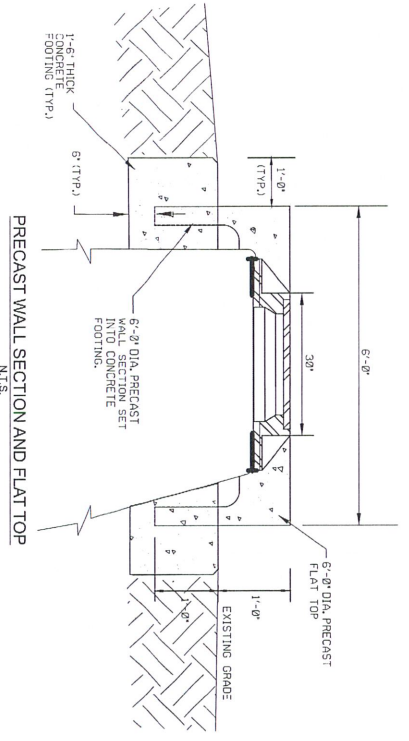

PRECAST WALL SECTION AND FLAT TOP
N.T.S.

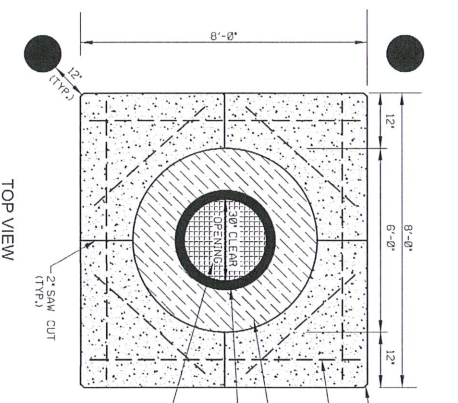

TOP VIEW
MANHOLES IN UNPAVED FLOODPLAIN AREAS
N.T.S.

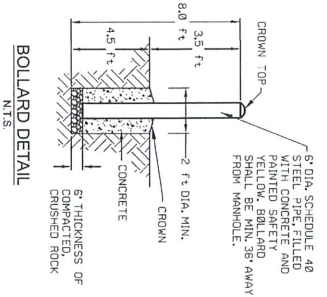

BOLLARD DETAIL
N.T.S.

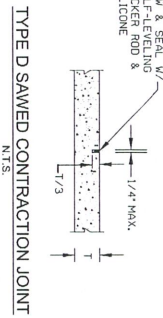

TYPE D SAWED CONTRACTION JOINT
N.T.S.

NOTE:
1. PIPE BOLLARDS SHALL BE POWDER COATED SAFETY YELLOW

REVISION	BY	DATE

CITY ENGINEER	CITY OF TULSA, OKLAHOMA
<i>[Signature]</i>	PUBLIC WORKS DEPARTMENT
DESIGN NUMBER	STANDARD ELEVATED FRP
	MANHOLE DETAILS
DATE: AUGUST 2023	STD. 369