

# Invitation for Bid (IFB)

TAC 309F

**Supplies or Services Requested:** Secondary Source for Truck Bodies, Equipment & Accessories

**Department:** Citywide

**NIGP Commodity Code(s):** 065-69; 065-45; 055-21

## Solicitation Schedule

| EVENT   | DATE  |
|---|---|
| IFB Issue Date  | 8/9/2024  |
| Pre-Bid Conference  | None  |
| Deadline for Questions<br><i>Submitted to assigned buyer via email.</i>   | 8/26/2024<br><i>10 Days prior to IFB due date</i> |
| Bid Submission Date<br><i>Either mailed or delivered to City Clerk address. Bids are open the day after the due date.</i> | 9/4/2024  |

If You have any questions or need additional information, contact the Assigned Buyer:

Julie Miller | [jamiller@cityoftulsa.org](mailto:jamiller@cityoftulsa.org)

*All questions should be emailed with TAC 309F on the subject line.*

**Submit Bids (sealed) to:**

City of Tulsa – City Clerk’s Office  
175 E. 2<sup>ND</sup> St., Suite 260  
Tulsa, OK 74103

*Bids (2 total: 1 original, 1 copy) must be sealed and either mailed or delivered. Write the Bid Number, Supplies or Service requested (as listed above), and Bid Opening Date on the lower left corner of the outside of Your Bid envelope. Feel free to use included packing slip. No faxed or emailed Bids will be considered. Barring certain circumstances (Section III-5), Bids received after the stated date and time **will not be accepted and will be returned to the Bidder unopened.***



**CITY OF**  
**Tulsa**  
A New Kind of Energy.

## I. STATEMENT OF PURPOSE:

### 1. Overview and Goals

The goal of this solicitation is to secure a Secondary Source for Truck Bodies, Equipment & Accessories for use by the City of Tulsa.

### 2. Term of Contract

The City intends to award a one-year annual contract. The City may offer the Seller the opportunity for additional one-year terms. The City also reserves the right to make multiple or partial awards. To do business with the City, You must agree to the terms and conditions of the City's standard Purchase Agreement, indicated by Your **Authorized Agent's** signature on the Purchase Agreement.

Capitalized terms used in this IFB and not defined in the Purchase Agreement shall have the meanings as ascribed to them in Title 6, Chapter 4 of the [Tulsa Revised Ordinances](#).

The entire Invitation for Bid (IFB), including any additional information submitted by Bidder and Accepted by City will be included as part of the Agreement between Seller and City. **All sheets of this IFB (including Sections I-VI) must be submitted.**

#### **Authorized Agent**

Several parts of the Bid (Affidavits, Purchase Agreement) must be signed by an **"Authorized Agent."** An **Authorized Agent** means an agent who is legally authorized to bind the Seller under the law of the state in which the Seller is legally organized. For instance, under Oklahoma law, the **Authorized Agent** for each of the following types of entities is as stated below:

- **Corporations** – the president, board chair or board vice chair (or the vice president if the corporation was formed in Oklahoma) can sign; others can sign if they have and provide the City with (i) a corporate resolution giving them authority to bind the Seller, and (ii) a recent certificate of secretary indicating the authority is still valid and was in full force and effect on the date of the signature. (See IFB Section VI for sample of a Certificate of Secretary)
- **General Partnerships** – any partner can sign to bind all partners.
- **Limited Partnerships** – the general partner must sign.
- **Individuals** – no additional authorization is required, but signatures must be witnessed and notarized.
- **Sole Proprietorship** – the owner can sign. Any other person can sign if s/he provides a recent Power of Attorney, signed by the owner, authorizing him/her to bind the sole proprietorship.
- **Limited Liability Company (LLC)** – any manager of the LLC elected by the members of the LLC, or any member signing as manager of the LLC. All other signers will need a Consent of Members signed by all the Members of the LLC authorizing their signature on or up to 30 days before the date of their signature. (See Section VI for sample of a Consent of Members)

Entities organized in states other than Oklahoma must follow the law of the state in which they are organized.

## II. SCOPE OF SERVICES AND SPECIFICATIONS

### 1. Scope of Services

The City is requesting Bids for a Secondary Source for Truck Bodies, Equipment, and Accessories when the Primary Seller is not able to meet the demands of the City of Tulsa.

#### **Delivery Requirements**

All prices quoted shall be based on delivery F.O.B. Tulsa, Oklahoma or to any other points as may be designated in the Specifications, with all charges prepaid by Seller to the actual point of delivery. Bids must state the number of Days required for delivery under normal conditions.

Absolutely no items over 500lbs. may be directly shipped to the City requiring the City personnel to unload from the shipping truck or trailer. The City carries no responsibility for any damages incurred during an unloading occurrence. All unloading shall be the responsibility of the Seller and/or shipping entity.

### 2. Specifications

The Bid **must** meet or exceed the following Specifications.

Seller shall respond to the minimum Specifications set out in the Specifications Tables below by completing the Bidder's Proposal Column – in the space provided. Whenever asked to “describe”, Your description may include details such as size, capacities, dimensions, materials used in construction, etc. A full and complete description is required to reasonably evaluate the Bid. When referring to attached literature as a means of not fully describing items, the evaluator may misinterpret Your response, and Your Bid may be rejected. Your ability to present the City with enough information to reasonably understand the item being bid and whether it meets the Specifications stated relies on the information You provide in the Specifications Tables below.

**You may not respond** in the space provided in the Bidder's Proposal Column as to whether You meet the Specifications by responding **with terms as “yes”, “Meets”, “same as”, “complies” or “similar” terms**. If these terms are utilized, Your Bid will be considered non-responsive and be rejected.

You **must include** descriptive manufacturer's literature verifying the information You provided in the Bidder's Proposal Column of the Specifications Tables below. Failure to provide such literature will result in Your Bid being considered as non-responsive and **being rejected**.

Seller shall ensure that each vehicle and related part come with a manufacturer's warranty of good material and workmanship and that the manufacturer promptly replace any part or parts which by reason of defective materials or workmanship fails under normal use, free of negligence or accident, for a minimum of one (1) year from the date of delivery. In addition, if such failures take place outside the dealer's service area, which shall be defined as Tulsa city limits, the Seller will be responsible for reimbursing the nearest manufacturer's authorized dealer in the city of Tulsa for services rendered under this warranty.

The Seller shall respond within 72 hours of notification by the City of Tulsa, on when, where and how a warranty issue will be resolved. In the event there is no response within 72 hours, or if the response is not acceptable to the City of Tulsa, the City will provide or arrange for repairs.

**The Seller shall have the option to authorize the City of Tulsa to perform minor warranty replacement and repairs and then reimburse the City for its labor and parts utilized to complete the repair. The reimbursement for labor will be at the same rate as that of the actual work performed. Standard warranty information is to be supplied with the Bid.**

**SPECIFICATIONS TABLES**

**Item 1: Crane, Remote Controlled 2,000 lb.**

| Item   | SPECIFICATIONS (Minimum)   | Bidder's Proposal   |
|--|--|---|
| <b>General Description</b>                                     | This Specification shall provide for a new Remote-Controlled Crane, the latest current production model. Auto Crane Model 2003 or equivalent. Complete with manufacturer's standard equipment and accessories, fully serviced ready to operate. To include manufacturer's certificate or warranty. (Warranty shall be the standard for the industry as offered to the public.) This crane shall be equipped to meet all Federal and State of Oklahoma Safety Standards and Requirements. | Describe:<br>Make: _____<br>Model _____<br>_____<br>_____<br>_____<br>_____<br>_____<br>_____ |
| <b>Lifting Capacity</b>  | The crane shall have the lifting capacity of 2,000 lb. as follows:<br>2,000 lbs. at 3-feet.<br>1,565 lbs. at 4-feet.<br>1,160 lbs. at 5-feet.<br>1,000 lbs. at 6-feet.<br>800 Lbs. At 7-feet.<br>760 Lbs. At 8-feet.<br>665 Lbs. At 9-feet.  | Describe:<br>_____<br>_____<br>_____<br>_____<br>_____<br>_____<br>_____                      |
| <b>Specifications &amp; Standards</b>                          | Overall dimensions (LxWxH)<br>76 ¾-inches x 19-inches x 21" approx.<br>The weight of the crane shall not exceed 385 lbs.<br>Lifting lug for transport. Compliance with ANSI B30.5 standards and OSHA regulations concerning crawler locomotives and truck cranes.<br>(OSHA Title 29, Part 1910.180)  | Describe<br>_____<br>_____<br>_____<br>_____<br>_____<br>_____                                |
| <b>Chassis Requirements (City of Tulsa to provide Chassis)</b> | Minimum truck chassis requirements: 8,500 lbs. GVWR (3/4 ton or greater truck chassis.)  | Describe:<br>_____<br>_____   |
| <b>Stabilizers</b>   | Outriggers shall be installed to increase stability and reduce the load on the truck while lifting.  | Describe:<br>_____<br>_____   |
| <b>Electrical</b>  | 22-feet of high current battery cable.   | Describe:<br>_____  |

|                              |   |   |
|------------------------------|---|---|
| <p><b>Boom – Lift</b></p>    | <p>Lift angle: 0° to 75°<br/>Six (6) working boom positions<br/>Lift cylinder manually activated via gas spring.</p>  | <p><u>Describe:</u><br/>_____<br/>_____<br/>_____</p>   |
| <p><b>Boom Extension</b></p> | <p>Manually actuated 3-boom positions lockable:<br/>A. 5-feet 6-inches<br/>B. 7-feet<br/>C. 9-feet</p>  | <p><u>Describe:</u><br/>_____<br/>A _____<br/>B _____<br/>C _____</p>                                   |
| <p><b>Hoist</b></p>          | <p>Motor – 12V DC series wound, 1.9 HP, heavy duty. The actuator must have an industrial grade gear box with worm brake 38:1 worm gear reduction with 7.84:1 spur gear reduction providing non-slip braking.<br/>Rated @ 2,000 lbs. last layer capacity.<br/>Line speed of 30 ft/min. (single line) with no load. 50-feet. of ¼-inch diameter aircraft cable with 7,000 lbs. breaking strength compliance to ANSI Standards<br/><b>(Consumer grade winch with permanent magnet motor is NOT acceptable)</b></p> | <p><u>Describe:</u><br/>_____<br/>_____<br/>_____<br/>_____<br/>_____<br/>_____<br/>_____<br/>_____</p> |
| <p><b>Sheave</b></p>         | <p>Anti-friction, high strength polymer with maintenance free, sealed needle roller bearing</p>   | <p><u>Describe:</u><br/>_____<br/>_____</p>   |
| <p><b>Swivel Block</b></p>   | <p>Heavy-duty type with hook with latch provision for double line string up.</p>  | <p><u>Describe:</u><br/>_____<br/>_____</p>   |
| <p><b>Rotation</b></p>       | <p>360° continuous manual rotation braking by means of manual handle.</p>   | <p><u>Describe:</u><br/>_____<br/>_____</p>   |
| <p><b>Control System</b></p> | <p>Handheld control to operate crane functions. Weather resistant. Allows all operations of the crane.</p>  | <p><u>Describe:</u><br/>_____<br/>_____</p>   |
| <p><b>Warranty</b></p>       | <p>The manufacturer shall provide a two-year limited warranty against defects in materials and workmanship from the date of delivery.</p>   | <p><u>Describe:</u><br/>_____<br/>_____<br/>_____</p>   |
| <p><b>Boom Support</b></p>   | <p>Shall be installed for the boom in a stowed position while in transit.</p>   | <p><u>Describe:</u><br/>_____<br/>_____</p>   |
| <p><b>Color</b></p>          | <p>Crane shall be painted the same color as the vehicle it is being mounted on.</p>   | <p><u>Describe:</u><br/>_____<br/>_____</p>   |

**Mounting Instructions:** Cranes shall be mounted by the supplier in accordance with the industry standard for such, including furnishing and installing all reinforcement needed to secure the crane in a safe manner without damage to the vehicle and its body. The body shall not tilt in any manner after installation

**NOTE:** Seller must not remove identification plates or numbers on the truck. This especially applies to the truck transmission when power take off is installed. If, during installation, it becomes necessary to remove these plates or cover these numbers, then these numbers and/or plates must be replaced in a visible location.

**ELECTRICAL WIRING:** Wiring to be in loom and properly secured to frame to prevent sagging. Upon completion of installation, all connections, splices and wiring to be protected by all-weather insulation. The insulation material to be of enough quality to insure a life period of five (5) years.

**POWER TAKE OFF (If required):** Must be the latest current model installed and/or adapted to fit the transmission. Mounting bolts or screws must provide adequate self-locking and seating to insure against oil leaks and must keep housing firmly attached to transmission. A fan belt clutch pump is to be provided for trucks with no PTO opening. Light duty trucks with Allison transmissions to use a Hot Shift PTO.

**PAINT:** All exposed metal shall be primed and painted to match vehicle.

**Item 2: Crane, Remote Controlled 2,000 lb. (Pedestal Mounted)**

| Item   | Specifications (Minimum)   | Bidder's Proposal  |
|--|--|--|
| <p><b>General Description</b></p>            | <p>This Specification shall provide for new remote-controlled cranes, the latest current production model. Complete with manufacturer's standard equipment and accessories fully serviced ready to operate. To include manufacturer's certificate or warranty. (Warranty shall be the standard for the industry as offered to the public.) This crane shall be equipped to meet all Federal and State of Oklahoma Safety Standards and Requirements.</p> | <p><u>Describe:</u></p> <hr/> <hr/> <hr/> <hr/> <hr/> <hr/> <hr/> <hr/> <hr/> <hr/>                |
| <p><b>Lifting Capacity</b></p>               | <p>The crane shall have the lifting capacity of 2,000 lbs. as follows:<br/>                 2,000 LBS. @ 3-feet 3-inches.<br/>                 1,546 LBS. @ 4-feet 2-inches.<br/>                 1,260 LBS. @ 5-feet 2-inches.</p>  | <p><u>Describe:</u></p> <p>Make: _____</p> <p>Model: _____</p> <hr/> <hr/> <hr/> <hr/> <hr/> <hr/> |
| <p><b>Specifications &amp; Standards</b></p> | <p>Overall dimensions (LxWxH) approx.<br/>                 24-inches x 11-inches x 46 5/8-inches.<br/>                 The weight of the crane shall not exceed 240 lbs.<br/>                 Paint – Factory White<br/>                 Compliance with ANSI B30.5 standards and OSHA regulations concerning crawler locomotives and truck cranes.<br/>                 (OSHA Title 29, Part 1910.180)</p>  | <p><u>Describe:</u></p> <hr/> <hr/> <hr/> <hr/> <hr/> <hr/> <hr/> <hr/> <hr/> <hr/>                |

|   |  |   |
|---|--|---|
| <b>(Chassis only to be provided by City of Tulsa)</b> | Minimum truck chassis requirements:<br>5,200 lbs. GVWR.  | <u>Describe:</u><br>_____<br>_____  |
| <b>Stabilizers</b>                                    | Stabilizers shall be installed to increase stability and reduce the load on the truck springs while lifting.   | <u>Describe:</u><br>_____<br>_____  |
| <b>Electrical</b>                                     | Battery heavy-duty, deep cycle, maintenance type. 22-foot of high current battery cable.   | <u>Describe:</u><br>_____<br>_____  |
| <b>Boom – Lift</b>                                    | Lift angle from 17-degrees to 50-degrees with two (2) working boom positions, manually activated.  | <u>Describe:</u><br>_____<br>_____  |
| <b>Boom Extension</b>                                 | Manually activated.<br>7-foot boom - 3-boom positions:<br>4-feet 2-inches<br>5-foot 7-inches<br>7-foot 0-inches  | <u>Describe:</u><br>_____<br>_____<br>_____<br>_____  |
| <b>Hoist</b>  | Hoist unit:<br>1. Motor – 12V DC series wound, 3/4 HP, heavy duty.<br>2. Hoist function shall not exceed 35 Amps when lifting maximum load of 2,000 lbs.<br>3. Hoist must incorporate a spur gear reduction (A worm gear design is NOT acceptable).<br>4. The hoist shall be equipped with a friction brake capable of holding the rated capacities in the event of power loss to the crane.<br>5. Line speed of 18 ft./min. (single line) with no load.<br>6. 25-ft. of 3/16" diameter aircraft cable with 4,200 lbs. breaking strength compliance with ANSI Standards. | <u>Describe:</u><br>1 _____<br>2 _____<br>3 _____<br>4 _____<br>5 _____<br>6 _____<br>_____ |
| <b>Sheave</b>   | Anti-friction, high strength polymer with maintenance free, sealed needle roller bearing.  | <u>Describe:</u><br>_____<br>_____  |
| <b>Boom – Lift</b>                                    | Lift angle from 17-degrees to 50-degrees with two (2) working boom positions, manually activated.  | <u>Describe:</u><br>_____<br>_____  |
| <b>Boom Extension</b>                                 | Manually activated.<br>7-foot boom - 3-boom positions:<br>4-feet 2-inches<br>5-foot 7-inches<br>7-foot 0-inches  | <u>Describe:</u><br>_____<br>_____<br>_____<br>_____  |
| <b>Hoist</b>  | Hoist unit:<br>1. Motor – 12V DC series wound, 3/4 HP, heavy duty.   | <u>Describe:</u><br><u>Hoist Unit</u><br>1 _____  |

|                       |  |   |
|-----------------------|--|---|
|                       | <ol style="list-style-type: none"> <li>2. Hoist function shall not exceed 35 Amps when lifting maximum load of 2,000 lbs.</li> <li>3. Hoist must incorporate a spur gear reduction (A worm gear design is NOT acceptable).</li> <li>4. The hoist shall be equipped with a friction brake capable of holding the rated capacities in the event of power loss to the crane.</li> <li>5. Line speed of 18 ft./min. (single line) with no load.</li> <li>6. 25-ft. of 3/16" diameter aircraft cable with 4,200 lbs. breaking strength compliance with ANSI Standards.</li> </ol> | <hr/> <hr/> 2<br><hr/> <hr/> 3<br><hr/> <hr/> 4<br><hr/> <hr/> 5<br><hr/> <hr/> 6 |
| <b>Sheave</b>         | Anti-friction, high strength polymer with maintenance free, sealed needle roller bearing.  | Describe:<br><hr/> <hr/>  |
| <b>Swivel Block</b>   | Heavy-duty type with hook with latch provision for double line string up.  | Describe:<br><hr/> <hr/>  |
| <b>Rotation</b>       | 325° continuous manual rotation braking by means of manual handle.   | Describe:<br><hr/> <hr/>  |
| <b>Control System</b> | Handheld control to operate crane functions. Must allow all operations of the crane. Weather resistant.  | Describe:<br><hr/> <hr/>  |
| <b>Warranty</b>       | The manufacturer shall provide a two-year limited warranty against defects in materials and workmanship from the date of delivery.   | Describe:<br><hr/> <hr/> <hr/>  |
| <b>Option</b>         | (1) Power Rotation & Manual Boom Elevation   | Describe:<br><hr/> <hr/>  |

**Mounting Instructions:** Cranes shall be mounted by the supplier in accordance with the industry standard for such, including furnishing and installing all reinforcement needed to secure the crane in a safe manner without damage to the vehicle and its body. The body shall not tilt in any manner after installation.

**NOTE:** Seller must not remove identification plates or numbers on the truck. This especially applies to truck transmission when power take off is installed. If, during installation, it becomes necessary to remove these plates or cover these numbers, then these numbers and/or plates must be replaced in a visible location.

**ELECTRICAL WIRING:** Wiring to be in loom and properly secured to frame to prevent sagging. Upon completion of installation all connections, splices and wiring to be protected by all-weather insulation. This insulation material to be of enough quality to insure a life period of five (5) years.

**PAINT:** All exposed metal shall be primed and painted to match vehicle.



**Item 3: Crane, Remote Controlled 3,200 lb.**

| Item  | Specifications (Minimum)  | Bidder's Proposal                                      |                         |       |            |       |            |       |            |       |            |       |            |       |            |        |            |        |          |        |          |        |          |        |          |        |          |   |
|---|---|--|-------------------------|-------|------------|-------|------------|-------|------------|-------|------------|-------|------------|-------|------------|--------|------------|--------|----------|--------|----------|--------|----------|--------|----------|--------|----------|---|
| <b>General Description</b>                            | This Specification shall provide for new Remote-Control Cranes, the latest current production model. Complete with manufacturer's standard equipment and accessories, fully serviced ready to operate. To include manufacturer's certificate or warranty. (Warranty shall be the standard for the industry as offered to the public.) This crane shall be equipped to meet all Federal and State of Oklahoma Safety Standards and Requirements.   | Describe:<br>_____<br>_____<br>_____<br>_____<br>_____ |                         |       |            |       |            |       |            |       |            |       |            |       |            |        |            |        |          |        |          |        |          |        |          |        |          |   |
| <b>Crane Rating</b>                                   | The crane shall have the lifting capacity of 3200 lbs. as follows:<br><table border="1" data-bbox="397 697 852 1108"><thead><tr><th><u>REACH</u></th><th><u>LIFTING CAPACITY</u></th></tr></thead><tbody><tr><td>3 FT.</td><td>3,200 Lbs.</td></tr><tr><td>4 FT.</td><td>2,500 Lbs.</td></tr><tr><td>5 FT.</td><td>2,000 Lbs.</td></tr><tr><td>6 FT.</td><td>1,670 Lbs.</td></tr><tr><td>7 FT.</td><td>1,500 Lbs.</td></tr><tr><td>9 FT.</td><td>1,100 Lbs.</td></tr><tr><td>10 FT.</td><td>1,000 Lbs.</td></tr><tr><td>11 Ft.</td><td>900 Lbs.</td></tr><tr><td>12 Ft.</td><td>830 Lbs.</td></tr><tr><td>13 Ft.</td><td>770 Lbs.</td></tr><tr><td>14 Ft.</td><td>710 Lbs.</td></tr><tr><td>15 Ft.</td><td>660 Lbs.</td></tr></tbody></table> | <u>REACH</u>   | <u>LIFTING CAPACITY</u> | 3 FT. | 3,200 Lbs. | 4 FT. | 2,500 Lbs. | 5 FT. | 2,000 Lbs. | 6 FT. | 1,670 Lbs. | 7 FT. | 1,500 Lbs. | 9 FT. | 1,100 Lbs. | 10 FT. | 1,000 Lbs. | 11 Ft. | 900 Lbs. | 12 Ft. | 830 Lbs. | 13 Ft. | 770 Lbs. | 14 Ft. | 710 Lbs. | 15 Ft. | 660 Lbs. | Describe:<br>_____<br>_____<br>_____<br>_____<br>_____<br>_____<br>_____<br>_____<br>_____<br>_____<br>_____<br>_____ |
| <u>REACH</u>  | <u>LIFTING CAPACITY</u>   |  |                         |       |            |       |            |       |            |       |            |       |            |       |            |        |            |        |          |        |          |        |          |        |          |        |          |   |
| 3 FT.   | 3,200 Lbs.  |  |                         |       |            |       |            |       |            |       |            |       |            |       |            |        |            |        |          |        |          |        |          |        |          |        |          |   |
| 4 FT.   | 2,500 Lbs.  |  |                         |       |            |       |            |       |            |       |            |       |            |       |            |        |            |        |          |        |          |        |          |        |          |        |          |   |
| 5 FT.   | 2,000 Lbs.  |  |                         |       |            |       |            |       |            |       |            |       |            |       |            |        |            |        |          |        |          |        |          |        |          |        |          |   |
| 6 FT.   | 1,670 Lbs.  |  |                         |       |            |       |            |       |            |       |            |       |            |       |            |        |            |        |          |        |          |        |          |        |          |        |          |   |
| 7 FT.   | 1,500 Lbs.  |  |                         |       |            |       |            |       |            |       |            |       |            |       |            |        |            |        |          |        |          |        |          |        |          |        |          |   |
| 9 FT.   | 1,100 Lbs.  |  |                         |       |            |       |            |       |            |       |            |       |            |       |            |        |            |        |          |        |          |        |          |        |          |        |          |   |
| 10 FT.  | 1,000 Lbs.  |  |                         |       |            |       |            |       |            |       |            |       |            |       |            |        |            |        |          |        |          |        |          |        |          |        |          |   |
| 11 Ft.  | 900 Lbs.  |  |                         |       |            |       |            |       |            |       |            |       |            |       |            |        |            |        |          |        |          |        |          |        |          |        |          |   |
| 12 Ft.  | 830 Lbs.  |  |                         |       |            |       |            |       |            |       |            |       |            |       |            |        |            |        |          |        |          |        |          |        |          |        |          |   |
| 13 Ft.  | 770 Lbs.  |  |                         |       |            |       |            |       |            |       |            |       |            |       |            |        |            |        |          |        |          |        |          |        |          |        |          |   |
| 14 Ft.  | 710 Lbs.  |  |                         |       |            |       |            |       |            |       |            |       |            |       |            |        |            |        |          |        |          |        |          |        |          |        |          |   |
| 15 Ft.  | 660 Lbs.  |  |                         |       |            |       |            |       |            |       |            |       |            |       |            |        |            |        |          |        |          |        |          |        |          |        |          |   |
| <b>Specifications &amp; Standards</b>                 | Overall dimensions (LxWxH) approx. 110-inches x 19.50-inches x 24-inches.<br>The weight of crane shall not exceed 680 lbs.<br>Paint- Factory White.<br>Compliance with ANSI B30.5 standards and OSHA regulations concerning crawler locomotives and truck cranes. (OSHA Title 29, Part 1910.180).   | Describe:<br>_____<br>_____<br>_____<br>_____<br>_____ |                         |       |            |       |            |       |            |       |            |       |            |       |            |        |            |        |          |        |          |        |          |        |          |        |          |   |
| <b>(Chassis Only to be provided by City of Tulsa)</b> | Minimum truck requirements:<br>Chassis 11,000 lbs. GVW Approx.  | Describe:<br>_____<br>_____                            |                         |       |            |       |            |       |            |       |            |       |            |       |            |        |            |        |          |        |          |        |          |        |          |        |          |   |
| <b>Stabilizers</b>                                    | Outriggers shall be installed to increase stability and reduce the load on the truck springs while lifting.   | Describe:<br>_____<br>_____                            |                         |       |            |       |            |       |            |       |            |       |            |       |            |        |            |        |          |        |          |        |          |        |          |        |          |   |
| <b>Electrical</b>                                     | Twenty-two (22) ft of high current battery cable.   | Describe:<br>_____                                     |                         |       |            |       |            |       |            |       |            |       |            |       |            |        |            |        |          |        |          |        |          |        |          |        |          |   |
| <b>DC Power Unit</b>                                  | Electro-hydraulic system consists of an electric motor driving hydraulic pump which provides fluid power to:<br>1. Boom Lift / Lower.<br>2. First Section Boom Extension / Retraction (on   | Describe:<br>_____<br>1 _____<br>2 _____               |                         |       |            |       |            |       |            |       |            |       |            |       |            |        |            |        |          |        |          |        |          |        |          |        |          |   |



|                              |  |  |
|------------------------------|--|--|
|                              | <p>PRX version only).</p> <p>3. Electric motor – 12V DC series wound.</p> <p>Hydraulic:</p> <p>1. Gear pump, .065 cu. in/rev. displacement</p> <p>2. 1.5 gal. nominal-capacity reservoir.</p> <p>3. System: Set full bypass relief @ 2,200 psi.</p> <p>4. Output: 1.0 GPM minimum @ 1,750 psi. @ 150 amps max.</p>   | <p>3 _____</p> <p>1 _____</p> <p>2 _____</p> <p>3 _____</p> <p>4 _____</p>   |
| <p><b>Boom – Lift</b></p>    | <p>1. Hydraulically actuated.</p> <p>2. Lift angle from -5-degrees to 75-degrees.</p> <p>3. Lift cylinder:</p> <p>4. Double acting for smooth boom operation.</p> <p>5. Counterbalance valve incorporated preventing unintentional boom dropping in the event of a hose failure.</p> <p>6. Load sensing in lift circuit: Pressure switch type sensing</p> <p>7. (Audible sensors are not acceptable.)</p> <p>8. In overload condition, disable only hoist up, boom extend and boom down functions. Other functions shall remain operable.</p>            | <p>Describe:</p> <p>1 _____</p> <p>2 _____</p> <p>3 _____</p> <p>4 _____</p> <p>5 _____</p> <p>6 _____</p> <p>7 _____</p> <p>8 _____</p> |
| <p><b>Boom Extension</b></p> | <p>Hydraulically actuated by means of extension cylinder (see information below) from 7-feet to 11-feet and manually actuated from 11-feet to 15-feet.</p> <p><u>Extension cylinder:</u></p> <p>Trunnion mounted inside boom to protect from external damage. Double acting for smooth operation and incorporates a counterbalance valve to prevent unintentional boom retraction in the event of a hose failure</p>   | <p>Describe:</p> <p>_____</p> <p>_____</p> <p>_____</p> <p>_____</p> <p>_____</p> <p>_____</p> <p>_____</p> <p>_____</p>                 |
| <p><b>Hoist</b></p>          | <p><u>Hoist unit:</u></p> <p>1. Motor – 12-Volt DC series wound, 1.9 HP, heavy duty. The actuator must have an industrial grade gear box with worm brake.</p> <p>2. 38:1 worm gear reduction with 7.84:1 spur gear reduction.</p> <p>3. Rated @ 1,600 lbs. last layer capacity.</p> <p>4. Line speed of 30-feet. /min. (single line) with no load</p> <p>5. 62-feet. of 7/32-inch diameter aircraft cable with 5,600 lbs. breaking strength compliance to ANSI Standards.</p> <p>Consumer grade winch with permanent magnet motor is NOT acceptable.</p> | <p>Describe:</p> <p>1 _____</p> <p>2 _____</p> <p>3 _____</p> <p>4 _____</p> <p>5 _____</p> <p>_____</p> <p>_____</p> <p>_____</p>       |
| <p><b>Sheave</b></p>         | <p>Anti-friction, high strength polymer with maintenance free, sealed needle bearings.</p>   | <p>Describe:</p> <p>_____</p> <p>_____</p>   |
|                              |  | <p>Describe:</p> <p>_____</p>  |

|                                 |  |  |
|---------------------------------|--|--|
| <b>Anti-two-block Preventer</b> | A bail type to reduce crown to hook distance.<br>(Hanging block two-block sensor is NOT acceptable.)<br>When activated, shall disable hoist up, boom down and extend out functions. Bail should be located on the left side of the boom to protect it from tree limbs, etc. while traveling. Cable shall be contained in a high impact plastic case with a spring-loaded cable reel. | _____<br>_____<br>_____<br>_____<br>_____              |
| <b>Swivel Block</b>             | Heavy-duty type with hook with latch.<br>Provision for double line string up.  | Describe:<br>_____<br>_____                            |
| <b>Rotation</b>                 | 360° continuous rotation.<br>40:1 worm gear set.<br>Provision for adjusting backlash between worm & gear.<br>(Non-adjustable gear set is NOT acceptable.)<br>Turntable style slew bearings.<br>Cycle speed – 34 sec. no load.  | Describe:<br>_____<br>_____<br>_____<br>_____<br>_____ |
| <b>Hydraulic Valve System</b>   | Bang-bang control with manual overrides<br>Main valve – Mono-block type with individual cartridge valves for the crane functions for easy accessibility and serviceability.<br>See more information in the DC Power Unit Section previously.   | Describe:<br>_____<br>_____<br>_____<br>_____          |
| <b>Control System</b>           | Handheld control to operate crane functions.<br>Weather resistant.<br>Allows all operations of the crane.  | Describe:<br>_____<br>_____<br>_____                   |
| <b>Boom Support</b>             | Shall be installed for the boom in a stowed position while in transit.   | Describe:<br>_____<br>_____                            |
| <b>Telescopic Outriggers</b>    | Manual In/Out Hydraulic Up/Down Outrigger Assy. for curbside crane.  | Describe:<br>_____<br>_____                            |
| <b>Warranty</b>                 | The manufacturer shall provide a two-year limited warranty against defects in materials and workmanship from the date of delivery.   | Describe:<br>_____<br>_____<br>_____                   |
| <b>Options</b>                  | <ol style="list-style-type: none"> <li>1. Outriggers: Power up/down, power in/out outriggers.</li> <li>2. Control System-Wireless. Allows all operations of the crane.</li> </ol>  | Describe:<br>1 _____<br>2 _____<br>_____               |

**MOUNTING INSTRUCTIONS:** Cranes shall be mounted by the supplier in accordance with the industry standard for such, including furnishing and installing all reinforcement needed to secure the crane in a safe manner without damage to the vehicle and its body. The body shall not tilt in any manner after installation.

**NOTE:** Seller must not remove identification plates or numbers on the truck. This especially applies to the truck transmission when power take off is installed. If, during installation, it becomes necessary to remove these plates or cover these numbers, then these numbers and/or plates must be replaced in a visible location.

**ELECTRICAL WIRING:**

Wiring to be loom and properly secured to frame to prevent sagging. Upon completion of installation, all connections, splices and wiring to be protected by all-weather insulation. This insulation material to be of enough quality to insure a life period of five (5) years.

**Item 4: Crane, Remote Controlled 5,000 lb.**

| Item  | Specifications (Minimum)   | Bidder's Proposal   |
|---|--|---|
| <b>General Description</b>                            | This Specification shall provide for new Remote-Control Cranes, the latest current production model. Complete with manufacturer's standard equipment and accessories, fully serviced ready to operate. To include manufacturer's certificate or warranty (Warranty shall be the standard for the industry as offered to the public.) This crane shall be equipped to meet all Federal and State of Oklahoma Safety Standards and Requirements. | <u>Describe:</u><br>_____<br>_____<br>_____<br>_____<br>_____<br>_____<br>_____ |
| <b>Lifting Capacity:</b>                              | The crane shall have the lifting capacity of 5,000 lbs. as follows:<br>5,000 lbs. @ 5 feet.<br>3,125 lbs. @ 8 feet.<br>2,500 lbs. @ 10 feet.<br>2,083 lbs. @ 12 feet.<br>1,785 lbs. @ 14 feet.<br>1,562 lbs. @ 16 feet.<br>1,388 lbs. @ 18 feet.<br>1,250 lbs. @ 20 feet   | <u>Describe:</u><br>_____<br>_____<br>_____<br>_____<br>_____<br>_____<br>_____ |
| <b>Specifications &amp; Standards</b>                 | Overall dimensions (LxWxH) 151.44" x 23" x 33.20" (with antenna down)<br>Weight of crane shall not exceed 1,390 lbs.<br>Compliance with ANSI B30.5 standards and OSHA regulations concerning crawler locomotives and truck cranes. (OSHA Title 29, Part 1910.180)  | <u>Describe:</u><br>_____<br>_____<br>_____<br>_____<br>_____                   |
| <b>(Chassis only to be provided by City of Tulsa)</b> | Minimum truck chassis of 14,500 lbs. GVWR. 300,000 in-lbs. RBM required.   | <u>Describe:</u><br>_____<br>_____  |
| <b>Stabilizers</b>                                    | Outriggers shall be installed to increase stability and reduce the load on the truck springs while lifting<br>Manual in & out, power up and down outrigger assy.<br>For curb-side crane  | <u>Describe:</u><br>_____<br>_____<br>_____<br>_____                            |
| <b>Paint</b>  | Paint: Factory White to match body.  | <u>Describe:</u><br>_____   |
| <b>Boom – Lift</b>                                    | Hydraulically actuated<br>A. Lift angle from -5° to 75°<br><u>Lift cylinder:</u><br>Double acting for smooth boom operation.   | <u>Describe:</u><br>_____<br>_____<br>_____<br>_____                            |

|  |  |   |
|--|--|---|
|  | <p>Counterbalance valve incorporated preventing unintentional boom dropping in the event of a hose failure.</p> <p><u>Load sensing in lift circuit:</u><br/>Pressure transducer type sensing (Audible sensors are not acceptable). Automatically reduce rotation speed while under load. In overload condition, disable only hoist up, boom extend and boom down functions. Other functions shall remain operable.</p> | <hr/> <hr/> <hr/> <hr/> <hr/> <hr/> <hr/> <hr/> <hr/> <hr/>                         |
| <p><b>Extension</b></p>                | <p>Hydraulically actuated:<br/>A. Extend from 10 to 20 feet.</p> <p><u>Extension cylinder:</u><br/>Trunnion mounted inside boom to protect from external damage.<br/>Double acting for smooth boom operation and Incorporates a counterbalance valve to prevent unintentional boom retraction in the event of a hose failure.</p>  | <p><u>Describe:</u></p> <hr/> <hr/> <hr/> <hr/> <hr/> <hr/> <hr/> <hr/> <hr/> <hr/> |
| <p><b>Hoist</b></p>                    | <p>Hydraulically motor-driven planetary gear reduction with a load holding brake<br/>Rated @ 2,500 lbs. last layer capacity<br/>Line speed of 60 feet/min. (single line) with no load.<br/>80-ft of 5/16-inch diameter aircraft cable with 9,800 lbs. breaking strength</p>  | <p><u>Describe:</u></p> <hr/> <hr/> <hr/> <hr/> <hr/> <hr/> <hr/> <hr/> <hr/> <hr/> |
| <p><b>Sheave</b></p>                   | <p>Anti-friction, high strength polymer with maintenance free, sealed needle bearings</p>  | <p><u>Describe:</u></p> <hr/> <hr/> <hr/> <hr/> <hr/> <hr/> <hr/> <hr/> <hr/> <hr/> |
| <p><b>Anti-two-block Preventer</b></p> | <p>A bail type to reduce crown to hook distance. (Hanging block two-block sensor is not acceptable.)<br/>When activated, shall disable hoist up, boom down and extend out functions<br/>Located on the left side of the boom to protect it from tree limbs, etc. while traveling<br/>Cable shall be contained in a high impact plastic case with a spring-loaded cable reel</p>  | <p><u>Describe:</u></p> <hr/> <hr/> <hr/> <hr/> <hr/> <hr/> <hr/> <hr/> <hr/> <hr/> |
| <p><b>Rotation</b></p>                 | <p>Hydraulically actuated<br/>370° non-continuous rotation<br/>Two speeds<br/>(automatically switched under load):<br/>99 sec. Unloaded; 197 sec. loaded.<br/>Sealed turntable style (worm gear) slew bearings.<br/>Home switch for stowing position.</p>  | <p><u>Describe:</u></p> <hr/> <hr/> <hr/> <hr/> <hr/> <hr/> <hr/> <hr/> <hr/> <hr/> |
| <p><b>Hydraulic System</b></p>         | <p>8-GPM flow @ 2,750 psi.<br/>(A hydraulic power source shall be provided if an adequate system is not already on the vehicle.)<br/>Full proportional control with manual overrides.</p>  | <p><u>Describe:</u></p> <hr/> <hr/> <hr/> <hr/> <hr/> <hr/> <hr/> <hr/> <hr/> <hr/> |

|                            |   |   |
|----------------------------|---|---|
|                            | <p>Main valve:<br/>Mono-block type with individual cartridge valves for the crane functions for easy accessibility and serviceability.<br/>The proportional cartridge shall control the speed of each crane function.</p>               | <hr/> <hr/> <hr/> <hr/> <hr/> <hr/>                         |
| <b>Control System</b>      | <p>Handheld remote control to operate crane functions that allows all operations of the crane.<br/>Controller shall have 4-digit LED readout providing the operator with feedback to allow explanation of current operating status.</p> | <p><u>Describe:</u></p> <hr/> <hr/> <hr/> <hr/> <hr/> <hr/> |
| <b>Boom Support</b>        | <p>Shall be installed for the boom in a stowed position while in transit.</p>   | <p><u>Describe:</u></p> <hr/> <hr/> <hr/> <hr/> <hr/> <hr/> |
| <b>Hydraulic Reservoir</b> | <p>Standard 10-gallon. hydraulic reservoir with strainer, return filter and sight gauge with hoses and fittings. (15.5-inches W x 11.4-inches D X 15.4-inches H). Sizes approx.</p>   | <p><u>Describe:</u></p> <hr/> <hr/> <hr/> <hr/> <hr/> <hr/> |
| <b>Warranty</b>            | <p>Manufacturer shall provide a two-year limited warranty against defects in materials and workmanship from the date of delivery</p>  | <p><u>Describe:</u></p> <hr/> <hr/> <hr/> <hr/> <hr/> <hr/> |
| <b>Options</b>             | <p>1. Power in/out, power up/down outriggers for curb-side crane.</p>   | <p><u>Describe:</u></p> <hr/> <hr/> <hr/> <hr/> <hr/> <hr/> |

**MOUNTING INSTRUCTIONS:** Cranes shall be mounted by the Seller in accordance with the industry standard for such including furnishing and installing all reinforcement need to secure the crane in a safe manner without damage to the vehicle and its body. The body shall not tilt in any manner after installation.

**NOTE:** Seller MUST NOT remove identification plates or numbers on the truck. This especially applies to the truck transmission when power take-off is installed. If, during installations, it becomes necessary to remove these plates or cover these numbers, then these numbers and/or plates must be replaced in a visible location.

**ELECTRICAL WIRING:** Wiring to be in loom and properly secured to frame to prevent sagging. Upon completion of installation all connections, splices and wiring to be protected by all-weather installation. This installation material to be of enough quality to insure a life period of five (5) years.

**POWER TAKE-OFF:** (required) must be the latest current model installed and/or adapted to fit the transmission. Mounting bolts or screws must provide adequate self-locking and sealing to insure against oil leaks and must keep housing firmly attached to transmission. A fan belt clutch pump is to be provided for trucks with no PTO opening. Light duty trucks with Allison transmissions to use a Hot Shift PTO.

**PAINT:** All exposed metal shall be primed and painted to match vehicle.

**Item 5: LED Strobe Systems**

| Item                                  | Specifications (Minimum)  | Bidder's Proposal   |
|---------------------------------------|---|---|
| General Description                   | <p>1. <b>REAR:</b> Vehicles shall have two (2) Whelen model VTX609C or acceptable equal, led ultra-small vertex self-contained hemispheric light assemblies in clear lens for installation of one each in rear taillights. Lights are approx. 1” tall. Assembly to contain 9 ft of wiring with an inline combination lamp driver and flasher. If the rear taillights are unable to accommodate the unit. Lights to be mounted in the bumper area.</p> <p>2. <b>Front:</b> vehicles shall have two (2) Whelen led 500 series tir6 model 50co3zcr or acceptable equal with clear lens and a model 5tsmab black surface mount adapter for horizontal mounting. Include the tir6 scan-lock flash pattern capability. Include the synch interconnect wire allowing up to eight (8) light heads to be synchronized together. Include a minimum of 6 ft of wiring. Mount the lights in the grill area if the head lights will not accommodate the units.</p> <p>The control center module mounted in the cab will have user selectable flash patterns.</p> <p><b><u>Any system bid which is not the Whelen system specified must be reviewed and approved by the City of Tulsa prior to bidding. Please send questions to the Buyer.</u></b></p> | Describe:<br>Rear _____<br>_____<br>_____<br>_____<br>_____<br>_____<br>_____<br>_____<br>_____<br>Front _____<br>_____<br>_____<br>_____<br>_____<br>_____<br>_____<br>_____<br>_____<br>_____ |
| Vehicle Mounting To Be The Following: | Option:<br>A. Cars, front and rear.<br>B. Pickups (6,000 GVW to 8,500 GVW), front and rear.<br>C. Vans, front and rear.<br>D. SUV’s, front and rear.<br>E. Trucks with utility service bodies (8,500 GVW to 18,000 GVW), front and rear.<br>F. Trucks with trucks utility service bodies (19,000 GVW to 33,000 GVW), front and rear.<br>G. Trucks with contractor’s beds (10,000 GVW to 18,000 GVW), front and rear.<br>H. Trucks with contractor’s beds (19,000 GVW to 33,000 GVW), front and rear.<br>I. Trucks with stake body flatbeds (10,000 GVW to 18,000 GVW), front and rear.<br>J. Trucks with stake body flatbeds (19,000 GVW to 33,000 GVW), front and rear.<br>K. Heavy cab & chassis trucks, <b>front only!</b> (33,000 GVW to 120,000 +GVW).<br>L. <u>Dump bodies and service bodies. Rear only mount:</u>   | Describe:<br>A _____<br>B _____<br>C _____<br>D _____<br>E _____<br>F _____<br>G _____<br>H _____<br>I _____<br>J _____<br>K _____<br>L _____<br>_____<br>_____                                 |



|  |  |   |
|--|--|---|
|  | <p>The amber strobe system described herein shall be fully assembled, installed and operational at the top and on each side, post facing rearward on the rear of 5 cu. Yard, and up, dump bodies, steel, plastic, rip rap, dump bodies and utility service bodies. All lights shall be mounted so as not to be easily damaged during the normal course of work. The strobe system shall be the same as or equal to the Whelen model vtx609c or acceptable equal, led ultra-small vertex self-contained hemispheric light assemblies in an amber lens for installation of one each in extra rear lights on the dump bodies and service bodies. The LED lights are approx. 1" tall and mounted behind amber lensed lights. Assembly to contain 9 ft of wiring with an inline combination lamp driver and flasher.</p> <p><b><u>Any system bid which is not the Whelen system specified must be reviewed and approved by the City of Tulsa prior to bidding. Contact the buyer with questions. Contact the buyer with any questions.</u></b></p> <p>The control center module mounted in the cab will have user selectable flash patterns.</p> <p>M. Not installed walk out the door price for item 1 above; Whelen vtx609c with wiring.</p> <p>N. Not installed walk out the door price for item 2 above; Whelen 500 series tir6 model 50c03zcr with wiring.</p> | <hr/> <hr/> <hr/> <hr/> <hr/> <hr/> <hr/> <hr/> <hr/> <hr/> <hr/> <hr/> <hr/> <hr/> <hr/> <hr/> <hr/> <hr/> <hr/> <hr/> <hr/> <hr/> <hr/> <hr/> <hr/> <hr/> |
|--|--|---|

**Item 6: Toolboxes**

| Item                       | Specifications (Minimum)   | Bidder's Proposal  |
|----------------------------|--|--|
| <b>General Description</b> | <ol style="list-style-type: none"> <li>1. Construction: All Steel, 14 Gauge, full arc welds.</li> <li>2. Handles: Stainless Steel Paddle Handles with Key locks, stainless steel Hinges.</li> <li>3. Keys: Two (2) sets per box shall be furnished.</li> <li>4. Lids: Spring Assist.</li> <li>5. Doors: Double Panel (14 gauge), Chain supported.</li> <li>6. Hinges: Tamper Proof.</li> <li>7. Tool Trays: Shall be included.</li> <li>8. Color: Manufacturer's Standard White powder coat finish.</li> </ol> | Describe:<br>1 <hr/> 2 <hr/> 3 <hr/> 4 <hr/> 5 <hr/> 6 <hr/> 7 <hr/> 8 <hr/> |
| <b>Item Description</b>    | Manufacturer's Model # for Reference purposes only.<br>All items shall meet or exceed.   | Describe:<br><hr/> <hr/>   |





| Options |   | Describe:                    |
|---------|---|------------------------------|
|         | A. Double lid cross box, Approx. 59-3/4-inches L x 69-1/2-inches Overall L. x 16-1/2-inches D x 20-inches W. For full size pickups (Fleetside). RKI model ST63 or equal.                    | A<br>_____<br>_____<br>_____ |
|         | B. Double lid (wide deep) cross box. Approx. 59-3/4-inches L x 69-1/2-inches Overall L. x 25-1/2-inches D x 30-inches W. For full size pickups. (Fleetside type). RKI model ST63WD or equal | B<br>_____<br>_____<br>_____ |
|         | C. Double lid cross box. Approx. 59-3/4-inches L x 69-1/2-inches Overall L. x 16-1/2-inches D x 30-inches W. For full size pickups. (Fleetside Type). RKI model ST63W or equal.             | C<br>_____<br>_____<br>_____ |
|         | D. Double lid cross box. Approx. 37-1/2-inches L x 62-1/2-inches Overall L x 17-inches deep x 20-inches W. For mid-size trucks (Fleetside), RKI model ST56U or equal.                       | D<br>_____<br>_____<br>_____ |
|         | E. Single lid box. Approx. 69-7/8-inches L x 17-1/4-inches D x 20-inches W. For full size pickups (Fleetside), RKI model C63 or equal.  | E<br>_____<br>_____<br>_____ |
|         | F. Single lid box. Low profile. Approx. 63-inches L x 13.5-inches D x 19.25-inches W. For Mid-size trucks (Fleetside). UWS model UWSTBS63ALPBLK or equal.                                   | F<br>_____<br>_____<br>_____ |
|         | G. Single lid box. Approx. 62-1/2-inches L x 17-1/4-inches D x 20-inches W. For mid-size pickups (Fleetside). RKI model C56 or equal.   | G<br>_____<br>_____<br>_____ |
|         | H. Upper side box. Approx. 78-inches L x 16-1/2-inches D x 12-1/2-inches W. Two Doors. RKI model US78C or equal   | H<br>_____<br>_____<br>_____ |
|         | I. Upper side box. Approx. 90-inches L x 16-1/2-inches D x 12-1/2-inches W. Two door. RKI model US90C or equal.   | I<br>_____<br>_____<br>_____ |
|         | J. Upper side box. Approx. 96-inches L x 16-1/2-inches x 12-1/2-inches W. Two doors. RKI model US96C or equal.  | J<br>_____<br>_____<br>_____ |
|         | K. Underbody box. Approx. 24-inches L x14-inches D x 16-inches W. One door. Frame mounted and welded to crossmembers. RKI model H241416 or equal.   | K<br>_____<br>_____<br>_____ |
|         | L. Underbody box. Approx. 24-inches L x18-inches D x 18-inches W. One door. Frame mounted and welded to crossmembers. RKI model H241818 or equal.   | L<br>_____<br>_____<br>_____ |
|         | M. Underbody box. Approx. 36-inches L x14-inches D x 16-inches W. One door. Frame mounted and welded to crossmembers. RKI model H361416 or equal.   | M<br>_____<br>_____<br>_____ |
|         | N. Underbody box. Approx. 36-inches L x18-inches D x 18-inches W. One door. Frame mounted and welded to crossmembers. RKI model H361818 or equal.   | N<br>_____<br>_____<br>_____ |
|         | O. Underbody box. Approx. 48-inches L x18-inches  | O<br>_____<br>_____<br>_____ |

|  |  |            |
|--|--|------------|
|  | D x 18-inches W. One door. Frame mounted and welded to crossmembers. RKI model H481818 or equal.   | _____      |
|  | P. Underbody box. Approx. 60-inches L x 18-inches D x 18-inches W. One door. Frame mounted and welded to crossmembers. RKI model H601818 or equal. | P<br>_____ |
|  | Q. Toolbox. Approx. 96-inches L x 18-inches D x 18-inches W. Two doors. Mounted on top of flatbed or stacked. RKI model H961818 or equal.          | Q<br>_____ |
|  | R. Over wheel well toolbox. Approx. 51-inches L x 13-3/16-inches D x 8-inches -13-11/16-inches W. RKI 50S or equal.                                | R<br>_____ |
|  | Window Grills and Racks.   |            |
|  | S. RKI model numbers.  | S<br>_____ |
|  | 1. Model WG-3 (For mid-size pickups. Ranger, Colorado, Tacoma)   | 1<br>_____ |
|  | 2. Model WG-10 (For full size wide pickups. F150, Silverado, 1500 Ram)   | 2<br>_____ |
|  | 3. Model WG-11 (For service body beds.   | 3<br>_____ |
|  | 4. Model RG-10 Bow type bracket (For 1/2 -ton trucks)  | 4<br>_____ |
|  | 5. Model RG-11 Bow type bracket (For Super Duty Trucks)  | 5<br>_____ |
|  | 6. Model LR049US Bow type tubular bracket (For Service body type beds)   | 6<br>_____ |

**Item 7: Fire Extinguisher**

| Item              | Specifications (Minimum)  | Bidder's Proposal                              |
|-------------------|---|--|
| Fire Extinguisher | Furnish and install a 2 ½ lb., size 1, type ABC, fire extinguisher in cab of vehicle. | Describe: _____<br>Make: _____<br>Model: _____ |

**Item 8: Safety Triangles**

| Item             | Specifications (Minimum)  | Bidder's Proposal                                       |
|------------------|---|---|
| Safety Triangles | Furnish a set of reflective safety triangles in cab of vehicle. Set to include three (3) reflective triangles in a carrying case. | Describe: _____<br>Make: _____<br>Model: _____<br>_____ |

**Item 9: Backup Alarm**

| Item                | Specifications (Minimum)  | Bidder's Proposal  |
|---------------------|---|--|
| <b>Backup Alarm</b> | Furnish and install a 97db backup alarm, PSE model D50H or equal on pickups, vans, SUV's, flatbed trucks, contractor bed trucks, dump body trucks, utility service bodies, etc. | Describe: _____<br>Make: _____<br>Model: _____<br>_____<br>_____ |

**Item 10: Electric Brake Controller**

| Item                             | Specifications (Minimum)   | Bidder's Proposal  |
|----------------------------------|--|--|
| <b>Electric Brake Controller</b> | Furnish and install an electric brake controller in cab of vehicle with a 6 way round pin (NOT RV SLOTTED) light connector at rear of vehicle. Vehicles will range from pickups to large trucks. Kelsey Model 81741B or equal. | Describe: _____<br>Make: _____<br>Model: _____<br>_____<br>_____ |

**Item 11: Trailer Light Connector 6 or 7 way**

| Item                           | Specifications (Minimum)  | Bidder's Proposal   |
|--------------------------------|---|---|
| <b>Trailer Light Connector</b> | Furnish and install a round pin, 6-way female light connector at the rear of the following vehicles. Each female connector socket installation shall also include a 6 to 7-way electrical adaptor, Velvac model 591010 or equal, enabling the vehicle to connect to either 6 or 7-way plugs.<br>Installation to include all material required to mount the female connector. On utility service bodies, contractor's beds, flatbeds, dump bodies, etc. Mount the electrical connector high enough and to the left of center so as not to be damaged by sharp turns by the trailer.<br>Velvac model BLO55052 or 7-way Velvac model #593083 or equal. | Describe: _____<br>Make: _____<br>Model: _____<br>_____<br>_____<br>_____<br>_____<br>_____<br>_____<br>_____<br>_____<br>_____ |
| <b>Options:</b>                | A. Cars.<br>B. Pickups.<br>C. Vans.<br>D. SUV's.<br>E. Utility Service Bodies.<br>F. Contractor's Beds.<br>G. Flatbeds.<br>H. Dump Bodies.<br>I. 6-Way to 7-way adaptor.  | Describe: _____<br>A _____<br>B _____<br>C _____<br>D _____<br>E _____<br>F _____<br>G _____<br>H _____<br>I _____              |

**Item 12: Hitch, Receiver type**

| Item                         | Specifications (Minimum)   | Bidder's Proposal  |
|------------------------------|--|--|
| <p><b>Receiver Hitch</b></p> | <p>Furnish and install a receiver type hitch with tongue and a two (2") inch (or 2 5/16" ball when specified). To include all materials and related items to mount the hitch.</p> <p>Include a 6-way female connector, round 6 pin truck application, Velvac model BL055052 or equal. Include a 6 to 7-way adaptor plug.</p> <p><b>The largest hitch allowed such as a 10,000 lb. hitch shall be installed whenever the GVW and vehicle type allows.</b></p>   | <p>Describe:</p> <p>Make: _____</p> <p>Model: _____</p> <p>_____</p> <p>_____</p> <p>_____</p> <p>_____</p> <p>_____</p> <p>_____</p> <p>_____</p> |
| <p><b>Options</b></p>        | <p>A. Cars, Class I, 2,000 lb.<br/>                     B. Vans, Class II, 3,500 lb.<br/>                     C. SUV's, Small Pickups, Class II, 3,500 lb.<br/>                     D. Pickups 6,000 GVW, Class III, 8,000 lb.<br/>                     E. Pickups 8,500 GVW, Class IV, 10,000 lb.<br/>                     F. Contractors Dump Beds, Class IV, 10,000 lb.<br/>                     G. Utility Service Bodies, Class IV, 10,000 lb.<br/>                     H. Flatbeds, Class IV, 10,000 lb.</p> | <p>Describe:</p> <p>A _____</p> <p>B _____</p> <p>C _____</p> <p>D _____</p> <p>E _____</p> <p>F _____</p> <p>G _____</p> <p>H _____</p>           |

**Item 13: Pintle Hitch Combination**

| Item                       | Specifications (Minimum)   | Bidder's Proposal   |
|----------------------------|--|---|
| <p><b>Pintle Hitch</b></p> | <p>Furnish and install a pintle hitch with a <b>2-inch or 2-5/16-inch ball as required</b>. Drop forged combination pintle hook/ball hitch. Kernis K300 or Buyers Model 16,000 lb. pintle hitch or acceptable equal. To be installed on Pickups, Vans, SUV's, Flatbed trucks, Contractor and Utility Service bodies, and rear of 5 yd Dump Trucks. (When mounting the pintle hitch to cars, pickups, SUVs, or vans, the <b>highest-class hitch</b> shall be installed as allowed by the GVW. If a lift gate is installed on flatbeds, service bodies, 5 CU yard dump bodies, or contractors' bodies a receiver hitch is required with an extended tongue to clear the bed when pulling trailers. The City may require a receiver hitch in certain circumstances on flatbeds, contractor bodies, utility service bodies. The receiver hitch shall be bid as specified below. If a receiver hitch is required to be mounted with a pintle hitch to flatbeds, contractor and utility service bodies, etc. seller shall include in the price any materials utilizing plate steel, etc. that must be fabricated for the frame mounting of the receiver hitch and pintle hitch. If mounting the pintle hitch to dump trucks, flatbed trucks, utility bodies, all materials required shall also be included in the Bid price. Include the price of any materials such as steel, bolts, etc. required to fully mount the pintle hitch.</p> | <p>Describe:</p> <p>Make: _____</p> <p>Model: _____</p> <p>_____</p> <p>_____</p> <p>_____</p> <p>_____</p> <p>_____</p> <p>_____</p> <p>_____</p> <p>_____</p> <p>_____</p> <p>_____</p> <p>_____</p> <p>_____</p> <p>_____</p> <p>_____</p> <p>_____</p> <p>_____</p> <p>_____</p> <p>_____</p> <p>_____</p> <p>_____</p> |



|                 |   |  |
|-----------------|---|--|
|                 | <p>Furnish and install a round pin, 6- way (Velvac model blo55052) or 7-way (Velvac model #593083 or equal) female light connector at rear of the vehicles. Each female connector socket installation shall also include a 6 to 7-way electrical adaptor (Velvac model 591010 or equal enabling the vehicle to connect to either 6-or 7-way plugs. Installation to include all materials required to mount the female connector.</p>  | <p>_____</p> <p>_____</p> <p>_____</p> <p>_____</p> <p>_____</p> <p>_____</p> <p>_____</p> <p>_____</p>  |
| <b>Options:</b> | <ul style="list-style-type: none"> <li>A. Pintle hitch &amp; tongue including an 8,000 lb. receiver hitch mounted on 6,000 lb. pickups.<br/>(A hitch may not be installed on the new Ford 6,000 GVW pickups if a lift gate is utilized due to mounting problems.)</li> <li>B. Pintle Hitch and Tongue including a 10,000 lb. receiver hitch mounted on 8,500 GVW Pickups.</li> <li>C. Pintle Hitch w/3,500 lb. Capacity Receiver Hitch w/Tongue &amp; Ball on SUV'S.</li> <li>D. Pintle Hitch and Tongue including a 3,500 lb. receiver hitch mounted on vans.</li> <li>E. Pintle Hitch w/a 10,000 lb. Receiver Installed on Flatbeds, Contractor Bodies, Utility Service Bodies. Include reinforcement material plus all mounting hardware.</li> <li>F. Pintle Hitch w/ a mounted on tongue only, NO HITCH.</li> </ul> | <p><u>Describe:</u></p> <p><b>A</b></p> <p>_____</p> <p>_____</p> <p>_____</p> <p>_____</p> <p>_____</p> <p><b>B</b></p> <p>_____</p> <p>_____</p> <p><b>C</b></p> <p>_____</p> <p>_____</p> <p><b>D</b></p> <p>_____</p> <p>_____</p> <p><b>E</b></p> <p>_____</p> <p>_____</p> <p><b>F</b></p> <p>_____</p> <p>_____</p> |

**Item 14: Pintle Hitch Holland-Model PH210 Air Actuated**

| <b>Item</b>             | <b>Specifications (Minimum)</b>  | <b>Bidder's Proposal</b>   |
|-------------------------|--|--|
| <b>Air Pintle Hitch</b> | <p>Furnish and install a Holland Model PH210 or acceptable equal air operated pintle hitch with a capacity of 90,000 lb. Gross Trailer Capacity and 18,000 lb. Vertical Load and include two Crosby 341, 1-inch weldless link trailer rings. To be installed on Flatbed trucks, Contractor and Utility Service bodies, and rear of Dump Trucks with air brakes. Include all materials required to mount or reinforce the hitch to dump trucks, flatbeds, utility bodies, etc.</p> <p>A 7-way electrical connector shall be provided and air supply with glad hands. Mount glad hands approx. 2-feet left and right of center in such a fashion that a trailer will not damage them in case of a sharp turn. The electrical connection shall be mounted up and left of center to avoid any damage from sharp turns. On dump trucks they must not hinder the dumping of materials.</p> | <p><u>Describe:</u></p> <p>_____</p> <p>_____</p> <p>_____</p> <p>_____</p> <p>_____</p> <p>_____</p> <p>_____</p> <p>_____</p> <p>_____</p> <p>_____</p> <p>_____</p> <p>_____</p> <p>_____</p> <p>_____</p> <p>_____</p> <p>_____</p> <p>_____</p> <p>_____</p> <p>_____</p> |



**Item 15: Lift Gates**

| Item                              | Specifications (Minimum)  | Bidder's Proposal   |
|-----------------------------------|---|---|
| <p><b>General Description</b></p> | <p>Lift gates shall be a Tommy gate, Theiman, Eagle Lift or Acceptable Equal.</p>   | <p><u>Describe:</u><br/> <u>Brand:</u><br/>                     _____<br/>                     _____</p>  |
| <p><b>Lift Gate</b></p>           | <p>Capacity: 1000, 1300, 1600 lb. To be installed on ½ &amp; ¾ ton pickups, compact pickups, one ton walk thru vans, delivery and cube vans, utility service bodies, contractor beds, and stake bodies. Standard loading platform. Shall not extend above pickup box when in the raised position.</p> <p>A. 150-amp heavy duty circuit breaker with manual trip switch furnished to protect electrical system.<br/>                     B. Control lever inside on the upright curbside corner.<br/>                     C. Audible safety alarm included.<br/>                     D. Chrome plated cylinder shaft.<br/>                     E. Hydraulics totally enclosed.<br/>                     F. Electric/hydraulic power unit to have a built-in relief valve.<br/>                     G. Inline flow control valve.<br/>                     H. Drop away platform.<br/>                     I. Liftgate housing to be 8-ga. Steel front and 10-ga. Steel rear.<br/>                     J. Upright housing to be 10-ga. steel.<br/>                     K. Reinforced single wall platform with torsion spring.<br/>                     L. Platform latches to be spring loaded &amp; quick release.<br/>                     M. 7/8 inch "D" hole pins with snap rings for arm pins.<br/>                     N. Upright pulleys to be 4-inches in diameter and housing pulleys to be<br/>                     O. 4½-inch diameter.<br/>                     P. Composite maintenance free bushings.<br/>                     Q. All retaining rings to be retained by snap rings.<br/>                     R. Gates to be primed and painted white to match the vehicle.<br/>                     S. Three (3) year Warranty on pump and motor and one (1) year on workmanship and all other parts.</p> | <p><u>Describe:</u><br/>                     _____<br/>                     _____<br/>                     _____<br/>                     _____<br/>                     _____<br/>                     _____<br/>                     A _____<br/>                     _____<br/>                     B _____<br/>                     C _____<br/>                     D _____<br/>                     E _____<br/>                     F _____<br/>                     _____<br/>                     G _____<br/>                     H _____<br/>                     I _____<br/>                     _____<br/>                     J _____<br/>                     K _____<br/>                     L _____<br/>                     _____<br/>                     M _____<br/>                     N _____<br/>                     O _____<br/>                     P _____<br/>                     Q _____<br/>                     R _____<br/>                     _____<br/>                     S _____<br/>                     _____<br/>                     _____</p> |
| <p><b>Options</b></p>             | <p>A. 1,000 lb. Liftgate for Compact and Mid-Size Pickups. Ranger, Colorado, Tacoma etc.</p> <p>B. 1,000 lb. Liftgate for standard ½ or ¾ ton pickups. <b>(NO Receiver Hitch may be used when a liftgate is ordered on new Ford F150 pickups. Both must be mounted to the end of frame.)</b></p> <p>C. 1,300 lb. Standard Type Liftgate for 1-ton walkthrough vans, panel vans, delivery and cube vans, utility service bodies.</p> <p>D. 1,300 lb. Dump through type Liftgate for 1-ton walkthrough vans, panel vans, delivery and cube vans, utility service bodies.</p>  | <p><u>Describe:</u><br/> <u>Make:</u><br/> <u>Model:</u><br/>                     A _____<br/>                     _____<br/> <u>Make:</u><br/> <u>Model:</u><br/>                     B _____<br/>                     _____<br/> <u>Make:</u><br/> <u>Model:</u><br/>                     C _____<br/>                     _____<br/> <u>Make:</u><br/> <u>Model:</u><br/>                     D _____<br/>                     _____<br/>                     _____</p>  |



|  |   |  |
|--|---|--|
|  | E. 1,300 lb. Standard Type Liftgate for stake bodies and contractor beds.   | Make: _____<br>Model: _____<br>E _____ |
|  | F. 1,300 lb. Dump Thru type Liftgate for stake bodies and contractor beds.  | Make: _____<br>Model: _____<br>F _____ |
|  | G. 1,600 lb. Standard type Liftgate for 1-ton walkthrough vans, panel vans, delivery and cube vans, utility service bodies.     | Make: _____<br>Model: _____<br>G _____ |
|  | H. 1,600 lb. Dump through type Liftgate for 1-ton walkthrough vans, panel vans, delivery and cube vans, utility service bodies. | Make: _____<br>Model: _____<br>H _____ |
|  | I. 1,600 lb. Standard type Liftgate for stake bodies and contractor dump beds.  | Make: _____<br>Model: _____<br>I _____ |
|  | J. 1,600 lb. Dump through type Liftgate for stake bodies and contractor dump beds.  | Make: _____<br>Model: _____<br>J _____ |

**Item 16: Light Bar Assembly, Non-Emergency, Low profile**

| Item                | Specifications (Minimum)  | Bidder's Proposal   |
|---------------------|---|---|
| General Description | <p>When specified Vehicles shall have one (1) Whelen 48-inch LED Liberty 11 WC series for Work vehicles and Security vehicles, Low Current Light bar or equal with Takedowns and Alley Lights, Six front and rear LED Flashers, LED Traffic Advisor directional light and Serial Communication operation control unit. Units to come with 20 ft of wiring.</p> <p><u>Installation</u></p> <p>The unit is to be wired through a relay to the battery and fused with an appropriate spade type in-line fuse sized to the unit being installed. There shall be a separate wire from the light bar to a chassis ground. The unit shall include a Whelen model PCCHDA or equal circuit breaker switch control center. Rocker switches are to be lighted, so the driver knows the light is on and mounted in the vehicle within arm's reach of the driver. Unit shall be mounted so that <b>no holes</b> are drilled into the top of the cab.</p> <p>Electrical wiring is not to be less than 12 gauge.<br/>                     Size: Approx. 2-1/2-inchesH x 48-inchesW x 12-inches D</p> | <p><u>Describe:</u></p> <p>_____</p> <p>_____</p> <p>_____</p> <p>_____</p> <p>_____</p> <p>_____</p> <p>_____</p> <p>_____</p> <p>_____</p> <p>_____</p> <p>_____</p> <p>_____</p> <p>_____</p> <p>_____</p> |

|                 |   |   |
|-----------------|---|---|
| <p>Options:</p> | <p>Lens: The light colors on the bar shall be two different configurations.</p> <p>16A. Work Vehicle Installed: Model IW8AAAA,<br/>Front: Red on the corners, Amber, Amber Clear, Clear, Amber &amp; Amber.<br/>Rear: Red on the corners, Blue, Amber, Blue, Blue, Amber &amp; Blue.</p> <p>16B. Work Vehicle <b>Not</b> Installed, walk out the door price: Model IW8AAAA:<br/>Front: Red on the corners, Amber, Amber Clear, Clear, Amber &amp; Amber.<br/>Rear: Red on the corners, Blue, Amber, Blue, Blue, Amber &amp; Blue.</p> <p>16C. Security Vehicle Installed: Model IW8RRRR Clear, Amber, Amber, Amber, Amber &amp; Clear.</p> <p>16D. Security Vehicle <b>Not</b> Installed, walk out the door price: Model IW8RRRR Clear, Amber, Amber, Amber, Amber &amp; Clear.</p> | <p><u>Describe:</u></p> <hr/> <hr/> <p>16A</p> <hr/> <hr/> <hr/> <hr/> <hr/> <p>16B</p> <hr/> <hr/> <hr/> <hr/> <hr/> <p>16C</p> <hr/> <hr/> <hr/> <hr/> <hr/> <p>16D</p> <hr/> <hr/> <hr/> <hr/> <hr/> |
|-----------------|---|---|

**Item 17: Non-Emergency 8 Light Traffic Advisor**

| Item                              | Specifications (Minimum)   | Bidder's Proposal  |
|-----------------------------------|--|--|
| <p><b>General Description</b></p> | <p>When specified Vehicles shall have one (1) Whelen model TA852L (or equal) low-profile Traffic Advisor directional light bar with eight (8) Amber colored LED lamp groups.<br/>Size: 1-7/16-inchesH x 2 9/16-inchesW x 43 7/8-inches L</p> <p><u>Installation</u></p> <p>A. The unit is to be wired through a relay to the battery and fused with an appropriate spade type in-line fuse sized to the unit being installed. There shall be a separate wire from the light bar to the chassis ground. The unit shall include a Whelen model TACTRL1A or equal control head. Control head to be a four (4) function rotary switch which selects from: left arrow, right arrow, split arrow, or flash pattern. A dip switch shall select a choice of 8 programmable flash patterns. Include a visual LED status display. Control head to be mounted within arms-reach of the driver. Unit shall be mounted so that <b>no holes</b> are drilled into the top of the cab.</p> <p>Electrical wiring is not to be less than 12 gauge.</p> <p>B. Light bar is to be rear facing, mounted at the top of a headache rack where applicable. When no headache rack is available, the unit is to be mounted on a tubular brace at the roof level of the vehicle or as appropriate to be clearly seen from the rear of the</p> | <p><u>Describe:</u></p> <p><u>Make:</u></p> <p><u>Model:</u></p> <hr/> <hr/> <hr/> <hr/> <hr/> <hr/> <hr/> <hr/> <hr/> <hr/> <p>A</p> <hr/> <hr/> <hr/> <hr/> <hr/> <hr/> <hr/> <hr/> <hr/> <hr/> <hr/> <p>B</p> <hr/> <hr/> <hr/> <hr/> <hr/> <hr/> <hr/> <hr/> <hr/> <hr/> |





**Item 19: Winch, 8,000 lb.**

| Item                       | Specifications (Minimum)  | Bidder's Proposal  |
|----------------------------|---|--|
| <b>General Description</b> | <p>Furnish and install a 12-volt front mounted, line pull of 8,000 lb. with 95 ft. (minimum) of 5/16-inch galvanized aircraft cable with replaceable clevis hooks. Warn, model M8, winch or equal.</p> <p>To be installed using Westin grill guard or equal on the following types of vehicles. Include all mounting materials and related items. F150 Model WES57-93835: F250 and up Model WES57-93095 or equal.</p> <p>Options:<br/>                     19A. Pickups 6,000 GVW to 9,500 GVW.<br/>                     19B. Heavy Duty Trucks from 9,600 GVW to 17,500 GVW.<br/>                     19C. Mounted in Bed of Heavy-Duty Trucks from 9,600 GVW to 17,500 GVW.</p> | <p>Describe:<br/>                     _____<br/>                     _____<br/>                     _____<br/>                     _____<br/>                     _____<br/>                     _____<br/>                     _____<br/>                     _____<br/>                     _____<br/>                     _____</p> <p>19A<br/>                     _____<br/>                     19B<br/>                     _____<br/>                     _____<br/>                     19C<br/>                     _____<br/>                     _____</p> |

**Item 20: Inverter**

| Item                                 | Specifications (Minimum)   | Bidder's Proposal   |
|--------------------------------------|--|---|
| <b>Equipment General Description</b> | <p>Current year model power inverter equal to a 2400-watt pure sine wave inverter, model DS 12/2400N manufactured by Sensata. <a href="http://www.Sensata.com">www.Sensata.com</a></p>   | <p>Describe:<br/>                     _____<br/>                     _____<br/>                     _____</p>   |
| <b>Inverter</b>                      | <ol style="list-style-type: none"> <li>1. Ability to convert 12-volt dc to 110/120 vac 60 Hz AC voltage and provide up to 21-amps of 110-volt AC power.</li> <li>2. 2400-watts continuous power and 5000-watts surge capacity (peak power).</li> <li>3. High surge capability to start heavy loads such as lamps, motors, &amp; other inductive loads.</li> <li>4. Internal high-speed cooling fan.</li> <li>5. High voltage protection.</li> <li>6. Low voltage protection.</li> <li>7. Overload protection.</li> <li>8. Low battery alarm.</li> <li>9. Low battery shutdown.</li> <li>10. Short circuit protection.</li> <li>11. To have a smooth start-up of tools and appliances.</li> <li>12. Noise free technology to prevent buzz, snow &amp; static lines.</li> <li>13. Approximately 90% efficiency.</li> </ol> | <p>Describe:<br/>                     1 _____<br/>                     _____<br/>                     _____<br/>                     2 _____<br/>                     _____<br/>                     _____<br/>                     3 _____<br/>                     _____<br/>                     _____<br/>                     4 _____<br/>                     _____<br/>                     _____<br/>                     5 _____<br/>                     _____<br/>                     _____<br/>                     6 _____<br/>                     _____<br/>                     _____<br/>                     7 _____<br/>                     _____<br/>                     _____<br/>                     8 _____<br/>                     _____<br/>                     _____<br/>                     9 _____<br/>                     _____<br/>                     _____<br/>                     10 _____<br/>                     _____<br/>                     _____<br/>                     11 _____<br/>                     _____<br/>                     _____<br/>                     12 _____<br/>                     _____<br/>                     _____<br/>                     13 _____<br/>                     _____<br/>                     _____</p> |
| <b>Warranty</b>                      | <p>2-year warranty.</p>  | <p>Describe:<br/>                     _____<br/>                     _____</p>  |

|                          |   |   |
|--------------------------|---|---|
| <b>Manuals</b>           | Provide one set of operations manuals.  | <u>Describe:</u><br>_____   |
| <b>Optional Mounting</b> | <p><u>Option 1:</u><br/> <u>Service bodies:</u><br/>                     The inverter shall be mounted inside the right front cabinet of a utility service body on the floor utilizing at least a 2-inch riser to keep the inverter off the floor in case of water accumulation. The unit needs to be mounted so not to obstruct the use of the cabinet. The unit shall be equipped with a 120-vac weatherproof duplex outlet mounted inside the same cabinet area as high in the cabinet as possible so as not to obstruct the cabinet area. All materials required to make the unit operational shall be provided by Bidder.</p> <p>An additional battery to power the inverter is to be mounted in a battery box in the bed of the utility body next to the right front cabinet with power cables running through the box to the inverter inside the cabinet. The access holes for the power cables are to be sealed from the weather and moisture. This battery is to be charged from the engine alternator, but on an isolated circuit so as not to drain cranking battery on the truck.</p> <p><b><u>Ford trucks should have a high idle speed up switch and computer installed by Ford for inverter use.</u></b></p> <p><u>Option 2:</u><br/> <u>Pickups and cab &amp; chassis:</u><br/>                     When mounting inside the cab such as an extended cab, the converter shall be mounted the seat on the floor out of the way as much as possible and if no foot room is left-a protective cover of shall be utilized to protect the converter from feet being placed on the converter.</p> <p><b><u>Ford trucks should have a high idle speed up switch and computer installed by Ford for inverter use.</u></b></p> | <p><u>Describe:</u><br/>                     1<br/>                     _____<br/>                     _____<br/>                     _____<br/>                     _____<br/>                     _____<br/>                     _____<br/>                     _____<br/>                     _____<br/>                     _____<br/>                     _____<br/>                     _____<br/>                     _____<br/>                     _____<br/>                     _____<br/>                     _____<br/>                     _____<br/>                     _____<br/>                     _____</p> <p>2<br/>                     _____<br/>                     _____<br/>                     _____<br/>                     _____<br/>                     _____<br/>                     _____<br/>                     _____<br/>                     _____<br/>                     _____<br/>                     _____</p> |

**Item 21: Chains Trailer Safety**

| Item   | Specifications (Minimum)   | Bidder's Proposal  |
|--|--|--|
| Trailer Safety Chains, And Hooks for Trailers; Links for Trucks: | <p><b><u>Hook Detail</u></b><br/>                     All hooks will be Crosby Grade 8 Alloy Steel Latching Clevis Hooks, (heat treated), which meets the new NACM and proposed ASTM and Euro norm Standards for Grade 8 Chain fittings. The hooks are anti-fouling due to carefully designed contours and are individually tested at 2 1/2 times the working load limit, with certification packed with each hook. These hooks are also fatigue rated. (Domestic Only, Crosby or Equal and Certificate of Compliance Required).</p> | <p><u>Describe:</u><br/>                     _____<br/>                     _____<br/>                     _____<br/>                     _____<br/>                     _____<br/>                     _____<br/>                     _____<br/>                     _____<br/>                     _____</p> |





|  |  |   |
|--|--|---|
|  | <p>Sling links for attaching trailer safety chains to rear of truck shall be sizes to GCWR of hitch:</p> <p>D. Class I, II, &amp; III (not to exceed 5,000 lb.) Qty (2) S341 1/2-inch weldless sling links. Working Load Limit=2,900 lb. – UL=17,400 lb.</p> <p>E. Class IV (not to exceed 10,000 lb.) Qty (2) S341 3/4-inch weldless sling links. Working Load Limit=6,000 lb. – UL=36,000 lb.</p> <p>F. Class V (not to exceed 30,000 lb.) Qty (2) S341 1-inch weldless sling link Working Load Limit=10,800 lb. – UL=64,800 lb.</p> | <p><u>D</u></p> <hr/> <hr/> <p><u>E</u></p> <hr/> <hr/> <p><u>F</u></p> <hr/> <hr/> |
|--|--|---|

**CITY OF TULSA STANDARD NO. 000085** Appendix 701-A

**Trailer Safety Chain Specifications by Part**

**Hook Detail**  
All hooks will be Crosby Grade 8 Alloy Steel Latching Clevis Hooks, (heat treated), which meets the new NACM and proposed ASTM and Euronorm Standards for Grade 8 Chain fittings. The hooks are anti-fouling due to carefully designed contours and are individually Proof Tested at 2 1/2 times the Working Load Limit, with certification, packed with each hook. These hooks are also fatigue rated. The Ultimate Load is 4 times the Working Load Limit. Crosby Part #S314A. (Domestic Only, Crosby or Equal and Certificate of Compliance Required).

**Chain Detail**  
All Chain will be equal to Crosby Spectrum 8 Alloy Chain. Proof loaded a 2 1/2 times Working Load Limit, and a minimum Ultimate Load of 4 times the Working Load Limit. Purchasing information, (Domestic Only, Crosby or Equal and Certificate of Compliance Required).

**Connecting Link Detail**  
Crosby Lok-A-Loy Alloy Connecting Link, Quenched and Tempered are individually Proof Tested Forged Alloy Steel. The Ultimate Load is 4 times the Working Load Limit. Purchasing information, (Domestic Only, Crosby or Equal and Certificate of Compliance Required).

**Weldless Sling Links**  
Crosby Forged Carbon Steel, Quenched and Tempered. The Ultimate Load is 6 times the Working Load Limit. These links must be equal to the Crosby S341. Purchasing information (Domestic Only, Crosby or Equal and Certificate of Compliance Required).

**Containment Unit for Weldless Links**  
The steel strips which will be made in accordance with Attachment "T" will contain the Weldless Sling Links to the trailer and pulling vehicle.

**Weldless Link Holding Device**

The weldless link is 1 inch in diameter. A steel strip will be heated and formed over a 1-1/4 inch round bar. The steel strip will then be placed over weldless link and welded on all three sides up to where the steel strip fits over weldless link. The weld strength should be a minimum of 60,000 pounds per square inch. The steel strip dimensions will be : 3/8 inch thick, 8 inches long and 2-1/2 inches wide and should be Grade: A36 material.

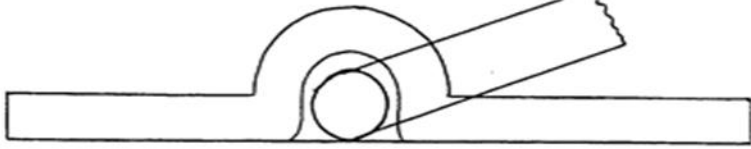

170

**Item 22: Conspicuity Tape**

| Item           | Specifications (Minimum)   | Bidder's Proposal                     |
|----------------|--|---------------------------------------|
| <b>General</b> | Install Conspicuity tape on the rear of all vehicles that do not have bodies installed. 12-foot minimum of tape. | <u>Describe:</u><br><hr/> <hr/> <hr/> |

**Item 23: Stake Bodies**

| Item                              | Specifications (Minimum)   | Bidder's Proposal   |
|-----------------------------------|--|---|
| <b>General Description</b>        | This Specification shall provide for steel stake bodies, new, the latest current production mode. Complete with manufacturer's standard equipment and accessories, fully serviced ready to operate. To include manufacturer's certificate or warranty and be bid less all applicable State and Federal Taxes. (Warranty shall be the standard for the industry as offered to the public.) This body shall be equipped to meet all Federal and State of Oklahoma Safety Standards and Requirements. No dealer advertisement shall be affixed to the bed. Conspicuity Reflective tape shall be applied to rear of all bodies for safety. | <u>Describe:</u><br><hr/> <hr/> <hr/> <hr/> <hr/> <hr/> <hr/> <hr/> <hr/> |
| <b>Type:</b>                      | Heavy-Duty quality   | <u>Describe:</u><br><hr/>   |
| <b>Mainsills</b>                  | Structural channel Mainsills as follows:<br>1. 8-feet 6-inches to 9-feet 6-inches Bodies to have minimum 4-inches<br>2. 10-feet 6-inches to 14-feet 6-inches Bodies to have minimum 6-inches<br>3. 15-feet 6-inches to 20-feet 6-inches Bodies to have minimum 7-inches<br>4. 22-feet 6-inches to 24-feet 6-inches Bodies to have minimum 8-inches   | <u>Describe:</u><br>1 <hr/><br>2 <hr/><br>3 <hr/><br>4 <hr/><br><hr/>     |
| <b>Crossmembers</b>               | 11-gauge formed crossmembers on approximately 12-inch centers on stake bodies 14-feet. or longer, and 16-inch centers for bodies shorter than 14-feet.   | <u>Describe:</u><br><hr/> <hr/> <hr/>                                     |
| <b>End Rails &amp; Side Rails</b> | 11-gauge steel thickness x approx. 6-inches equipped with 2X4 stake pockets reinforced. Welded and smoothed 45 deg corners   | <u>Describe:</u><br><hr/> <hr/> <hr/>                                     |
| <b>Floor</b>                      | 3/16-inch Thick, Steel Treadplate  | <u>Describe:</u><br><hr/>   |

|                              |   |   |
|------------------------------|---|---|
| <b>Lights and Reflectors</b> | Dual Wheel, Standard lighting, recessed and in accordance with all State of Oklahoma and Federal laws governing highway safety. Install Conspicuity tape on the rear of the bed. 12-feet minimum. | <u>Describe:</u><br>_____<br>_____<br>_____ |
| <b>Warranty</b>              | Platforms, bulkheads and side assemblies will be covered by a minimum of 12 months manufacturer's warranty.   | <u>Describe:</u><br>_____<br>_____          |

**MOUNTING INSTRUCTIONS:** Mounting shall be consistent with normal practice for bodies of this type.

**NOTE:** Seller must NOT remove identification plates or numbers on the truck. This especially applies to the truck transmission when power takeoff is installed. If, during installations, it becomes necessary to remove these plates or cover these numbers, then these numbers and/or plates must be replaced in a visible location.

**ELECTRICAL WIRING:** Wiring is to be in loom and properly secured to frame to prevent sagging. Upon completion of installation, all connections, splices, and wiring shall be protected by all-weather insulation. This insulation material to be of sufficient quality to insure a life period of five (5) years.

**POWER TAKE-OFF:** (If required) must be the latest current model installed and/or adapted to fit the transmission. Mounting bolts or screws must provide adequate self-locking and sealing to insure against oil leaks and must keep housing firmly attached to transmission.

**PAINT:** All exposed metal shall be primed and painted. The bed shall be sprayed or dipped with a protective metal primer, then be painted Factory White to match vehicle.

**NOTE:** Bed Widths to be minimum 94" wide

**SIZES:**

**Bidders Fill out sections in Yellow**

| Item | Approx. Length | Approx. Cab to Axle | Bidder's Proposal            |               |
|------|----------------|---------------------|------------------------------|---------------|
| A    | 8'6"           | 56"                 | <u>Actual Length:</u>        | <u>Make:</u>  |
|      |                |                     | <u>Cab to Axle Required:</u> | <u>Model:</u> |
| B    | 9'6"           | 60"                 | <u>Actual Length:</u>        | <u>Make:</u>  |
|      |                |                     | <u>Cab to Axle Required:</u> | <u>Model:</u> |
| C    | 10'6"          | 84"                 | <u>Actual Length:</u>        | <u>Make:</u>  |
|      |                |                     | <u>Cab to Axle Required:</u> | <u>Model:</u> |
| D    | 12'6"          | 84"                 | <u>Actual Length:</u>        | <u>Make:</u>  |
|      |                |                     | <u>Cab to Axle Required:</u> | <u>Model:</u> |
| E    | 14'6"          | 108"                | <u>Actual Length:</u>        | <u>Make:</u>  |
|      |                |                     | <u>Cab to Axle Required:</u> | <u>Model:</u> |
| F    | 16'6"          | 120"                | <u>Actual Length:</u>        | <u>Make:</u>  |



|   |       |      |                              |               |
|---|-------|------|------------------------------|---------------|
|   |       |      | <b>Cab to Axle Required:</b> | <b>Model:</b> |
| G | 18'6" | 120" | <b>Actual Length:</b>        | <b>Make:</b>  |
|   |       |      | <b>Cab to Axle Required:</b> | <b>Model:</b> |
| H | 20'6" | 150" | <b>Actual Length:</b>        | <b>Make:</b>  |
|   |       |      | <b>Cab to Axle Required:</b> | <b>Model:</b> |
| I | 22'6" | 150" | <b>Actual Length:</b>        | <b>Make:</b>  |
|   |       |      | <b>Cab to Axle Required:</b> | <b>Model:</b> |
| J | 24'6" | 165" | <b>Actual Length:</b>        | <b>Make:</b>  |
|   |       |      | <b>Cab to Axle Required:</b> | <b>Model:</b> |

|                 |   |                             |
|-----------------|---|-----------------------------|
| <b>Options:</b> | 1. Stakes 14-Gauge roll formed Steel contractor sides, Approx. 14-inches high, Removable  | <b>Describe:</b><br>1 _____ |
|                 | 2. Stakes 14-Gauge roll formed Steel city stake sides, Approx. 40-inches high, Removable  | 2 _____                     |
|                 | 3. Floor Wood, 2-inch Nominal Tongue & Groove Southern Pine, Pressure treated   | 3 _____                     |
|                 | 4. Floor; 1-3/8-inch Apitong Wood Floor   | 4 _____                     |
|                 | 5. Floor: 3/16-inch Thick, Smooth Steel   | 5 _____                     |
|                 | 6. Bulkhead: 12-Gauge Steel, reinforced with full visibility window, and side wings. (Expanded metal window protection)   | 6 _____                     |
|                 | 7. Tail Roller 4" Dia. x 49" Long mounted on roller bearings  | 7 _____                     |
|                 | 8. Solid Tail Pipe – solid tail pipe on bed 4" Dia. x approx. 49" Long. Pipe with no bearings to form a rounded surface for items to slide over edge of bed. Solid mount. | 8 _____                     |
|                 | 9. Lift Gate, Hydraulic, 1300 lb. capacity.   | 9 _____                     |
|                 | 10. Ratchet Straps: Quantity of five (5), (Evenly spaced) welded to the bottom side of the bed. Straps to be 4-inches wide and 30-feet long, with J hook on one end.      | 10 _____                    |
|                 | 11. Reinforcement for Electric Hoist curbside rear up to 3200 lb. Crane. (Shall include spring reinforcement if necessary to correct any side tilt of body)               | 11 _____                    |
|                 | 12. Reinforcement for hydraulic Hoist curbside rear up to 5,000 LB Crane (Shall include spring reinforcement if necessary to correct any side tilt of body).              | 12 _____                    |



|                                      |   |  |
|--------------------------------------|---|--|
|                                      | <p>to prevent overloading. In-line flow control valve-controls the speed of the oil.</p> <p>F. Drop-away platform.</p> <p>G. Liftgate housing: 8-ga. Steel front, 10-ga. Steel rear. Upright housing: 10-ga. Steel upright.</p> <p>H. Reinforced single-wall platform with torsion spring: 12-ga. Smooth steel load skin. Outer platform edge protection tube 7/8-inch dia. "D" hole pins with snap rings for arm pins.</p> <p>I. Liftgate cable: 5/16-inch dia. 6-inch x 36-inch stranded cable.</p> <p>J. Dump-thru tailgate release handle: single lever dump-thru tailgate release mechanism located on driver's side of truck.</p> | <p>_____</p> <p>_____</p> <p>F</p> <p>G</p> <p>_____</p> <p>H</p> <p>_____</p> <p>_____</p> <p>I</p> <p>_____</p> <p>J</p> <p>_____</p> <p>_____</p> |
| <p><b>Hoist</b></p>                  | <p>NTEA Class B Hoist with standard double acting cylinder</p> <p>A. Cylinder bore: 4-inch</p> <p>B. Cylinder stroke: 15¼-inch</p> <p>C. Cylinder shaft is chromed SW85 steel, 85,000 PSI yield strength</p> <p>D. Maximum operating pressure: 3250 PSI</p> <p>E. 50 degree dumping available</p> <p>F. 9-inch mounting height</p> <p>G. 4-GPM direct mount gear pump, open center valve mounted to a 15-quart capacity reservoir, self-centering locking sealed cable control with pedestal stand.</p>   | <p>Describe:</p> <p>_____</p> <p>A</p> <p>B</p> <p>C</p> <p>_____</p> <p>D</p> <p>E</p> <p>F</p> <p>G</p> <p>_____</p> <p>_____</p>                  |
| <p><b>Mounting Instructions:</b></p> | <p>Mounting shall be consistent with normal practice for bodies of this type.</p>   | <p>Describe:</p> <p>_____</p> <p>_____</p>   |
| <p><b>Warranty</b></p>               | <p>The body will be covered by a minimum of 12-month manufacturer's warranty.</p> <p>Bidder shall provide a manufacturer's written 5-year warranty covering repair or replacement of the hoist and air cylinder for defective material and/or workmanship.</p>  | <p>Describe:</p> <p>_____</p> <p>_____</p> <p>_____</p> <p>_____</p>   |

**NOTE:** Seller must NOT remove identification plates or numbers on the truck. This especially applies to the truck transmission when power take-off is installed. If, during installations, it becomes necessary to remove these plates or cover these numbers, then these numbers and/or plates must be replaced in a visible location.

**ELECTRICAL WIRING:** Wiring to be in loom and properly secured to frame to prevent sagging. Upon completion of installation all connections, splices and wiring to be protected by all-weather insulation. This insulation material to be of sufficient quality to insure a life period of five (5) years.

**POWER TAKE-OFF:** (If required) must be the latest current model installed and/or adopted to fit the transmission. Mounting bolts or screws must provide adequate self-locking and sealing to insure against oil leaks and must keep housing firmly attached to transmission.

**PAINT:** All exposed metal shall be primed and painted. The bed shall be sprayed or dipped with a protective metal primer, then be painted Factory White to match vehicles.

**Bidders fill out sections in Yellow**

| Item | Approx. Length | Approx. Cab to Axle | Bidder's Description                                |                             |
|------|----------------|---------------------|---|-----------------------------|
| A    | 8'6"           | 56"                 | Actual Length: _____<br>Cab to Axle Required: _____ | Make: _____<br>Model: _____ |
| B    | 9'6"           | 60"                 | Actual Length: _____<br>Cab to Axle Required: _____ | Make: _____<br>Model: _____ |
| C    | 10'6"          | 84"                 | Actual Length: _____<br>Cab to Axle Required: _____ | Make: _____<br>Model: _____ |
| D    | 12'6"          | 84"                 | Actual Length: _____<br>Cab to Axle Required: _____ | Make: _____<br>Model: _____ |
| E    | 14'6"          | 108"                | Actual Length: _____<br>Cab to Axle Required: _____ | Make: _____<br>Model: _____ |
| F    | 16'6"          | 120"                | Actual Length: _____<br>Cab to Axle Required: _____ | Make: _____<br>Model: _____ |

|                |  |   |
|----------------|--|---|
| <b>Options</b> | <ol style="list-style-type: none"> <li>1. Floor: 3/16-inch Thick Steel, Treadplate</li> <li>2. Floor: 3/16-inch Thick Steel, Smooth</li> <li>3. Contractors Sides: 14-inch-high x 14-gauge solid steel sides with tailgate, removeable.</li> </ol> | Describe:<br>1 _____<br>2 _____<br>3 _____<br>_____ |
|----------------|--|---|

**Item 25: Service Body, Utility Type**

| Item           | Specifications (Minimum)   | Bidder's Proposal  |
|----------------|--|--|
| <b>General</b> | This Specification shall provide new steel utility service body, the latest current production model. Complete with manufacturer's standard equipment and accessories, fully serviced ready to operate. To include manufacturer's certificate of warranty. (Warranty shall be the standard for the industry as offered to the public.) This body shall be equipped to meet all Federal and State of Oklahoma Safety Standards and Requirements. No dealer advertisement shall be affixed to the body. Conspicuity Reflective tape shall be applied to rear of all bodies for safety. | Describe:<br>_____<br>_____<br>_____<br>_____<br>_____<br>_____<br>_____<br>_____<br>_____ |
| <b>Type</b>    | Heavy duty utility service body installed.<br>Note: All Body parts are to be electrically welded into one integral unit  | Describe:<br>_____<br>_____<br>_____   |

|                                     |  |  |
|-------------------------------------|--|--|
| <p><b>Understructure</b></p>        | <ol style="list-style-type: none"> <li>1. 7-gauge minimum, high strength steel formed cross members front and rear of body.</li> <li>2. 7-gauge minimum, high strength steel formed intermediate cross members.</li> <li>3. 4 full-length 14-gauge formed "hat" channel longitudinal for full-length floor support.</li> </ol>   | <p><u>Describe:</u></p> <p>1 _____</p> <p>2 _____</p> <p>3 _____</p>   |
| <p><b>Floor</b></p>                 | <p>12-gauge tread plate floor.</p>   | <p><u>Describe:</u></p> <p>_____</p>   |
| <p><b>Doors</b></p>                 | <ol style="list-style-type: none"> <li>1. Double panel doors with 20-gauge galvanized outer panel and 20-gauge galvanized inner panel.</li> <li>2. Stainless steel rod door pins</li> <li>3. Stainless steel pillow blocks with self-lubricating bushings (3) per door.</li> <li>4. Stainless steel paddle latches, lockable.</li> <li>5. Heavy-duty chain or cable supports on horizontal doors.</li> <li>6. Gas shocks door retainers on vertical doors.</li> <li>7. Automotive neoprene door seal.</li> </ol>   | <p><u>Describe:</u></p> <p>1 _____</p> <p>2 _____</p> <p>3 _____</p> <p>4 _____</p> <p>5 _____</p> <p>6 _____</p> <p>7 _____</p>   |
| <p><b>Body</b></p>                  | <ol style="list-style-type: none"> <li>1. Full 14-gauge galvanized construction.</li> <li>2. Seamless fender panel.</li> <li>3. 4 front 16-gauge galvanized shelving is adjustable on 2-foot centers.</li> <li>4. Shelving is slotted for adjustable dividers on 2-inch centers.</li> <li>5. Approx. 20 adjustable dividers for compartment shelving.</li> <li>6. 2 rear 16-gauge Galvanized shelves adjustable on 4-inch centers.</li> <li>7. Nylon coated stainless steel cables to support tailgate.</li> <li>8. Body fully undercoated per OSHA and NFPA specifications.</li> <li>9. 5-year manufacturer's standard warranty. Does not apply to normal wear and tear.</li> <li>10. 12-gauge A40 galvanized step type rear bumper with treadplate surface. Full step recessed for a pintle hitch or ball hitch plate safety type bumper. Bumper to include reinforcement for a 5,000 lb. trailer capacity.</li> </ol> | <p><u>Describe:</u></p> <p>1 _____</p> <p>2 _____</p> <p>3 _____</p> <p>4 _____</p> <p>5 _____</p> <p>6 _____</p> <p>7 _____</p> <p>8 _____</p> <p>9 _____</p> <p>10 _____</p> |
| <p><b>Compartments</b></p>          | <p>Four (4) to six (6) Compartments per side approx. 15-inch deep on 8,600 GVW and 20-inch Deep on 108-inch body, Eight (8) compartments on 132-inch body with long horizontal compartment over wheelhouse and rear compartment on both street side and curb side.</p>   | <p><u>Describe:</u></p> <p>_____</p> <p>_____</p> <p>_____</p> <p>_____</p>  |
| <p><b>Lights and Reflectors</b></p> | <p>Standard lighting recessed and in accordance with all State of Oklahoma and Federal laws governing highway safety. Install Conspicuity tape on the rear of the bed. 12-feet minimum.</p>  | <p><u>Describe:</u></p> <p>_____</p> <p>_____</p> <p>_____</p>   |

|                              |   |   |
|------------------------------|---|---|
| <b>Mounting Instructions</b> | <p>Mounting shall be consistent with normal practice for bodies of this type.</p> <p>NOTE: Seller must NOT remove identification plates or numbers from the truck. This especially applies to truck transmission when power take off is installed. If, during installation, it becomes necessary to remove these plates or cover these numbers, then these numbers and/or plates must be replaced in a visible location.</p> <p>ELECTRICAL WIRING AND LIGHTS: Wiring to be in loom and properly secured to frame to prevent sagging. Upon completion of installation all connections, splices and wiring to be protected by all-weather installation. This installation material to be of enough quality to insure a life period of five (5) years. Lights shall be DOT approved for the state of Oklahoma.</p> | <p><u>Describe:</u></p> <hr/> <hr/> <hr/> <hr/> <hr/> <hr/> <hr/> <hr/> <hr/> <hr/> <hr/> <hr/> <hr/> <hr/> <hr/> <hr/> <hr/> <hr/> <hr/> <hr/> <hr/> <hr/> <hr/> <hr/> |
|------------------------------|---|---|

**Bidder to fill out the portion in Yellow below.**

| Dimensions |  |                        |                     |                           |                              |
|------------|--|------------------------|---------------------|---------------------------|------------------------------|
|            | Model Length Requested   | Approx. Overall Height | Approx. Cab to Axle | Chassis Size              | Wheel Well Type              |
| A.         | 96" "H" Model (See Notes)  | 40"                    | 56"                 | 8,500 GVW                 | Single                       |
| <b>A.</b>  | Bidder Fill Out This Row:<br>Bidders Make: _____<br>Bidders Model: _____ | Actual HT. _____       | Actual CA _____     | Actual Chassis Size _____ | Actual Wheel well Type _____ |
| B.         | 96" "V" Model (See Notes)  | 40"                    | 56"                 | 8,500 GVW                 | Single                       |
| <b>B.</b>  | Bidder Fill Out This Row:<br>Bidders Make: _____<br>Bidders Model: _____ | Actual HT. _____       | Actual CA _____     | Actual Chassis Size _____ | Actual Wheel well Type _____ |
| C.         | 96" "LowProfile" Model (See Notes)                                       | 36"                    | 56"                 | 8,500 GVW                 | Single                       |
| <b>C.</b>  | Bidder Fill Out This Row:<br>Bidders Make: _____<br>Bidders Model: _____ | Actual HT. _____       | Actual CA _____     | Actual Chassis Size _____ | Actual Wheel well Type _____ |
| D.         | 108" Model   | 44"                    | 60"                 | 10,000 GVW                | Dual                         |
| <b>D.</b>  | Bidder Fill Out This Row:<br>Bidders Make: _____<br>Bidders Model: _____ | Actual HT. _____       | Actual CA _____     | Actual Chassis Size _____ | Actual Wheel well Type _____ |
| E1.        | 108" "Low Profile" Model (See Notes)                                     | 36"                    | 60"                 | 10,000 GVW                | Single Available             |
| <b>E2.</b> | 108" "Low Profile" Model (See Notes)                                     | 36"                    | 60"                 | 10,000 GVW                | Dual Available               |
| <b>E1.</b> | Bidder Fill Out This Row:<br>Bidders Make: _____<br>Bidders Model: _____ | Actual HT. _____       | Actual CA _____     | Actual Chassis Size _____ | Actual Wheel well Type _____ |



|     |  |                     |                    |                              |                                 |
|-----|--|---------------------|--------------------|------------------------------|---------------------------------|
| E2. | Bidder Fill Out This Row:<br>Bidders Make: _____<br>Bidders Model: _____ | Actual HT.<br>_____ | Actual CA<br>_____ | Actual Chassis Size<br>_____ | Actual Wheel well Type<br>_____ |
| F.  | 132" Model   | 44"                 | 84"                | 10,000 GVW                   | Dual                            |
| F.  | Bidder Fill Out This Row:<br>Bidders Make: _____<br>Bidders Model: _____ | Actual HT.<br>_____ | Actual CA<br>_____ | Actual Chassis Size<br>_____ | Actual Wheel well Type<br>_____ |

**NOTE:** Models with "H" designation to have Full height vertical compartments front and rear with a horizontal center compartment over wheel well.

Models with a "V" designation to have full height compartments front with a center horizontal compartment extending to the rear of body and an 18" vertical compartment rear.

| OPTIONS  | Describe:   |
|--|---|
| 1. <u>Master Lock System</u> , capability to lock all service body doors on one (1) side with one location.  | 1 _____   |
| 2. <u>Bumper w/liftgate cutouts</u> When a liftgate is installed, the bumper shall be notched out to allow the lift gate arms to operate through the bumper. The edges of notched portion shall be ground smooth and dressed so no sharp edges or metal is protruding.   | 2 _____   |
| 3. <u>Top-Pak</u> Integral top opening lid each side. All Galvannealed Steel, Weather-Proof Seal and Adjustable Storage dividers. Compartment runs full length of body, 4" deep.   | 3 _____   |
| 4. <u>High Roof:</u> With Heights from Floor to Roof 54-inch, 60-inch or 72-inch with (2) 4-inch diameter gravity air vents, waterproof. All panel assemblies.<br>4A. 108-inch body with 54-inch-high roof.<br>4B. 108-inch body with 60-inch-high roof.<br>4C. 108-inch body with 72-inch-high roof.<br>4D. 132-inch body with 54-inch-high roof.<br>4E. 132-inch body with 60-inch-high roof.<br>4F. 132-inch body with 72-inch-high roof.<br>4G. Roll up rear door with high roof.<br>4H. Pair of conduit doors, one (1) on each side with high roof.<br>4I. Overhead mounted Ladder Rack.<br>4J. Side mounted Ladder Rack. | 4 _____<br>4A _____<br>4B _____<br>4C _____<br>4D _____<br>4E _____<br>4F _____<br>4G _____<br>4H _____<br>4I _____<br>4J _____ |
| 5. <u>Crane Base</u> Right rear curbside corner reinforcement for 108-inch and 132-inch-long bodies only, up to a 3,200 lb. crane, 16,000 ft. lb. capacity.<br><u>Include any spring reinforcing to correct any body tilt.</u>   | 5 _____   |
| 6. <u>Additional Shelving for 108-inch Body Dividers and shelving shall be 18-gauge G60 minimum spangle galvanized steel, slotted on 2-inch centers for dividers, removable, lock in place and include the following:</u><br>1 set (4/set) 17-inch-deep divided trays for front vertical cabinet (2 ea. side).<br>1 set (4/set) 17-inch-deep trays, 2 <sup>nd</sup> vertical cabinet from cab, driver's side.  | 6 _____   |







Picture depicts drawer configuration vs extra shelving pkg.

**Item 26: Crane Body 38,000 Ft/lb.**

| Item            | Specifications (Minimum)  | Bidder's Proposal   |
|-----------------|---|---|
| <b>General</b>  | This Specification shall provide for new 38K series crane body, the latest current production model. Complete with manufacturer's standard equipment and accessories, fully serviced ready to operate. To include manufacturer's certificate or warranty. (Warranty shall be the standard for the industry as offered to the public.) This body shall be equipped to meet all Federal and State of Oklahoma Safety Standards and Requirements. No dealer advertisement shall be affixed to the body. Conspicuity Reflective tape shall be applied to rear of all bodies for safety. | Describe:<br>_____<br>_____<br>_____<br>_____<br>_____<br>_____<br>_____<br>_____ |
| <b>Model</b>    | Auto Crane or equivalent. 84 Inch CA, 38,000 ft. lbs. Series Crane Body or acceptable equal, installed on 11,000 GVW TO 27,500 GVW Trucks (City of Tulsa will supply the cab and chassis). <u>The truck will very likely require a 90" Cab to Axle to allow room for the exhaust bracket if mounted on International trucks.</u>  | Describe:<br>_____<br>_____<br>_____<br>_____<br>_____                            |
| <b>Capacity</b> | Capable of handling up to 38,000 ft-lb. of crane moment load in all positions of rotation. Be stable with full-load crane with rear outriggers fully deployed when mounted on adequate chassis as specified NO front corner outriggers are required for stability.<br><u>CRANE IS NOT INCLUDED IN SPECIFICATION.</u>  | Describe:<br>_____<br>_____<br>_____<br>_____<br>_____                            |



|                              |  |   |
|------------------------------|--|---|
|                              | <p>10-ga. A40 galvanized steel inner panel.<br/>                 Paddle latch – chrome plated.<br/>                 Internal latching mechanism is zinc plated.<br/>                 Bottom vent for bottled gas compartment.<br/>                 Grab handle – (2) heavy duty type handles with chrome plated finish.</p> <p><b>Marker Light:</b><br/>                 2-diode LED.<br/>                 Amber color for front of body.<br/>                 Red color for front of body.<br/>                 Meet federal lighting requirements.</p> <p><b>Stop/Turn/Taillight:</b><br/>                 Flush mounted, 4-inch round, 7-diode LED.<br/>                 Meet federal lighting requirements.</p> <p><b>Back-up Light:</b><br/>                 Flush mounted, 4" round, white.<br/>                 Meet federal lighting requirements.</p> <p><b>Fender Area:</b><br/>                 Fenderettes – Molded high impact ABS.</p> <p><b>Prime / Paint:</b><br/>                 Primed inside and outside with universal weathering.<br/>                 polyurethane primer.<br/>                 Full undercoating.</p> <p><b>Conspicuity Tape:</b><br/>                 Install Conspicuity tape on the rear on the bed. 12-feet minimum.</p> | <hr/> <hr/> <hr/> <hr/> <hr/> <hr/> <hr/> <hr/> <hr/> <hr/> <hr/> <hr/> <hr/> <hr/> <hr/> <hr/> <hr/> <hr/> <hr/> <hr/> <hr/> <hr/> <hr/> <hr/> <hr/> |
| <p><b>Compartments</b></p>   | <p>Crane Service body shall have eight (8) compartments that will be structured according to the descriptions that follow. For convenience the compartments shall be referenced herein by alpha characters 1 thru 8, (Street side 1-4 Curbside 5-8). All Compartments shall have interior lights with control switch in cab.</p>   | <p><u>Describe:</u></p> <hr/> <hr/> <hr/> <hr/> <hr/> <hr/>   |
| <p><b>Compartment 1:</b></p> | <p>Approx. 36-inches wide X 21-inches deep X 48-inches height. Standard 42-inch shelf with two (2) adjustable shelves</p>  | <p><u>Describe:</u></p> <hr/> <hr/> <hr/> <hr/>   |
| <p><b>Compartment 2:</b></p> | <p>Approx. 22-inches wide x 20-inches deep x 48-inches height. Standard 42-inch shelf with three (3) adjustable shelves.</p>   | <p><u>Describe:</u></p> <hr/> <hr/> <hr/> <hr/>   |
| <p><b>Compartment 3:</b></p> | <p>Approx. 52-inches wide x 20-inches deep x 23-inches height. Divided tray for small parts.</p>   | <p><u>Describe:</u></p> <hr/> <hr/> <hr/> <hr/>   |
| <p><b>Compartment 4:</b></p> | <p>Approx. 25-inches wide x 20-inches deep x 48-inches height. Open compartment with three (3) material hooks. This compartment provides crane reinforcement with no obstruction in usable space. Install shelf brackets minus shelves.</p>  | <p><u>Describe:</u></p> <hr/> <hr/> <hr/> <hr/> <hr/> <hr/>   |
| <p><b>Compartment 5:</b></p> | <p>Approx. 31-inches wide x 20-inches deep x 48-inches height. Six (6) drawer parts cabinet. Three drawers shall</p>   | <p><u>Describe:</u></p> <hr/> <hr/> <hr/> <hr/>   |

|   |  |   |
|---|--|---|
|   | be 4-inches high, and Three drawers shall be 6-inches high. Each drawer shall have adjustable dividers.  | _____   |
| <b>Compartment 6:</b>   | Approx. 24-inches wide x 20-inches deep x 48-inches height. One shelf with divider.  | <u>Describe:</u><br>_____<br>_____  |
| <b>Compartment 7:</b>   | Approx. 52-inches wide x 20-inches deep x 23-inches height. Divided tray for small parts.  | <u>Describe:</u><br>_____<br>_____  |
| <b>Compartment 8:</b>   | Approx. 25-inches wide x 20-inches deep x 48-inches height. Open space with three (3) material hooks. (Install shelf brackets minus shelves)   | <u>Describe:</u><br>_____<br>_____  |
| <b>Lights and Reflectors</b>                                      | Dual wheel, standard lighting recessed and in accordance with all State of Oklahoma and Federal laws governing highway safety. Install Conspicuity tape on the rear on the bed. 12-foot minimum.   | <u>Describe:</u><br>_____<br>_____  |
| <b>Optional Features:<br/>(Price separately on Pricing page.)</b> | <ol style="list-style-type: none"> <li>1. Master Lock System, capability to lock all service body doors on one (1) side with one location.</li> <li>2. Shelving package for 38K Body, consisting of:<br/>11 adjustable shelves<br/>1 shelf with small parts dividers<br/>1 shelf with book dividers<br/>3 material hooks</li> <li>3. Tool tray 500-lb. rollout capacity, Latch closed.</li> <li>4. Drop well – to increase front compartments to 60-inches tall for storage of gas bottles.</li> <li>5. Bottle holders for secure storage of gas bottles.</li> <li>6. Compartment lighting – Rope light in each compartment with switch in Compartment 4.</li> <li>7. Flood light – quartz type, 100,000 candle power, 2 lights with switch in compartment 4.</li> <li>8. Crane boom support – adjustable to stowed boom angle.</li> <li>9. Bumper: 24-inch workbench type with: Vise plate and storage compartment with lock. 10-ga. A40-galvanneal steel top plate Adhesive-back skid tapes for slip resistance Integral full body-width step with galvanized steel open tread floor grating and a plate of enough thickness and strength to mount an approximate 16,000 lb. capacity pintle type hitch.</li> <li>10. Bumper: 12-inch type with: 10-ga. A40-galvanneal steel top plate Adhesive-back skid tapes for slip resistance Integral full body-width step with galvanized steel open tread floor grating</li> <li>11. Furnish and install a 16,000 lb. Ball combination pintle hitch such as a Buyers or Kernis model with a 2 5/16-inch ball mounted to rear of body. Include all materials required for mounting. Provide a 6 way round pin plug connector.</li> <li>12. Valve key brackets shall be mounted above compartments on street side of vehicle. Brackets shall</li> </ol> | <u>Describe:</u><br><ol style="list-style-type: none"> <li>1 _____</li> <li>2 _____</li> <li>3 _____</li> <li>4 _____</li> <li>5 _____</li> <li>6 _____</li> <li>7 _____</li> <li>8 _____</li> <li>9 _____</li> <li>10 _____</li> <li>11 _____</li> <li>12 _____</li> </ol> |

|  |   |   |
|--|---|---|
|  | <p>be mounted level, in a manner that provides use of entire length of body for longer keys. Brackets shall have a minimum of six (6) slots for keys and must provide positive locking mechanisms for securing keys.</p> <p>13. Ladder brackets shall be installed in interior of bed of truck on street side. Brackets shall be level to accommodate a twelve-foot ladder.</p> | <p>_____</p> <p>_____</p> <p>_____</p> <p>_____</p> <p>13</p> <p>_____</p> <p>_____</p> |
|--|---|---|

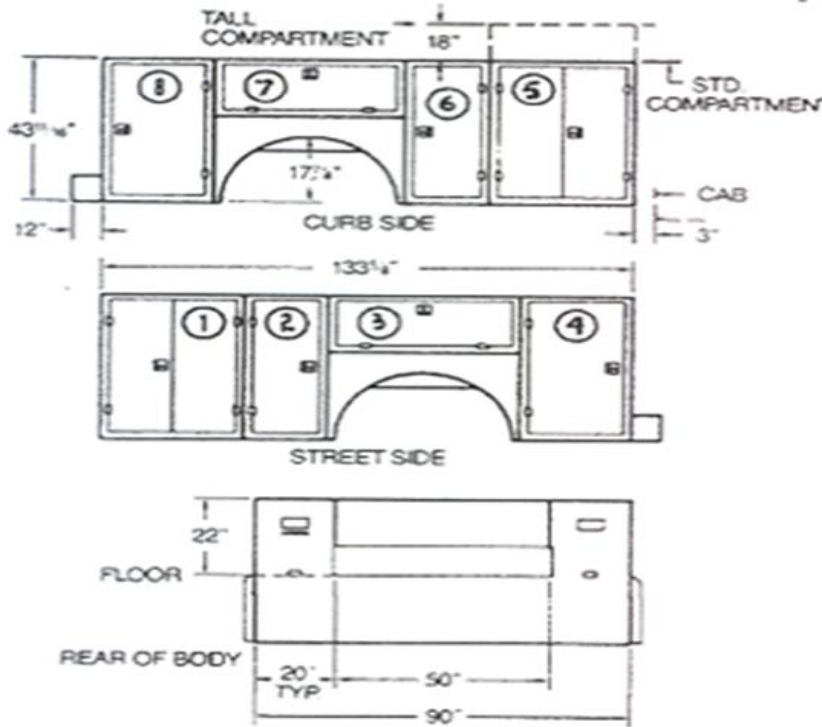

Storage space: 60" CA – 84.5 cu. ft.; 84" CA – 105.8 cu. ft.  
 Minimum chassis requirements: 10,500 lbs. GVWR; 34" frame rail width; dual rear wheels (89"–91 1/4" overall width); 14,500 lb. chassis required for cranes in excess of 25,000 ft. lbs. Chassis requirements will vary depending upon crane used with body. Truck stability will govern the actual approved working loads which will apply at different points of rotation.

**Item 27: Crane Body std. 50,000 ft/lb.**

| Item                              | Specifications (Minimum)  | Bidder's Proposal  |
|-----------------------------------|---|--|
| <p><b>General Description</b></p> | <p>This Specification shall provide for new 50K series crane body, the latest current production model. Complete with manufacturer's standard equipment and accessories, fully serviced ready to operate. To include manufacturer's certificate or warranty. (Warranty shall be the standard for the industry as offered to the public.) This body shall be</p> | <p><u>Describe:</u></p> <p>_____</p> <p>_____</p> <p>_____</p> <p>_____</p> <p>_____</p> |

|                                 |  |  |
|---------------------------------|--|--|
|                                 | equipped to meet all Federal and State of Oklahoma Safety Standards and Requirements. No dealer advertisement shall be affixed to the Bid. Conspicuity Reflective tape shall be applied to rear of all bodies for safety.  | _____  |
| <b>Model</b>                    | 120 Inch CA, 50,000 FT LBS Series Crane Body or acceptable equal, installed on a 33,000 GVW Truck. <u>The truck will very likely require a 126" Cab to Axle to allow room for the exhaust bracket if mounted on International trucks.</u><br><u>Batteries may have to be mounted in right front compartment if not mounted under cab.</u>  | <u>Describe:</u><br>_____<br>_____<br>_____<br>_____<br>_____  |
| <b>Capacity</b>                 | Capable of handling up to 50,400 ft-lb. of crane moment load in all positions of rotation Be stable with full-load crane with rear outriggers fully deployed when mounted on adequate chassis as specified below. The use of front corner outrigger is not necessary.<br>CRANE NOT INCLUDED IN SPECIFICATION.  | <u>Describe:</u><br>_____<br>_____<br>_____<br>_____<br>_____  |
| <b>Structural Requirements:</b> | Body shall have integrated support structure capable of handling the rated moment load in all positions without permanent deflection.<br><br>One-piece continuous longitudinal frame with 4-inches x 4-inches x .25-inches wall square structural tubing.<br><br>Structural cross sills consist of:<br>5-inches x 3-inches x .38-inches tubing.<br>5-inches x 6.7# channels.<br><br>Compartment beneath crane is to be unobstructed by structural reinforcements. Crane reinforcement shall be constructed of .38-inches formed steel plates with .50-inches minimum steel plate for compartment top beneath crane.<br><br>Body sheet metal shall be A40-galvanneal steel with a minimum of:<br>10-ga. formed one-piece continuous sides with integral ends. 11-ga. tread plate on all sides of cargo area and top of compartments. (Ref. Cargo Area above.) 14-ga. door frames with integral compartment dividers<br><br>Doors – double paneled, A40-galvanneal steel: 10-ga. For outer | <u>Describe:</u><br>_____<br>_____<br>_____<br>_____<br>_____<br>_____<br>_____<br>_____<br>_____<br>_____<br>_____<br>_____<br>_____<br>_____<br>_____<br>_____ |
| <b>Standard Features:</b>       | <b>Overall dimensions:</b> (LxWxH) 169-inches X 94-inches X 58-inches.<br>Overall compartment depth: 22-inches approx.<br><b>Weight (approximate):</b> 3,940 lbs. For 58-inches Tall   | <u>Describe:</u><br>_____<br>_____<br>_____  |



|                       |  |  |
|-----------------------|--|--|
| <b>Compartment B:</b> | 36 3/8-inches wide x 21 1/8-inches deep x 58-inches height standard with two (2) adjustable shelves.   | <u>Describe:</u><br>_____<br>_____   |
| <b>Compartment C:</b> | 21 3/16-inches wide x 21 1/8-inches deep x 58-inches height. Three (3) adjustable shelves.   | <u>Describe:</u><br>_____<br>_____   |
| <b>Compartment D</b>  | 47 5/8-inches wide x 21 1/8-inches deep x 31-inches height. One shelf with dividers.   | <u>Describe:</u><br>_____<br>_____   |
| <b>Compartment E:</b> | 27 3/8-inches wide x 21 1/8-inches deep x 58-inches height. Open space with three (3) material hooks. (Install shelf brackets minus shelves)   | <u>Describe:</u><br>_____<br>_____   |
| <b>Compartment F:</b> | Manufacturer's Standard, Open Space, full width compartment. Door hinged on side to open to the right. Greaseable hinge.   | <u>Describe:</u><br>_____<br>_____   |
| <b>Compartment G</b>  | 36-inches wide x 47-inches deep x 58-inches height. Transverse box with water pump rollout tray. (See drawings I, II & III for details). Tray shall be designed and constructed to support minimum 150 lb. load and shall have spring mechanism to support portion of load while tray is being raised and lowered. Stop guides shall be included on tray rollout to prevent tray from leaving track. Pump tray to be at bottom of compartment closest to the ground, 2 compartment vents included. | <u>Describe:</u><br>_____<br>_____<br>_____<br>_____<br>_____<br>_____<br>_____<br>_____ |
| <b>Compartment H:</b> | 36 3/8-inches wide x 21 1/8-inches deep x 58-inches height. Twelve (12) drawer parts cabinet. Six drawers shall be 4-inches high, and six drawers shall be 6-inches high. Each drawer shall have adjustable dividers.  | <u>Describe:</u><br>_____<br>_____<br>_____  |
| <b>Compartment I:</b> | 21 3/16-inches x 21 1/8-inches deep x 58-inches height. Standard 60-inch shelf with three (3) adjustable shelves.  | <u>Describe:</u><br>_____<br>_____   |
| <b>Compartment J:</b> | 47 5/8-inches wide x 21 1/8-inches deep x 31-inch height. Divided tray for small parts.  | <u>Describe:</u><br>_____<br>_____   |
| <b>Compartment K:</b> | 26 1/4-inches wide x 21 1/16-inches deep x 58-inch height. Open compartment with three (3) material hooks. This compartment provides crane reinforcement with no obstruction in usable space. Install shelf brackets minus shelves.  | <u>Describe:</u><br>_____<br>_____<br>_____<br>_____                                     |
| <b>Compartment L:</b> | 36-inches wide x 54-inches length x 18-inches height. Top opening lid with gas prop lid holder. Two (2) full length dividers.  | <u>Describe:</u><br>_____<br>_____<br>_____  |
| <b>Rear Bumper:</b>   | Install a steel fabricated rear 12-inch heavy duty bumper. Bumper to be boxed in with a recess area to allow up to 90,000 lb. air pintle hitch to be mounted. Provide a method for safety hooks to be utilized.  | <u>Describe:</u><br>_____<br>_____<br>_____  |



|                               |  |   |
|-------------------------------|--|---|
|                               | Provide a step on one side of the bumper to allow climbing onto the bumper and then into the bed of the body. Include a grab handle on the body for use with the step.   | <hr/> <hr/> <hr/> <hr/>   |
| <b>Lights and Reflectors</b>  | Dual wheel, standard lighting recessed and in accordance with all State of Oklahoma and Federal laws governing highway safety. Install Conspicuity tape on the rear on the bed. 12-foot minimum.   | <u>Describe:</u><br><hr/> <hr/> <hr/> <hr/>   |
| <b>Additional Information</b> | <ol style="list-style-type: none"> <li>1. All slide out trays and trays in boxes to have heavy duty latches and rollers.</li> <li>2. Bed floor, tailgate, and bumper to have a non-skid surface applied.</li> <li>3. A retractable step to be installed on rear bumper and under toolbox area for easy accessibility.</li> <li>4. Conspicuity Reflective Safety Tape material shall be added to the rear portions of all bodies for safety.</li> </ol>   | <u>Describe:</u><br>1 <hr/><br>2 <hr/><br>3 <hr/><br>4 <hr/><br>  |
| <b>Options:</b>               | <ol style="list-style-type: none"> <li>1. Master Lock System, capability to lock all service body doors on one (1) side with one location.</li> <li>2. Shelving: Shelving package consisting of: <ol style="list-style-type: none"> <li>(11) adjustable shelves</li> <li>(1) shelf with small parts dividers</li> <li>(1) shelf with book dividers</li> <li>(3) material hooks</li> </ol> </li> <li>3. Tool Tray: Tool tray in driver's side, front compartment. 500-lbs rollout capacity Latch closed.</li> <li>4. Drop Well: Drop well – to increase front compartments to 60-inches tall for storage of gas bottles, 2nd compartment curbside.</li> <li>5. Bottle Holders: Bottle holders for secure storage of gas bottles 2nd compartment curb side.</li> <li>6. Compartment. Lights: Compartment lighting – rope light both sides.</li> <li>7. Flood Lights: Flood light – quartz type, 100,000 candle power- 2 lights, curbside</li> <li>8. Additional Lighting: A minimum of four (4) Extra Lights shall be provided at rear of body if rear portion of body is sprayed with Rhino type lining.</li> <li>9. Crane Support: Crane boom support – adjustable to stowed boom angle.</li> <li>10. Bumper: 24" workbench type with vise plate and storage compartment 10-ga. A40-galvanneal steel. Rhino type non-skid spray on surface. Door latches – matching body door latches (See spec. in "Door Latches" section listed previously). Door hinged on side to open to the right. Greaseable hinge. Interior latch protection.</li> <li>11. Valve Key Brackets: Valve key brackets shall be mounted above compartments on street side of vehicle. Brackets shall be mounted level, in a manner that provides use of entire length of body for longer keys. Brackets shall have a minimum of six (6) slots for keys</li> </ol> | <u>Describe:</u><br>1 <hr/><br>2 <hr/><br>3 <hr/><br>4 <hr/><br>5 <hr/><br>6 <hr/><br>7 <hr/><br>8 <hr/><br>9 <hr/><br>11 <hr/><br> |

|     |   |     |
|-----|---|-----|
|     | and must provide positive locking mechanisms for securing keys.   |     |
| 12. | Ladder Brackets: Ladder brackets shall be installed in interior of bed of truck on street side. Brackets shall be level to accommodate a twelve (12) foot ladder.   | 12  |
| 13. | Pintle Hitch: 16,000 lb. Buyers or Kernis 2-5/16-inch Ball Combination Pintle Hitch. Include glad hands and 6- way light connection with 7-way adapter.   | 13  |
| 14. | Air Pintle Hitch: Hitch: 90,000 lb. Holland PH210 air operated pintle hitch. Provide glad hands and electrical 7-way connection at rear of truck.   | 14  |
| 15. | Delete Drawers: Delete drawers in lieu of open compartment "H".   | 15  |
| 16. | Slide Out Shelf: Delete standard shelving in compartment "D" and "J" and add a 250 lb. capacity slide out shelf and split doors on the outside in place of the single door.   | 16  |
| 17. | Spray-On Liner: A black spray on liner type non-skid surface material shall be applied to the following to prevent rust. The outside compartment panels will not be sprayed with non-skid liner but will be painted white to match the truck.   | 17  |
|     | 17A. Cargo area including bed floor, tailgate, sides and bulkhead.  | 17A |
|     | 18B. Rear Bumper, rear body partitions where lights are mounted, and tops of all toolboxes.   | 17B |
| 18. | Lift gate: A 1,600 lb. standard type lift gate. Same as Item 15G. Mounted at rear of body. Frame height 40-inches approx.   | 18  |
| 19. | Labor to Mount: Lift gate Option 17 above to Crane Body. (Only if the Crane and out-riggers options are selected).  | 19  |
| 20. | Rotary Screw Compressor: Furnish and install an Auto Crane rotary screw air compressor model number VMAC60 CFM or equal with hydraulic drive, air shift PTO, 23-gallon hydraulic reservoir, FLR system, Hydraulic hose kit on top of compartment G which is located at curbside, front of body (see drawings). Display gauges must face out to curbside and be seen from the ground. Compressor must be plumbed to the air hoses. Furnish and mounted the air hoses on a reel and mount it on top of compartment J towards rear 1/2. An acetylene/oxygen hose & reel will be mounted next to it over front part of compartment. (See drawings below.) The hoses for the underbody reserve air tank and hydraulic tank are to be plumbed as well. Quick connects required at all connections. All plumbing to the hose reels shall be secured and protected by means of a metal channel type removable covering for protection and ease of maintenance. The hoses shall be routed along the outer top edge of the toolboxes. No components shall be exposed to the elements. All parts are to be painted white to match the truck color. | 20  |

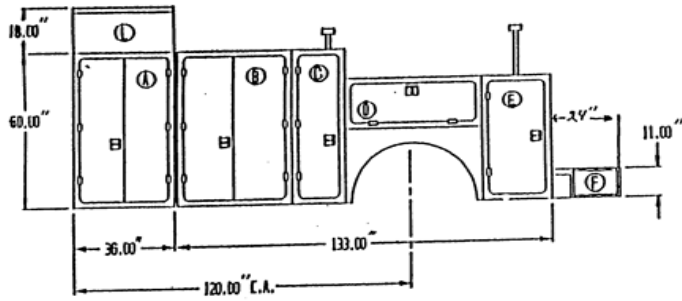

STREET SIDE

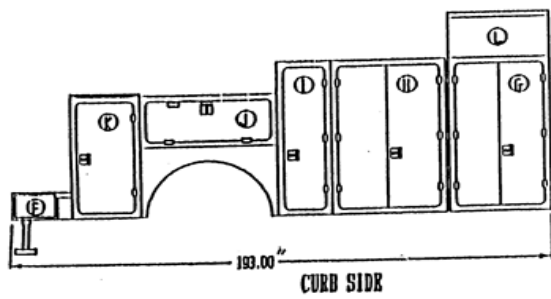

CURB SIDE

DRAWING I

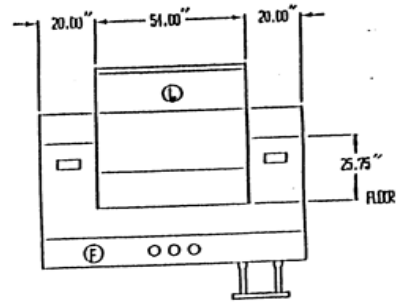

REAR OF BODY

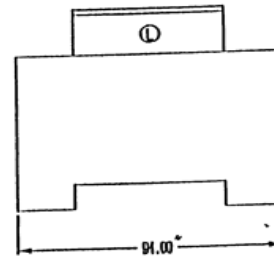

FRONT OF BODY

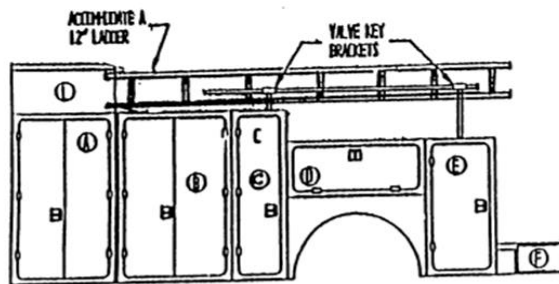

STREET SIDE

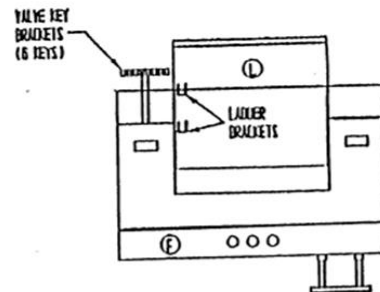

REAR OF BODY

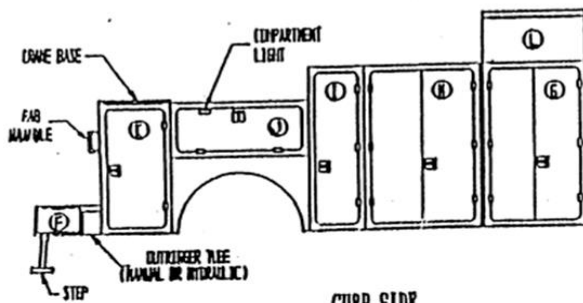

CURB SIDE

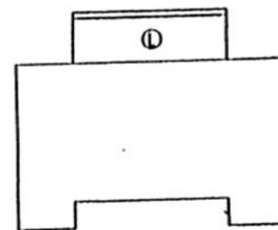

FRONT OF BODY

DRAWING II

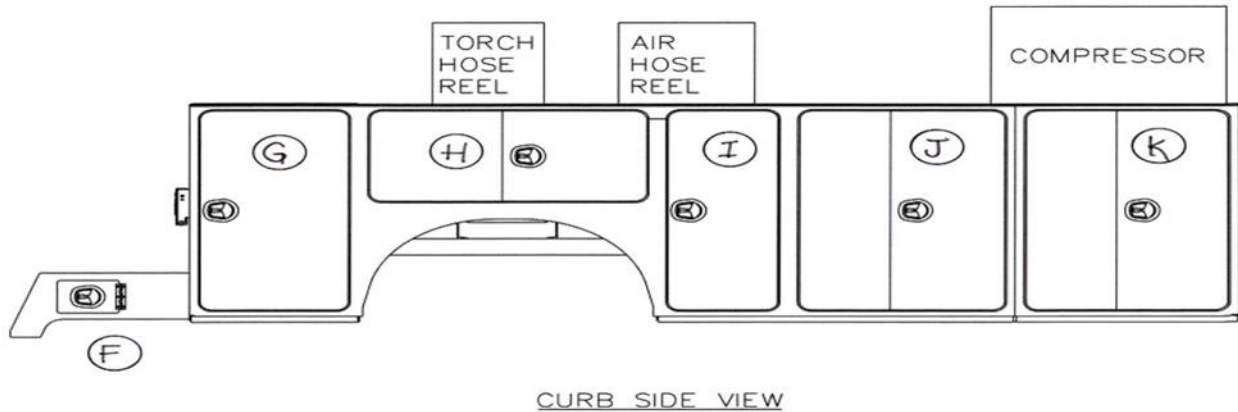
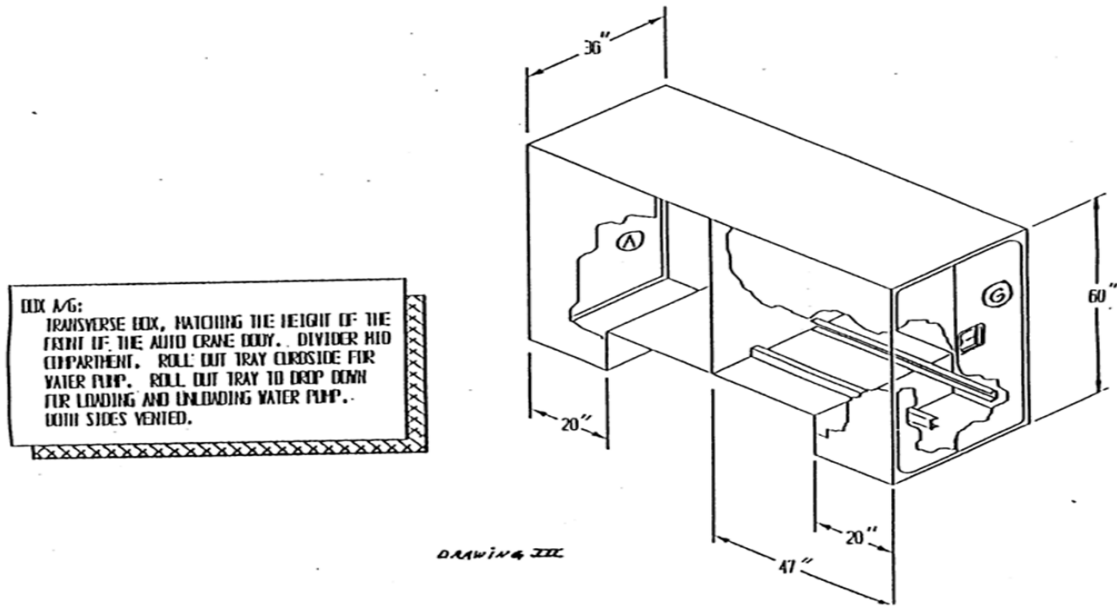

MAIN LINE 50K BODY STANDARD

**Item 28: 5 Cubic Yard Steel Dump Body-84"CA**

| Item                              | Specifications (Minimum)  | Bidder's Proposal   |
|-----------------------------------|---|---|
| <p><b>General Description</b></p> | <p>This Specification shall provide for a New latest current production model, <u>Western/Crossmember less Style</u>, steel, hydraulic dump beds for a transmission mounted PTO and an 84" CA. Complete with manufacturer's standard equipment and accessories, fully serviced ready to operate. To include manufacturer's certificate or warranty and be bid less all applicable State and Federal Taxes. This body shall be equipment to meet all Federal and State of Oklahoma</p> | <p><u>Describe:</u></p> <hr/> <hr/> <hr/> <hr/> <hr/> <hr/> <hr/> |

|                                 |   |                                    |
|---------------------------------|---|------------------------------------|
|                                 | Safety Standards and Requirements. No dealer advertisement shall be affixed to the bed.   | _____<br>_____<br>_____            |
| <b>Body Size:<br/>Capacity:</b> | Five (5) Cubic Yard Water Level with six (6) Cubic yard Front and Tailgate.   | <u>Describe:</u><br>_____<br>_____ |
| <b>Length:</b>                  | 10-Feet.  | <u>Describe:</u><br>_____<br>_____ |
| <b>Width Inside:</b>            | 87-Inches.  | <u>Describe:</u><br>_____<br>_____ |
| <b>Body Head Height:</b>        | 40-inches approx.   | <u>Describe:</u><br>_____<br>_____ |
| <b>Tail Gate Height:</b>        | 32-Inches approx.   | <u>Describe:</u><br>_____<br>_____ |
| <b>Side Height:</b>             | 26-Inches, 4-bend(boxed) top rail, continuous steel with dirt shedding top.   | <u>Describe:</u><br>_____<br>_____ |
| <b>Steel Specification:</b>     | 7 Gauge floor, 10 gauge sides and ends. With Made od A1011 Steel.   | <u>Describe:</u><br>_____<br>_____ |
| <b>Floor:</b>                   | Six (6-inch) approx. radius floor to sidewall for easy cleanout.  | <u>Describe:</u><br>_____<br>_____ |
| <b>Longitudinals:</b>           | 9-inch, 7-gauge A1011 Channel Steel.  | <u>Describe:</u><br>_____<br>_____ |
| <b>Corner Posts Rear:</b>       | 2 Each, Approx. 12 3/4-Inches, full depth with extra braces with 2 spreader chains, dirt shedding top.  | <u>Describe:</u><br>_____<br>_____ |
| <b>Corner Posts Front:</b>      | Full depth, Approx. 8-inches wide with 4-inch radius, dirt shedding top.  | <u>Describe:</u><br>_____<br>_____ |
| <b>Grab Handles:</b>            | Two (2), one on each side of gate.  | <u>Describe:</u><br>_____<br>_____ |
| <b>Rub Rails:</b>               | Full length 30-degrees Minimum Slope.   | <u>Describe:</u><br>_____<br>_____ |
| <b>Light Reflectors:</b>        | Four (4), one each corner, 2 front and 2 rear, Interstate Commerce Commission approved. Install Conspicuity tape across the rear of the bed. 12-feet minimum.                         | <u>Describe:</u><br>_____<br>_____ |
| <b>Control Lever:</b>           | Locking lever pedestal control with 1/4-inch sealed cable.  | <u>Describe:</u><br>_____<br>_____ |
| <b>Banjo Eyes:</b>              | Four (4), 2 Each Side 3/8-inch steel, 4-3/8-inch x 5-inch and extend beyond Rear Post.  | <u>Describe:</u><br>_____<br>_____ |
| <b>Sideboard Gussets:</b>       | Four (4) Each, 6-inches High x 3-inches Wide.   | <u>Describe:</u><br>_____<br>_____ |
| <b>Sideboards Extensions:</b>   | Install 2-inch Oak boards tapered from front to rear of bed. Boards to be tapered so that the area from the front of the bed to allow smooth operation of a roll up type tarp system. | <u>Describe:</u><br>_____<br>_____ |

|                            |  |  |
|----------------------------|--|--|
| <b>Tail Gate:</b>          | Double Acting with 2 Vertical Braces and 1 horizontal brace, sloped, dirt shedding at the top  | <u>Describe:</u><br>_____<br>_____   |
| <b>NOTE:</b>               | When Tailgate is hinged from the bottom, it must not have a gap where material can fall out  | <u>Describe:</u><br>_____<br>_____   |
| <b>Tail Gate Hardware:</b> | 1-inch. Grease zerk lubricated top hardware; 1-inch lower hardware pivoting on 1 ¼-inch (C1045) shaft, zerk lubricated on both ends.   | <u>Describe:</u><br>_____<br>_____   |
| <b>Air Tailgate:</b>       | Air operated tailgate release with in-cab control. The unit shall have an air activated tailgate latch, utilizing a 3-1/2-inch x 8-inch non-tie rod cylinder. The pneumatic cylinder shall be retracted when the latch is closed and shall be located at the rear of the bed to minimize the necessary linkage. The linkage shall be specifically designed to operate with the pneumatic cylinder.   | <u>Describe:</u><br>_____<br>_____<br>_____<br>_____<br>_____                            |
| <b>Tie Down Rail:</b>      | Full length both sides to be 5/8-inch reinforcing bar, 3-inch high from extreme top outer edge of Rub Rail.  | <u>Describe:</u><br>_____<br>_____   |
| <b>Folding Ladder</b>      | Qty of Two (2) 20-inch, four-inch-wide metal grip strut steps attached on the front right-hand side of the body. Install a slide out, two (2) rung ladder, mounted under the body just below the steps. The slide out ladder shall be on a hinged mechanism that has a positive latch system and will be locked in storage mode or when retracted out will hinge down and be locked in a stable configuration for safe utilization and accessible from the ground. The steps and the 2 rungs, ladder will allow access from the ground to the top of the body. | <u>Describe:</u><br>_____<br>_____<br>_____<br>_____<br>_____<br>_____<br>_____<br>_____ |
| <b>Lights:</b>             | All lights to be LED, plus stop/turn lights flush mounted in the rear corner pillars. Shock resistant, rubber mounted. Factory stop/turn/back up lights installed outside truck frame rails and protected with expanded metal. All lights must meet Federal Motor Vehicle Safety Standards.  | <u>Describe:</u><br>_____<br>_____<br>_____<br>_____                                     |
| <b>Light Wiring:</b>       | Joints soldered and shrink-wrapped, in a plastic convoluted loom protective covering.  | <u>Describe:</u><br>_____<br>_____   |
| <b>Mud Flaps:</b>          | Qty of 2 - One on each side, 24-inch X 30-inch Non-Sail Type. To be without any advertisement. One each mounted on each side to the rear of the tires, Non-Sail type and prevented from becoming entangled in the tires.   | <u>Describe:</u><br>_____<br>_____<br>_____  |
| <b>Electric Tarp Kit</b>   | Donovan 7000ELD electric tarp kit or approved equal with control box, and a wind deflector- 16-gauge galvanized steel. A 3/16" removeable plate shall be installed over the top of the tarp roll up mechanism to protect it from damage.   | <u>Describe:</u><br>_____<br>_____<br>_____  |
| <b>Safety Strut:</b>       | All dump beds must be equipped with safety strut to hold bed in the "UP" position while repairs are being made.  | <u>Describe:</u><br>_____<br>_____   |

|   |   |  |
|---|---|--|
| <p><b>Spreader Tie Down “D” Rings</b></p>   | <p>Install (4) 1/2-inch dia. “D” Rings on lower rub rail; 2 on each side with one mounted 24” from the front and one mounted 24” from the rear of body. Must have the capability of ratcheting the spreader chains from a standing position on the ground.</p>  | <p><u>Describe:</u><br/>                 _____<br/>                 _____<br/>                 _____<br/>                 _____</p>  |
| <p><b>Cab Shield:</b></p>                   | <p>Full Cab Shield - Full Width of Bed.</p>   | <p><u>Describe:</u><br/>                 _____<br/>                 _____</p>  |
| <p><b>Trailer Tow Pkg.:</b></p>             | <p>Complete trailer package for pulling air brake trailers. To include air lines plumbed to rear of frame from the factory source (To be supplied by the truck manufacturer). Furnish and install glad hands and 7-way electrical connector at rear of frame ready to use with a 6 to 7-way adaptor. Air couplers and electrical connections are to be mounted as high as possible in the hinge area and plumbed in such a way as to not interfere with dumping of the bed or sand spreader operation and to avoid contact when pulling trailers.</p> | <p><u>Describe:</u><br/>                 _____<br/>                 _____<br/>                 _____<br/>                 _____<br/>                 _____<br/>                 _____<br/>                 _____</p> |
| <p><b>Pintle Hitch:</b></p>                 | <p>Reinforced trailer hitch mounted on a 5/8-inch plate, gusseted, with a 90,000 lb. air pintle hitch, Holland PH210 or equal. Trailer safety rings are Crosby weldless links per Item 21 of this IFB to match capacity of hitch. Air lines to have quick disconnect fittings behind air operated pintle hitch so hitch may be removed during certain operations of the dump truck such as spreader operations.</p>   | <p><u>Describe:</u><br/>                 _____<br/>                 _____<br/>                 _____<br/>                 _____<br/>                 _____<br/>                 _____</p>                            |
| <p><b>Strobes, Front &amp; Rear:</b></p>    | <p>Furnish and install LED strobes on each side in rear corner pillars and front grill area of truck per Item 5, options 5K and 5L of this IFB.</p>   | <p><u>Describe:</u><br/>                 _____<br/>                 _____<br/>                 _____</p>   |
| <p><b>Warranty:</b></p>                     | <p>Body manufacturer shall provide a written 5-year warranty covering repair or replacement of the body, hoist and air cylinder for defective material and/or workmanship. Warranty shall include all freight and labor for repairs or replacement. Warranty shall also include adherence of primer to all metal surfaces not including inside or understructure of dump bodies. The manufacturer’s warranty <u>must</u> be submitted with Bid.</p>   | <p><u>Describe:</u><br/>                 _____<br/>                 _____<br/>                 _____<br/>                 _____<br/>                 _____<br/>                 _____<br/>                 _____</p> |
| <p><b>Note:</b></p>                         | <p>Warranty labor and parts replacement must be handled by an in-state authorized dealer, who can provide immediate replacement without charge or delay. “See Specification Header at beginning of Bid Specifications”.</p>   | <p><u>Describe:</u><br/>                 _____<br/>                 _____<br/>                 _____<br/>                 _____</p>  |
| <p><b>Hydraulic Hoist, Frame, Pump:</b></p> | <p>Minimum of a Class 50</p>  | <p><u>Describe:</u><br/>                 _____<br/>                 _____<br/>                 _____</p>   |
| <p><b>Body Hoist:</b></p>                   | <p>Scissor Type.</p>  | <p><u>Describe:</u><br/>                 _____<br/>                 _____</p>  |
| <p><b>Dumping Angle:</b></p>                | <p>50 Degrees.</p>  | <p><u>Describe:</u><br/>                 _____<br/>                 _____</p>  |

|  |  |  |
|--|--|--|
| <b>Hydraulic Pump:</b>                   | Gear type 6 GPM @ 1000 RPM & 2250 PSI. Pump to be mounted directly on PTO.   | <u>Describe:</u><br>_____<br>_____   |
| <b>Shaft Bearings:</b>                   | Roller Bearing, Antifriction   | <u>Describe:</u><br>_____  |
| <b>Oil Reservoir:</b>                    | Capacity 10 gallons, approx., with filtered return line, shut off valve on suction port.   | <u>Describe:</u><br>_____<br>_____   |
| <b>Low Hydraulic Fluid Warning Light</b> | Must install in the cab a Low Hydraulic Fluid Warning Light within easy view of driver.  | <u>Describe:</u><br>_____<br>_____   |
| <b>Hoist to Be:</b>                      | Class 50 Min., power up/power down. National Truck Equipment Association approved.   | <u>Describe:</u><br>_____<br>_____   |
| <b>Controls:</b>                         | Locking lever pedestal controls with <u>Body Up</u> audio and visual alarm. A locking device to lock controls in neutral position shall be provided. Control and valve connected with a 1/4-inch sealed cable.   | <u>Describe:</u><br>_____<br>_____<br>_____  |
| <b>Power Take-Off:</b>                   | Direct driven from transmission to hydraulic pump. PTO to have enabler capability (i.e. "Hot Shift" Type) with electronic "overspeed protection" to prevent PTO from turning at more RPM than system is designed to handle. Must be geared to allow continuous operation at 0-30 MPH. Electronic dash mounted controls with engagement light, no levers or cables, must be able to shift PTO while truck is in motion 15 to 20 MPH.  | <u>Describe:</u><br>_____<br>_____<br>_____<br>_____<br>_____<br>_____   |
| <b>Over-Speed Protection for P.T.O.</b>  | Fully adjustable from 300 to 3000 RPM.   | <u>Describe:</u><br>_____<br>_____   |
| <b>Options</b>                           | <ol style="list-style-type: none"> <li>1. <u>Central Hydraulic System with Quick Disconnect:</u><br/>Muncie MP2 central hydraulic system or acceptable equal capable of operating the dump body hoist, snow plow up/down/left/right and sand spreader spinner and conveyor. (see specification below) ** Air controls option for feathering the bed not required if installing a Central Hydraulic System with Quick Disconnect.</li> <li>2. <u>Spread Apron:</u><br/>12-inch Spread Apron, 10 ga. Steel.</li> <li>3. <u>Ball Hitch:</u><br/>Reinforced trailer hitch mounted on a 5/8-inch plate, gusseted, with a Buyers or Kernis K300 2 5/16-inch ball hitch rated at 16,000 LB. Trailer safety rings are Crosby weldless links per Item 21 to match capacity of hitch.</li> <li>4. <u>Toolbox:</u><br/>Frame mounted toolbox, 36-inches x 18-inches x 18-inches, Rawson-Koenig H361818 or equal.</li> <li>5. <u>Sideboards:</u><br/>A. In place of the 2" Oak Boards, install Rumber type material 2-inch boards tapered from front to rear of</li> </ol> | <u>Describe:</u><br><ol style="list-style-type: none"> <li>1 _____</li> <li>2 _____</li> <li>3 _____</li> <li>4 _____</li> <li>5 _____</li> <li>A _____</li> </ol> |







**\*\*Hydraulic Central Control System for Snow and Ice Equipment:**

Install a Muncie MP2 central hydraulic system or acceptable equal capable of operating the dump body hoist, snow plow up/down/left/right and sand spreader spinner and conveyor.

The sand spreader system shall contain a 3/4-inch pressure line for the spinner and a 3/4-inch pressure line for the conveyor and a single 1-inch return line. These lines will be hard piped from the hoist area to the rear of the truck. The spinner quick connect shall be an Eaton #5602-12-12S or acceptable equal. The conveyor quick connect shall be an Eaton #5601-12-12S or acceptable equal. The return quick connect shall be an Eaton #5602-16-16S or acceptable equal. All quick connects must be compatible with existing quick connects of same size being utilized in the current fleet of trucks so all sand spreaders units are compatible with any truck utilized. All quick connects are to be mounted on the rear curbside of the dump body approximately 10-inches from the rear (contact a City of Tulsa representative for an exact location. All quick connects to have a protective cover. These quick connects shall be mounted so they will not interfere with dumping of the bed or with use of the Pintle Hitch.

The Hydraulic Valving shall be as follows. The circuit design shall include Load-Sensing communication from all valves. The valves shall be solenoid operated carriage style with a common manifold and rated IP69. There shall be a flow priority to insure operation of the cylinder functions whenever the spreader is operating, and pump flow is critically low. All cylinders shall have proportional flow control on the power sequence to afford cylinder speed control. Pressure relief valves shall have an independent stem adjustable pressure protection included for the manifold inlet, the spreader, the downside of all double acting cylinders and plow angle cylinders. The plow lift valves shall be capable of four- way control and have a flow capacity of 15 gallons per minute (GPM). The raise side of the circuit shall be rated for zero leakage. The plow angle valves shall be capable of four- way control and have a flow capacity of 15 GPM. Load Locking check valves or Motor Spool design shall be included as required to support the angling mechanism used. The dump hoist valves shall have a four-way control and have a flow capacity of 30 GPM. Counterbalance control valves shall be included. The spreader proportional control valves for the auger, conveyor and spinner motor shall have a flow capacity of 15/7 GPM respectively. These valves shall be pressure compensated and parallel in their circuit architecture. The System Controls commands to the system valves shall be digitally encoded and sent over the vehicles electrical system using only a 12-volt DC and ground connection at each end of the system.

The valve driver modules shall be housed in Deutsch boxes employ Deutsch connectors at solenoids or acceptable equal giving IP69 environmental rating. The valve driver modules shall be equipped with current sensing control to offset thermal changes in solenoid performance and to detect open or short circuit conditions and protect against the latter by automatic interruption of current to the shorted output.

Cylinder momentary push button switches will provide on-off style control of the plow and dump body operations. Program settings will provide effective and independent flow trims for plow up-down, plow angle and dump up-down. A two-axis cylinder proportional joystick with dead man switch and pushbutton selection of equipment shall be provided. The joystick shall employ dual redundant hall-effect mechanisms, eliminating the wear of potentiometer or other contact mechanisms. In the event of failure of one hall-effect output a program adjustment to system controller will allow selection of the alternate channel. The same controller will also provide electronic adjustment of one degree from center for operation, minimum valve drive at minimum joystick deflection, and maximum valve drive at maximum joystick deflection. Adjustments for degrees from center operation and the minimum valve drive at minimum joystick deflection will be independent for the plow and dump. The joystick shall plug to the control panel as its only connection point. Connection of the joystick will render the pushbutton cylinder controls inoperable. Conversely, disconnection of the joystick will reactivate the pushbutton controls. Selection of the equipment function by pushbuttons on the head of the joystick will illuminate an equipment identity label on the control panel. No operation of the joystick can take place without holding the dead man switch.

The spreader controls modes of operation shall provide a selectable automatic and manual control. There shall be a Blast operation with programmable selection of level and time. A Pause operation shall be available to momentarily disable the spreader operation. A feedback sensor shall not be required to achieve accurate and consistent operation of the spreader functions.

High brightness LED numerical displays will be used to indicate one of 11 reference controls positions for the spinner and auger (manual mode). In Auto operation the auger display will indicate "pounds per mile" if the system has been

calibrated for such. The system shall display fault occurrences of shorted or open outputs at the valves with indication of which circuit is responsible.

All controls will be mounted in the truck cab. The joystick shall be mounted on a pedestal style mechanism beside the driver at a level and location that is comfortable to operate, allowing the driver to operate at a glance without taking his eyes completely off the road. The Control display panel shall be mounted in the dash area and at a level easily viewed by the driver.

An integral valve/tank enclosure assembly shall be mounted to the frame rail of the vehicle. The reservoir and dry compartment shall be made of 7-gauge mild powder coated steel and the lid assembly shall be made of 10-gauge mild powder coated steel painted black to match the frame rails.

The bottom portion of the valve/tank integral design shall house a minimum of 35 gallons of hydraulic oil with temperature/sight gauge mounted on the front face. The reservoir shall be properly baffled with a drain plug in the bottom and provision in the top for an in-tank, glass type return line filter. There shall also be a fill tube vented cap assembly that will also serve as a clean out port. The filter will be a minimum of 10 micron and the element shall be easily removed for replacement.

The top portion of the valve/tank assembly will be dry with a rubber seal that will provide protection when the lid assembly is in place. This area will house the tube/vented cap, return line in-tank filter, the solenoid control valve manifold, and the PLC electronic command modules.

The solenoid control manifold valve will mount in the enclosure against the back wall allowing for all cylinder and spreader hose connections to be mounted directly to this assembly. The back of the manifold assembly will be bolted to the back wall in a way to prevent outside contamination and to allow for the O ring fittings for hose connections to the direct entry eliminating the need for internal cylinder and spreader hose plumbing. The valve/tank assembly shall be narrow or stepped from the frame of the vehicle to allow for ample room for installation and servicing of the hoses. The PLC modules will be contained to the back wall of the enclosure and will allow for easy servicing. The wiring from the manifold cartridge solenoids will plug into these two modules and the power, ground, and ground speed control conductors will exit the enclosure with a strain relief sealed connector.

The lid will set on a perimeter gasket and will be retained with four over-center chrome latches for easy access and removal. The entire valve/tank enclosure will be mounted to the frame in a cradle fabricated by the installer to properly support the assembly.

**Item 29: 5 Cubic Yard Stainless Steel Dump Body-84-inchCA**

| Item                        | Specifications (Minimum)   | Bidder's Proposal   |
|-----------------------------|--|---|
| <b>General Description:</b> | This Specification shall provide for new, the latest current production model. <u>Western/Crossmemberless Style</u> Stainless Steel, hydraulic dump beds, complete with manufacturer's standard equipment and accessories, fully serviced ready to operate. To include manufacturer's certificate. (Warranty shall be the standard for the industry as offered to the public.) This body shall be equipment to meet all Federal and State of Oklahoma Safety Standards and requirement. No dealer advertisement shall be affixed to the bed. | <u>Describe:</u><br>_____<br>_____<br>_____<br>_____<br>_____<br>_____<br>_____ |
| <b>Body Size: Capacity:</b> | Five (5) Cubic Yard Water Level with six (6) Cubic yard Front and Tailgate.  | <u>Describe:</u><br>_____<br>_____  |
| <b>Length:</b>              | 10-Feet.   | <u>Describe:</u><br>_____   |

|                               |   |                                    |
|-------------------------------|---|------------------------------------|
| <b>Width Inside:</b>          | 87-Inches.  | <u>Describe:</u><br>_____<br>_____ |
| <b>Body Head Height:</b>      | 40-inches approx.   | <u>Describe:</u><br>_____<br>_____ |
| <b>Tail Gate Height:</b>      | 32-Inches approx.   | <u>Describe:</u><br>_____<br>_____ |
| <b>Side Height:</b>           | 26 Inches, 4-bend(boxed) top rail, continuous Stainless Steel with dirt shedding top.   | <u>Describe:</u><br>_____<br>_____ |
| <b>Steel Specification:</b>   | 7-Gauge Stainless Steel floor, 10-gauge Stainless Steel sides and ends. With Made od A1011 Steel.   | <u>Describe:</u><br>_____<br>_____ |
| <b>Steel Specification:</b>   | 7-Gauge Stainless Steel floor, 10-gauge Stainless Steel sides and ends. With Made od A1011 Steel.   | <u>Describe:</u><br>_____<br>_____ |
| <b>Longitudinals:</b>         | 9-inch, 7-gauge A1011 Channel Steel.  | <u>Describe:</u><br>_____<br>_____ |
| <b>Corner Posts Rear:</b>     | 2 Each, Approx. 14-Inches, full depth with extra braces with 2 spreader chains, dirt shedding top.  | <u>Describe:</u><br>_____<br>_____ |
| <b>Grab Handles:</b>          | Two (2), one on each side of gate.  | <u>Describe:</u><br>_____<br>_____ |
| <b>Light Reflectors:</b>      | Four (4), one each corner, 2 front and 2 rear, Interstate Commerce Commission approved. Install Conspicuity tape on the rear on the bed. 12-foot minimum                              | <u>Describe:</u><br>_____<br>_____ |
| <b>Control Lever:</b>         | Locking lever pedestal control with 1/4-inch sealed cable.  | <u>Describe:</u><br>_____<br>_____ |
| <b>Banjo Eyes:</b>            | Four (4), 2 Each Side 3/8-inch steel, 4-3/8-inch x 5-inch and extend beyond Rear Post.  | <u>Describe:</u><br>_____<br>_____ |
| <b>Sideboard Gussets:</b>     | Four (4) Each, 6-inches High x 3-inches Wide.   | <u>Describe:</u><br>_____<br>_____ |
| <b>Sideboards Extensions:</b> | Install 2-inch Oak boards tapered from front to rear of bed. Boards to be tapered so that the area from the front of the bed to allow smooth operation of a roll up type tarp system. | <u>Describe:</u><br>_____<br>_____ |
| <b>Tail Gate:</b>             | Double Acting with 2 Vertical Braces and 1 horizontal brace, sloped, dirt shedding at the top   | <u>Describe:</u><br>_____<br>_____ |
| <b>NOTE:</b>                  | When Tailgate is hinged from the bottom, it must not have a gap where material can fall out   | <u>Describe:</u><br>_____<br>_____ |
| <b>Tail Gate Hardware:</b>    | 1-inch. Grease zerk lubricated top hardware; 1-inch lower hardware pivoting on 1 ¼-inch (C1045) shaft, zerk lubricated on both ends.  | <u>Describe:</u><br>_____<br>_____ |

|                                    |  |   |
|------------------------------------|--|---|
| <b>Air Tailgate:</b>               | Air operated tailgate release with in-cab control. The unit shall have an air activated tailgate latch, utilizing a 3-1/2-inch x 8-inch non-tie rod cylinder. The pneumatic cylinder shall be retracted when the latch is closed and shall be located at the rear of the bed to minimize the necessary linkage. The linkage shall be specifically designed to operate with the pneumatic cylinder. | <u>Describe:</u><br>_____<br>_____<br>_____<br>_____<br>_____ |
| <b>Tie Down Rail:</b>              | Full length both sides to be 5/8-inch reinforcing bar, 3-inch high from extreme top outer edge of Rub Rail.  | <u>Describe:</u><br>_____<br>_____                            |
| <b>Ladder</b>                      | Rigid with two (2) 20-inch, four-inch-wide metal grip strut steps attached on the front right-hand side of the body.   | <u>Describe:</u><br>_____<br>_____<br>_____                   |
| <b>Lights:</b>                     | All lights to be LED, plus stop/turn lights flush mounted in the rear corner pillars. Shock resistant, rubber mounted. Factory stop/turn/back up lights installed outside truck frame rails and protected with expanded metal. All lights must meet Federal Motor Vehicle Safety Standards.  | <u>Describe:</u><br>_____<br>_____<br>_____<br>_____          |
| <b>Light Wiring:</b>               | Joints soldered and shrink-wrapped, in a plastic convoluted loom protective covering.  | <u>Describe:</u><br>_____<br>_____                            |
| <b>Mud Flaps:</b>                  | Qty of 2 - One on each side, 24-inch X 30-inch Non-Sail Type. To be without any advertisement. One each mounted on each side to the rear of the tires, Non-Sail type and prevented from becoming entangled in the tires.   | <u>Describe:</u><br>_____<br>_____<br>_____                   |
| <b>Electric Tarp Kit</b>           | Donovan 7000ELD electric tarp kit or approved equal with control box, and a wind deflector- 16-gauge galvanized steel. A 3/16" removeable plate shall be installed over the top of the tarp roll up mechanism to protect it from damage.   | <u>Describe:</u><br>_____<br>_____<br>_____<br>_____          |
| <b>Safety Strut:</b>               | All dump beds must be equipped with safety strut to hold bed in the "UP" position while repairs are being made.  | <u>Describe:</u><br>_____<br>_____                            |
| <b>Spreader Tie Down "D" Rings</b> | Install (4) 1/2-inch dia. "D" Rings on lower rub rail; 2 on each side with one mounted 24" from the front and one mounted 24" from the rear of body. Must have the capability of ratcheting the spreader chains from a standing position on the ground.  | <u>Describe:</u><br>_____<br>_____<br>_____<br>_____          |
| <b>Cab Shield:</b>                 | Full Cab Shield - Full Width of Bed.   | <u>Describe:</u><br>_____<br>_____                            |
| <b>Trailer Tow Pkg.:</b>           | Complete trailer package for pulling air brake trailers. To include air lines plumbed to rear of frame from the factory source (To be supplied by the truck manufacturer). Furnish and install glad hands and 7-way electrical connector at rear of frame ready to use with a 6 to 7-way   | <u>Describe:</u><br>_____<br>_____<br>_____<br>_____          |

|  |  |  |
|--|--|--|
|  | adaptor. Air couplers and electrical connections are to be mounted as high as possible in the hinge area and plumbed in such a way as to not interfere with dumping of the bed or sand spreader operation and to avoid contact when pulling trailers.  | _____<br>_____<br>_____<br>_____                                       |
| <b>Pintle Hitch:</b>                     | Reinforced trailer hitch mounted on a 5/8-inch plate, gusseted, with a 90,000 lb. air pintle hitch, Holland PH210 or equal. Trailer safety rings are Crosby weldless links per Item 21 of this IFB to match capacity of hitch. Air lines to have quick disconnect fittings behind air operated pintle hitch so hitch may be removed during certain operations of the dump truck such as spreader operations.                                 | <u>Describe:</u><br>_____<br>_____<br>_____<br>_____<br>_____          |
| <b>Strobes, Front &amp; Rear:</b>        | Furnish and install LED strobes on each side in rear corner pillars and front grill area of truck per Item 5, options 5K and 5L of this IFB.   | <u>Describe:</u><br>_____<br>_____                                     |
| <b>Warranty:</b>                         | Body manufacturer shall provide a written 5-year warranty covering repair or replacement of the body, hoist and air cylinder for defective material and/or workmanship. Warranty shall include all freight and labor for repairs or replacement. Warranty shall also include adherence of primer to all metal surfaces not including inside or understructure of dump bodies. The manufacturer's warranty <u>must</u> be submitted with Bid. | <u>Describe:</u><br>_____<br>_____<br>_____<br>_____<br>_____<br>_____ |
| <b>Note:</b>                             | Warranty labor and parts replacement must be handled by an in-state authorized dealer, who can provide immediate replacement without charge or delay. "See Specification Header at beginning of Bid Specifications".   | <u>Describe:</u><br>_____<br>_____<br>_____<br>_____                   |
| <b>Hydraulic Hoist, Frame, Pump:</b>     | Minimum of a Class 50  | <u>Describe:</u><br>_____  |
| <b>Body Hoist:</b>                       | Scissor Type.  | <u>Describe:</u><br>_____  |
| <b>Dumping Angle:</b>                    | 50 Degrees.  | <u>Describe:</u><br>_____  |
| <b>Hydraulic Pump:</b>                   | Gear type 6 GPM @ 1000 RPM & 2250 PSI. Pump to be mounted directly on PTO.   | <u>Describe:</u><br>_____<br>_____                                     |
| <b>Shaft Bearings:</b>                   | Roller Bearing, Antifriction   | <u>Describe:</u><br>_____<br>_____                                     |
| <b>Oil Reservoir:</b>                    | Capacity 10 gallons, approx., with filtered return line, shut off valve on suction port.   | <u>Describe:</u><br>_____<br>_____                                     |
| <b>Low Hydraulic Fluid Warning Light</b> | Must install in the cab a Low Hydraulic Fluid Warning Light within easy view of driver.  | <u>Describe:</u><br>_____<br>_____                                     |

|  |  |   |
|--|--|---|
| <p><b>Hoist to Be:</b></p>                     | <p>Class 50 Min., power up/power down. National Truck Equipment Association approved.</p>  | <p><u>Describe:</u></p> <hr/> <hr/>   |
| <p><b>Controls:</b></p>                        | <p>Locking lever pedestal controls with <u>Body Up</u> audio and visual alarm. A locking device to lock controls in neutral position shall be provided. Control and valve connected with a 1/4-inch sealed cable.</p>  | <p><u>Describe:</u></p> <hr/> <hr/>   |
| <p><b>Power Take-Off:</b></p>                  | <p>Direct driven from transmission to hydraulic pump. PTO to have enabler capability (i.e. "Hot Shift" Type) with electronic "overspeed protection" to prevent PTO from turning at more RPM than system is designed to handle. Must be geared to allow continuous operation at 0-30 MPH. Electronic dash mounted controls with engagement light, no levers or cables, must be able to shift PTO while truck is in motion 15 to 20 MPH.</p>   | <p><u>Describe:</u></p> <hr/> <hr/> <hr/> <hr/>   |
| <p><b>Over-Speed Protection for P.T.O.</b></p> | <p>Fully adjustable from 300 to 3000 RPM.</p>  | <p><u>Describe:</u></p> <hr/>   |
| <p><b>Options</b></p>                          | <ol style="list-style-type: none"> <li>1. <u>Central Hydraulic System with Quick Disconnect:</u><br/>Muncie MP2 central hydraulic system or acceptable equal capable of operating the dump body hoist, snow plow up/down/left/right and sand spreader spinner and conveyor. (see specification below) **<br/>Air controls option for feathering the bed not required if installing a Central Hydraulic System with Quick Disconnect.</li> <li>2. <u>Spread Apron:</u><br/>12-inch Spread Apron, 10 ga. Stainless Steel.</li> <li>3. <u>Ball Hitch:</u><br/>Reinforced trailer hitch mounted on a 5/8-inch plate, gusseted, with a Buyers or Kernis K300 2 5/16-inch ball hitch rated at 16,000 LB. Trailer safety rings are Crosby weldless links per Item 21 to match capacity of hitch.</li> <li>4. <u>Toolbox:</u><br/>Frame mounted toolbox, 36-inches x 18-inches x18-inches, Rawson-Koenig H361818 or equal.</li> <li>5. <u>Sideboards:</u> <ol style="list-style-type: none"> <li>A. In place of the 2" Oak Boards, install Rumbar type material 2-inch boards tapered from front to rear of bed so that the area from the front of the bed to the rear to allow smooth operation of a roll up type tarp system.</li> <li>B. In place of the 2" Oak Boards, install 10-gauge "C" channel reinforced every 3-feet, bolted in place tapered from front to rear of bed to allow smooth operation of a roll up type tarp system.</li> </ol> </li> <li>6. <u>Air Controls:</u><br/>Air operated controls for raising and lowering dump bed. Controls shall be of the type to enable operator to feather the bed down.</li> </ol> | <p><u>Describe:</u></p> <p>1</p> <hr/> <hr/> <hr/> <hr/> <hr/> <hr/> <hr/> <hr/> <hr/> <hr/> <p>2</p> <hr/> <hr/> <hr/> <hr/> <hr/> <hr/> <hr/> <hr/> <hr/> <hr/> <p>3</p> <hr/> <hr/> <hr/> <hr/> <hr/> <hr/> <hr/> <hr/> <hr/> <hr/> <p>4</p> <hr/> <hr/> <hr/> <hr/> <hr/> <hr/> <hr/> <hr/> <hr/> <hr/> <p>5</p> <p>A</p> <hr/> <hr/> <hr/> <hr/> <hr/> <hr/> <hr/> <hr/> <hr/> <hr/> <p>B</p> <hr/> <hr/> <hr/> <hr/> <hr/> <hr/> <hr/> <hr/> <hr/> <hr/> <p>6</p> <hr/> <hr/> <hr/> <hr/> <hr/> <hr/> <hr/> <hr/> <hr/> <hr/> |

|  |  |                   |
|--|--|-------------------|
|  | Note: This system not required if installing a Central Hydraulic System with Quick Disconnect. | <hr/> <hr/> <hr/> |
|--|--|-------------------|

**TAILLIGHTS:** Taillights of vehicle are to be mounted on the outside of the truck frame. Taillights shall be installed within a protected bracket to prevent them from being knocked off accidentally. Lens should be protected with expanded metal.

**MOUNTING INSTRUCTIONS:** The front mounting brackets on each side of the frame shall be drilled and bolted, not welded to the truck frame. The hydraulic pump shall be direct mounted to the Power take off. The rear end of the truck frame to be cut the least amount to allow the bed to reach maximum dumping position. The truck frame shall be cut at a right angle or square cut rather than tapered. (The trimmed material must be left in the truck bed.)

The following requirements will be necessary if there is no safeguard to prevent the bed from being raised too high or beyond the return point of the hydraulic hoist cylinders:  
 Safety bed stop blocks of sufficient thickness to provide this protection must be mounted behind the bed hinges between the bed and truck frame.

**NOTE:** Bed Seller must NOT remove identification plates or numbers on the truck. This especially applies to the truck transmission when power take off is installed. If, during installations, it becomes necessary to remove these plates or cover these numbers, then these numbers and/or plates must be replaced in a visible location.

**ELECTRICAL WIRING:** Wiring to be in loom and properly secured to frame to prevent sagging. Upon completion of installation all connections, splices and wiring to be protected by all-weather insulation. This insulation material to be enough quality to insure a life period of five (5) years.

**\*POWER TAKE OFF:** Must be the latest current model installed and/or adapted to fit the transmission. Mounting bolts or screws must provide adequate self-locking and sealing to insure against oil leaks and must keep housing firmly attached to transmission.

**PAINT:** All exposed metal shall be primed and painted. The bed shall be sprayed or dipped with a protective metal primer, then be painted Factory White to match vehicle. The inside of the bed shall be painted at least one foot down the sides. Paint load space of the body from the top down approximately 12-inch Toolboxes, reservoirs and hitches will be painted black.

**PARTS:** Bidder shall furnish upon request a list of established manufacturer's authorized locations where an adequate stock of current parts and service are available.

**MANUALS AND PARTS BOOKS:** Seller shall furnish two (2) operator's instruction manuals for each unit, in addition, two (2) parts books and two (2) illustrated repair manuals shall be furnished to each Division purchasing one or more bodies. The operators, parts and service manuals may be on CD rom.

**SERVICE POLICY:** Manufacturer's standard service policy shall be furnished, complete and unaltered, with each unit delivered. Manufacturer shall be responsible that satisfactory services (by other than the dealer selling unit) are rendered upon presentation of proper service policy service policy papers.

**\*\*Hydraulic Central Control System for Snow and Ice Equipment:** Install a Muncie MP2 central hydraulic system or acceptable equal capable of operating the dump body hoist, snow plow up/down/left/right and sand spreader spinner and conveyor.

The sand spreader system shall contain a 3/4-inch pressure line for the spinner and a 3/4-inch pressure line for the conveyor and a single 1-inch return line. These lines will be hard piped from the hoist area to the rear of the truck. The spinner quick connect shall be an Eaton #5602-12-12S or acceptable equal. The conveyor quick connect shall be an Eaton #5601-12-12S or acceptable equal. The return quick connect shall be an Eaton #5602-16-16S or acceptable equal. All quick connects must be compatible with existing quick connects of same size being utilized in



the current fleet of trucks so all sand spreaders units are compatible with any truck utilized. All quick connects are to be mounted on the rear curbside of the dump body approximately 10-inches from the rear (contact a City of Tulsa representative for an exact location). All quick connects to have a protective cover. These quick connects shall be mounted so they will not interfere with dumping of the bed or with use of the Pintle Hitch.

The Hydraulic Valving shall be as follows. The circuit design shall include Load-Sensing communication from all valves. The valves shall be solenoid operated carriage style with a common manifold and rated IP69. There shall be a flow priority to insure operation of the cylinder functions whenever the spreader is operating, and pump flow is critically low. All cylinders shall have proportional flow control on the power sequence to afford cylinder speed control. Pressure relief valves shall have an independent stem adjustable pressure protection included for the manifold inlet, the spreader, the downside of all double acting cylinders and plow angle cylinders. The plow lift valves shall be capable of four- way control and have a flow capacity of 15 gallons per minute (GPM). The raise side of the circuit shall be rated for zero leakage. The plow angle valves shall be capable of four- way control and have a flow capacity of 15 GPM. Load Locking check valves) or Motor Spool design) shall be included as required to support the angling mechanism used. The dump hoist valves shall have a four -way control and have a flow capacity of 30 GPM. Counterbalance control valves shall be included. The spreader proportional control valves for the auger, conveyor, and spinner motors shall have flow capacities of 15/7 GPM respectively. These valves shall be pressure compensated and parallel in their circuit architecture.

The System Controls commands to the system valves shall be digitally encoded and sent over the vehicles electrical system using only a 12-volt DC and ground connection at each end of the system.

The valve driver modules shall be housed in Deutsch boxes employ Deutsch connectors at solenoids or acceptable equal giving IP69 environmental rating. The valve driver modules shall be equipped with current sensing control to offset thermal changes in solenoid performance and to detect open or short circuit conditions and protect against the latter by automatic interruption of current to the shorted output.

Cylinder momentary push button switches will provide on-off style control of the plow and dump body operations. Program settings will provide effective and independent flow trims for plow up-down, plow angle and dump up-down.

A two-axis cylinder proportional joystick with dead man switch and pushbutton selection of equipment shall be provided. The joystick shall employ dual redundant hall-effect mechanisms, eliminating the wear of potentiometer or other contact mechanisms. In the event of failure of one hall-effect output a program adjustment to system controller will allow selection of the alternate channel. The same controller will also provide electronic adjustment of one degree from center for operation, minimum valve drive at minimum joystick deflection, and maximum valve drive at maximum joystick deflection. Adjustments for degrees from center operation and the minimum valve drive at minimum joystick deflection will be independent for the plow and dump. The joystick shall plug to the control panel as it's only connection point. Connection of the joystick will render the pushbutton cylinder controls inoperable. Conversely, disconnection of the joystick will reactivate the pushbutton controls. Selection of the equipment function by pushbuttons on the head of the joystick will illuminate an equipment identity label on the control panel. No operation of the joystick can take place without holding the dead man switch.

The spreader controls modes of operation shall provide a selectable automatic and manual control. There shall be a Blast operation with programmable selection of level and time. A Pause operation shall be available to momentarily disable the spreader operation. A feedback sensor shall not be required to achieve accurate and consistent operation of the spreader functions.

High brightness LED numerical displays will be used to indicate one of 11 reference controls positions for the spinner and auger (manual mode). In Auto operation the auger display will indicate "pounds per mile" if the system has been calibrated for such. The system shall display fault occurrences of shorted or open outputs at the valves with indication of which circuit is responsible.

All controls will be mounted in the truck cab. The joystick shall be mounted on a pedestal style mechanism beside the driver at a level and location that is comfortable to operate, allowing the driver to operate at a glance without taking his eyes completely off the road. The Control display panel shall be mounted in the dash area and at a level easily viewed by the driver.

An integral valve/tank enclosure assembly shall be mounted to the frame rail of the vehicle. The reservoir and dry compartment shall be made of 7-gauge mild powder coated steel and the lid assembly shall be made of 10-gauge mild powder coated steel painted black to match the frame rails.

The bottom portion of the valve/tank integral design shall house a minimum of 35 gallons of hydraulic oil with temperature/sight gauge mounted on the front face. The reservoir shall be properly baffled with a drain plug in the bottom and provision in the top for an in-tank, glass type return line filter. There shall also be a fill tube vented cap assembly that will also serve as a clean out port. The filter will be a minimum of 10 micron and the element shall be easily removed for replacement.

The top portion of the valve/tank assembly will be dry with a rubber seal that will provide protection when the lid assembly is in place. This area will house the tube/vented cap, return line in-tank filter, the solenoid control valve manifold, and the PLC electronic command modules.

The solenoid control manifold valve will mount in the enclosure against the back wall allowing for all cylinder and spreader hose connections to be mounted directly to this assembly. The back of the manifold assembly will be bolted to the back wall in a way to prevent outside contamination and to allow for the O ring fittings for hose connections to the direct entry eliminating the need for internal cylinder and spreader hose plumbing. The valve/tank assembly shall be narrow or stepped from the frame of the vehicle to allow for ample room for installation and servicing of the hoses.

The PLC modules will be contained to the back wall of the enclosure and will allow for easy servicing. The wiring from the manifold cartridge solenoids will plug into these two modules and the power, ground, and ground speed control conductors will exit the enclosure with a strain relief sealed connector.

The lid will set on a perimeter gasket and will be retained with four over-center chrome latches for easy access and removal. The entire valve/tank enclosure will be mounted to the frame in a cradle fabricated by the installer to properly support the assembly.

**Item 30: 10 Cubic Yard Steel Dump Body – 120-inchCA**

| Item                        | Specifications (Minimum)  | Bidder's Proposal   |
|-----------------------------|---|---|
| <b>General Description:</b> | This Specification shall provide for new, the latest current production model. <u>Western/Crossmemberless Style</u> steel hydraulic dump beds, complete with manufacturer's standard equipment and accessories, fully serviced ready to operate. To include manufacturer's certificate. (Warranty shall be the standard for the industry as offered to the public.) This body shall be equipment to meet all Federal and State of Oklahoma Safety Standards and requirement. No dealer advertisement shall be affixed to the bed. | Describe:<br>_____<br>_____<br>_____<br>_____<br>_____<br>_____<br>_____<br>_____ |
| <b>Body Size: Capacity:</b> | 10-Cubic yards. Water Level, 13-Cubic yards. with sideboard extensions.   | Describe:<br>_____<br>_____   |
| <b>Length:</b>              | 14-Feet.  | Describe:<br>_____<br>_____   |
| <b>Width Inside:</b>        | 87-Inches.  | Describe:<br>_____<br>_____   |



|                            |   |  |
|----------------------------|---|--|
| <b>Head Height:</b>        | 60-Inches.  | <u>Describe:</u><br>_____                            |
| <b>Tail Gate Height:</b>   | 42-Inches.  | <u>Describe:</u><br>_____                            |
| <b>Side Height:</b>        | 34-Inches, 4-bend (boxed) top rail, continuous steel with dirt shedding top   | <u>Describe:</u><br>_____                            |
| <b>Steel Thickness:</b>    | 7-Gauge floor, 10-gauge sides and ends. With Made od A1011 Steel.   | <u>Describe:</u><br>_____<br>_____                   |
| <b>Floor:</b>              | Approx. 8-inch Radius floor to sidewall for easy cleanout.  | <u>Describe:</u><br>_____<br>_____                   |
| <b>Longitudinals:</b>      | 9-inch, 7-gauge, A1011 channel steel.   | <u>Describe:</u><br>_____                            |
| <b>Corner Posts Rear:</b>  | 2 Each, Approx. 12 3/4-Inches, full depth with extra braces with 2 tailgate chains, dirt shedding top.  | <u>Describe:</u><br>_____<br>_____                   |
| <b>Corner Posts Front:</b> | 2 each full depth, Approx. 8-inch wide with 4-inch radius, dirt shedding top.   | <u>Describe:</u><br>_____<br>_____                   |
| <b>Tail Gate Chains:</b>   | 2 each.   | <u>Describe:</u><br>_____                            |
| <b>Grab Handles:</b>       | Two (2), one on each side of gate.  | <u>Describe:</u><br>_____                            |
| <b>Rub Rails:</b>          | Full length sloping.  | <u>Describe:</u><br>_____                            |
| <b>Clearance Lights:</b>   | Federal Motor Vehicle Safety Standard, LED clearance lights plus LED Stop/turn lights flush mounted in the rear corner pillars, shock resistant rubber mounted. Wiring-joints soldered and shrink wrapped with loom covering. | <u>Describe:</u><br>_____<br>_____<br>_____<br>_____ |
| <b>Light Wiring:</b>       | Joints soldered and shrink-wrapped, in a plastic convoluted loom protective covering.   | <u>Describe:</u><br>_____<br>_____                   |
| <b>Base Weight:</b>        | Show base weight of body (without hoist & accessories).   | <u>Describe:</u><br>_____<br>_____                   |
| <b>Reflectors:</b>         | Six (6), 2 each side, 2 rear mounted on 3-inch dia. end gate. Must be ICC approved, Federal #108, Lighting to apply. <b>NOTE:</b> These reflectors must be housed type with screw or bolt type mounting, stick-on type is not | <u>Describe:</u><br>_____<br>_____<br>_____<br>_____ |

|                             |  |   |
|-----------------------------|--|---|
|                             | acceptable. Install Conspicuity tape on the rear on the bed. 12-foot minimum   | _____<br>_____  |
| <b>Tail Gate:</b>           | Double Acting with fully welded 6 panel-type bracing and offset hardware.  | <u>Describe:</u><br>_____<br>_____  |
| <b>Note:</b>                | When Tailgate is hinged from the bottom, it must not have a gap where material can fall out  | <u>Describe:</u><br>_____<br>_____  |
| <b>Banjo Eyes:</b>          | 4, 2 Each Side 3/8-inch steel, 4-3/8-inches x 5-inches and extend beyond Rear Post.  | <u>Describe:</u><br>_____<br>_____  |
| <b>Sideboard Braces:</b>    | 5 Inch Box Type  | <u>Describe:</u><br>_____<br>_____  |
| <b>NOTE:</b>                | All channel Iron used in mounting these extensions must be assembled so the flanges are turned to the inside of the bed. This is to eliminate edges which might collect materials, on the outside of the bed.  | <u>Describe:</u><br>_____<br>_____<br>_____<br>_____  |
| <b>Brackets:</b>            | 2, 30-inches x 5-inches, 1/8-inchthick Steel.<br>(See Manufacturer's Instructions)   | <u>Describe:</u><br>_____<br>_____  |
| <b>Mud Flaps:</b>           | 2 - One on each side, 24-inches X 30-inches Non-Sail Type. To be without any advertisement. One each mounted on each side at the rear of the duals, Non-Sail type and prevented from becoming entangled in the tires.  | <u>Describe:</u><br>_____<br>_____<br>_____<br>_____  |
| <b>Tail Gate Hardware:</b>  | Upper offset Tailgate Hinges shall be of plate steel. Lower tailgate pins shall be 1-1/4-inches diameter minimum. Lower body hardware shall be of the overhead type hooks and retain the 1-1/4-inch Pins in supports on each side of the hook.   | <u>Describe:</u><br>_____<br>_____<br>_____<br>_____  |
| <b>Note:</b>                | When Tailgate is hinged from the bottom, it must not have a gap where material can fall out  | <u>Describe:</u><br>_____<br>_____  |
| <b>Folding Ladder</b>       | Qty of Two, 20-inch, four (4) inch wide metal grip strut steps attached on the front right- hand side of the body. Install a slide out, (2) rung ladder, mounted under the body just below the steps. The slide out ladder shall be on a hinged mechanism that has a positive latch system and will be locked in storage mode or when retracted out will hinge down and be locked in a stable configuration for safe utilization and accessible from the ground. The steps and the 2 rung ladder will allow access from the ground to the top of the body. | <u>Describe:</u><br>_____<br>_____<br>_____<br>_____<br>_____<br>_____<br>_____<br>_____<br>_____ |
| <b>Tarp Tie Down Rails:</b> | Full length both sides to be 5/8-inch reinforcing bar, 3-inches high from extreme top outer edge of Rub Rail.  | <u>Describe:</u><br>_____<br>_____  |

|  |  |   |
|--|--|---|
| <b>Mounting Height:</b>                | Not to exceed 12 3/8-inches from Top of Truck frame to floor of body.  | <u>Describe:</u><br>_____<br>_____  |
| <b>Cab Shield:</b>                     | Full Cab Shield - Full Width of Bed.   | <u>Describe:</u><br>_____   |
| <b>Safety Strut:</b>                   | All dump beds must be equipped with Safety Strut to hold bed in the "UP" position while repairs are being made. (ONE EACH SIDE).   | <u>Describe:</u><br>_____<br>_____  |
| <b>Spreader Tie Down<br/>"D" Rings</b> | Install four (4) 1/2-inch dia. "D" Rings on lower rub rail; Two (2) on each side with one mounted 24-inches from the front and one mounted 24-inches from the rear of body. Must have the capability of ratcheting the spreader chains from a standing position on the ground.   | <u>Describe:</u><br>_____<br>_____<br>_____<br>_____                            |
| <b>Trailer Tow Pkg.:</b>               | Complete trailer package for pulling air brake trailers. To include air lines plumbed to rear of frame from the factory source (To be supplied by the truck manufacturer). Furnish and install glad hands and 7-way electrical connector at rear of frame ready to use with a 6 to 7-way adaptor. Air couplers and electrical connections are to be mounted as high as possible in the hinge area and plumbed in such a way as to not interfere with dumping of the bed or sand spreader operation and to avoid contact when pulling trailers. | <u>Describe:</u><br>_____<br>_____<br>_____<br>_____<br>_____<br>_____<br>_____ |
| <b>Pintle Hitch:</b>                   | Reinforced trailer hitch mounted on a 5/8-inch plate, gusseted, with a 90,000 lb. air pintle hitch, Holland PH210 or equal. Trailer safety rings are Crosby weldless links per Item 21 of this IFB to match capacity of hitch.<br>Air lines to have quick disconnect fittings behind air operated pintle hitch so hitch may be removed during certain operations of the dump truck such as spreader operations.  | <u>Describe:</u><br>_____<br>_____<br>_____<br>_____<br>_____<br>_____          |
| <b>Strobes, Front &amp; Rear:</b>      | Furnish and install LED strobes on each side in rear corner pillars and front grill area of truck per Item 5, options 5K and 5L of this IFB.   | <u>Describe:</u><br>_____<br>_____  |
| <b>Electric Tarp Kit</b>               | Donovan 7000ELD electric tarp kit or approved equal with control box. A wind deflector: 16-gauge galvanized steel. A 3/16-inch removeable plate shall be installed over the top of the tarp roll up mechanism to protect it from damage.   | <u>Describe:</u><br>_____<br>_____<br>_____                                     |
| <b>Warranty:</b>                       | Body manufacturer shall provide a written 5-year warranty covering repair or replacement of the body, hoist and air cylinder for defective material and/or workmanship. Warranty shall include all freight and labor for repairs or replacement. Warranty shall also   | <u>Describe:</u><br>_____<br>_____<br>_____                                     |

|   |   |  |
|---|---|--|
|   | include adherence of primer to all metal surfaces not including inside or understructure of dump bodies. The manufacturer's warranty <u>must</u> be submitted with Bid.   | _____<br>_____<br>_____                              |
| <b>Note:</b>                                      | Warranty labor and parts replacement must be handled by an in-state authorized dealer, who can provide immediate replacement without charge or delay. "See Specification Header at beginning of Bid Specifications".  | <u>Describe:</u><br>_____<br>_____<br>_____          |
| <b>Hydraulic Hoist, Pump &amp; Control Valve:</b> | Class 110   | <u>Describe:</u><br>_____                            |
| <b>Cylinder:</b>                                  | Show inside diameter & piston diameter and stroke _____" 1st active sleeve, _____" 2nd, _____" 3rd, _____" and base tube _____" stroke, single acting, self-adjusting V-type packing interior guide bushing – chrome plated cylinder.   | <u>Describe:</u><br>_____<br>_____<br>_____          |
| <b>Hoist Capacity</b>                             | 37-Tons.  | <u>Describe:</u><br>_____                            |
| <b>Dump Angle:</b>                                | 50 Degrees Maximum.   | <u>Describe:</u><br>_____                            |
| <b>Auto Bleed System:</b>                         | An internal spring assisted device to automatically remove air from the cylinder and hydraulic lines whenever the cylinder is extended and retracted. The device shall not bleed air directly to atmosphere and shall use hydraulic fluid to push air out of the cylinder and back to tank. | <u>Describe:</u><br>_____<br>_____<br>_____<br>_____ |
| <b>Oil Reservoir:</b>                             | Capacity: 28-gallons, shut off valve on the suction port Reservoir located outside of frame.  | <u>Describe:</u><br>_____<br>_____                   |
| <b>Low Hydraulic Fluid Warning Light</b>          | Must install in the cab a Low Hydraulic Fluid Warning Light within easy view of driver.   | <u>Describe:</u><br>_____<br>_____                   |
| <b>Rear Pivot Hinges</b>                          | Double shear type - 2 hinge pins 1-3/4-inches x 8-inches.   | <u>Describe:</u><br>_____<br>_____                   |
| <b>Hydraulic Pump</b>                             | 15-GPM @ 2000 PSI @ 1000 RPM. Pump to be mounted directly on PTO.   | <u>Describe:</u><br>_____<br>_____                   |
| <b>Relief Valve:</b>                              | Built into valve.   | <u>Describe:</u><br>_____                            |
| <b>Shaft Bearings:</b>                            | Roller Bearings Standard.   | <u>Describe:</u><br>_____                            |
| <b>Control Valve:</b>                             | 4 Position (raised, hold, feather, and lower) direct mounted on the reservoir.  | <u>Describe:</u><br>_____<br>_____                   |

|   |   |  |
|---|---|--|
| <p><b>Controls:</b></p>                     | <p>Locking lever pedestal control with <u>Body Up</u> audio and visual alarm. A locking device to lock controls in neutral position shall be provided. Connect lever and valve with a 1/4-inch sealed cable. Valves to be Gresen model V-20.</p>  | <p><u>Describe:</u></p> <p>_____</p> <p>_____</p> <p>_____</p> <p>_____</p>  |
| <p><b>Power Take-Off:</b></p>               | <p>Direct driven from transmission to hydraulic pump. PTO to have enabler capability (i.e. "Hot Shift" Type) with electronic "overspeed protection" to prevent PTO from turning at more RPM than system is designed to handle. Must be geared to allow continuous operation at 0-30 MPH. Electronic dash mounted controls with engagement light, no levers or cables, must be able to shift PTO while truck is in motion 15 to 20 MPH.</p>  | <p><u>Describe:</u></p> <p>_____</p> <p>_____</p> <p>_____</p> <p>_____</p>  |
| <p><b>Over Speed Protection for PTO</b></p> | <p>Fully adjustable from 300 to 3000 RPM</p>  | <p><u>Describe:</u></p> <p>_____</p>   |
| <p><b>Options</b></p>                       | <ol style="list-style-type: none"> <li>1. <u>Central Hydraulic System with Quick Disconnect:</u><br/>Muncie MP2 central hydraulic system or acceptable equal capable of operating the dump body hoist, snow plow up/down/left/right and sand spreader spinner and conveyor. (see specification below).</li> <li>2. <u>Spread Apron:</u><br/>12-inch apron, 10-gauge steel.</li> <li>3. <u>Ball Hitch:</u><br/>Reinforced trailer hitch mounted on a 5/8-inch plate, gusseted, with a Buyers or Kernis K300 2 5/16-inch ball hitch rated at 16,000 LB. Trailer safety rings are Crosby weldless links per Item 21 to match capacity of hitch.</li> <li>4. <u>Toolbox:</u> Frame mounted toolbox, 36-inches x 18-inches x 18-inches, Rawson-Koenig H361818 or equal.</li> <li>5. <u>Sideboards:</u> <ol style="list-style-type: none"> <li>A. In place of the 2-inch Oak Boards, install Rumber type material 2-inch boards tapered from front to rear of bed so that the area from the front of the bed to the rear to allow smooth operation of a roll up type tarp system.</li> <li>B. In place of the 2-inch Oak Boards, install 10-gauge "C" channel reinforced every 3-feet bolted in place tapered from front to rear of bed to allow smooth operation of a roll up type tarp system.</li> </ol> </li> <li>6. <u>Air Controls:</u><br/>Air operated controls for raising and lowering dump bed. Controls shall be of the type to enable operator to feather the bed down.<br/>** This system not required if installing a Central Hydraulic System with Quick Disconnect.</li> <li>7. <u>Flooring:</u><br/>1/4-inch-thick steel floor in lieu of 7-gauge.</li> </ol> | <p><u>Describe:</u></p> <p>1 _____</p> <p>_____</p> <p>_____</p> <p>_____</p> <p>_____</p> <p>2 _____</p> <p>_____</p> <p>_____</p> <p>_____</p> <p>_____</p> <p>3 _____</p> <p>_____</p> <p>_____</p> <p>_____</p> <p>_____</p> <p>4 _____</p> <p>_____</p> <p>_____</p> <p>_____</p> <p>_____</p> <p>5 _____</p> <p>A _____</p> <p>_____</p> <p>_____</p> <p>_____</p> <p>_____</p> <p>B _____</p> <p>_____</p> <p>_____</p> <p>_____</p> <p>_____</p> <p>6 _____</p> <p>_____</p> <p>_____</p> <p>_____</p> <p>_____</p> <p>7 _____</p> <p>_____</p> <p>_____</p> |

|  |   |                                    |
|--|---|------------------------------------|
|  | <p>8. <u>Step:</u><br/>Qty of two (2), 20-inch steps, 4-inches wide metal grip strut located on the right front side corner of the body. No folding ladder.</p> | <p>8 _____<br/>_____<br/>_____</p> |
|--|---|------------------------------------|

**Hydraulic Central Control System for Snow and Ice Equipment:**

Install a Muncie MP2 central hydraulic system or acceptable equal capable of operating the dump body hoist, snow plow up/down/left/right and sand spreader spinner and conveyor.

The sand spreader system shall contain a 3/4" pressure line for the spinner and a 3/4" pressure line for the conveyor and a single 1" return line. These lines will be hard piped from the hoist area to the rear of the truck. The spinner quick connect shall be an Eaton #5602-12-12S or acceptable equal. The conveyor quick connect shall be an Eaton #5601-12-12S or acceptable equal. The return quick connect shall be an Eaton #5602-16-16S or acceptable equal. All quick connects must be compatible with existing quick connects of same size being utilized in the current fleet of trucks so all sand spreaders units are compatible with any truck utilized. All quick connects are to be mounted on the rear curbside of the dump body approximately 10" from the rear (contact a City of Tulsa representative for an exact location. All quick connects to have a protective cover. These quick connects shall be mounted so they will not interfere with dumping of the bed or with use of the Pintle Hitch.

The Hydraulic Valving shall be as follows. The circuit design shall include Load-Sensing communication from all valves. The valves shall be solenoid operated carriage style with a common manifold and rated IP69. There shall be a flow priority to insure operation of the cylinder functions whenever the spreader is operating, and pump flow is critically low. All cylinders shall have proportional flow control on the power sequence to afford cylinder speed control. Pressure relief valves shall have an independent stem adjustable pressure protection included for the manifold inlet, the spreader, the downside of all double acting cylinders and plow angle cylinders. The plow lift valves shall be capable of four-way control and have a flow capacity of 15 GPM. The raise side of the circuit shall be rated for zero leakage. The plow angle valves shall be capable of four-way control and have a flow capacity of 15 GPM. Load Locking check valves) or Motor Spool design) shall be included as required to support the angling mechanism used. The dump hoist valves shall have a four-way control and have a flow capacity of 30 GPM.

Counterbalance control valves shall be included. The spreader proportional control valves for the auger, conveyor, and spinner motors shall have flow capacities of 15/7 GPM respectively. These valves shall be pressure compensated and parallel in their circuit architecture.

The System Controls commands to the system valves shall be digitally encoded and sent over the vehicles electrical system using only a 12-volt DC and ground connection at each end of the system.

The valve driver modules shall be housed in Deutsch boxes employ Deutsch connectors at solenoids or acceptable equal giving IP69 environmental rating. The valve driver modules shall be equipped with current sensing control to offset thermal changes in solenoid performance and to detect open or short circuit conditions and protect against the latter by automatic interruption of current to the shorted output.

Cylinder momentary push button switches will provide on-off style control of the plow and dump body operations. Program settings will provide effective and independent flow trims for plow up-down, plow angle and dump up-down.

A two-axis cylinder proportional joystick with dead man switch and pushbutton selection of equipment shall be provided. The joystick shall employ dual redundant hall-effect mechanisms, eliminating the wear of potentiometer or other contact mechanisms. In the event of failure of one hall-effect output a program adjustment to system controller will allow selection of the alternate channel. The same controller will also provide electronic adjustment of one degree from center for operation, minimum valve drive at minimum joystick deflection, and maximum valve drive at maximum joystick deflection. Adjustments for degrees from center operation and the minimum valve drive at minimum joystick deflection will be independent for the plow and dump. The joystick shall plug to the control panel as its only connection point. Connection of the joystick will render the pushbutton cylinder controls inoperable. Conversely, disconnection of the joystick will reactivate the pushbutton controls. Selection of the equipment function by pushbuttons on the head of the joystick will illuminate an equipment identity label on the control panel. No operation of the joystick can take place without holding the dead man switch.



The spreader controls modes of operation shall provide a selectable automatic and manual control. There shall be a Blast operation with programmable selection of level and time. A Pause operation shall be available to momentarily disable the spreader operation.

A feedback sensor shall not be required to achieve accurate and consistent operation of the spreader functions. High brightness LED numerical displays will be used to indicate one of 11 reference controls positions for the spinner and auger (manual mode). In Auto operation the auger display will indicate “pounds per mile” if the system has been calibrated for such.

The system shall display fault occurrences of shorted or open outputs at the valves with indication of which circuit is responsible.

All controls will be mounted in the truck cab. The joystick shall be mounted on a pedestal style mechanism beside the driver at a level and location that is comfortable to operate, allowing the driver to operate at a glance without taking his eyes completely off the road. The Control display panel shall be mounted in the dash area and at a level easily viewed by the driver.

An integral valve/tank enclosure assembly shall be mounted to the frame rail of the vehicle. The reservoir and dry compartment shall be made of 7-gauge mild powder coated steel and the lid assembly shall be made of 10-gauge mild powder coated steel painted black to match the frame rails.

The bottom portion of the valve/tank integral design shall house a minimum of 35 gallons of hydraulic oil with temperature/sight gauge mounted on the front face. The reservoir shall be properly baffled with a drain plug in the bottom and provision in the top for an in-tank, glass type return line filter. There shall also be a fill tube vented cap assembly that will also serve as a clean out port. The filter will be a minimum of 10 micron and the element shall be easily removed for replacement.

The top portion of the valve/tank assembly will be dry with a rubber seal that will provide protection when the lid assembly is in place. This area will house the tube/vented cap, return line in-tank filter, the solenoid control valve manifold, and the PLC electronic command modules.

The solenoid control manifold valve will mount in the enclosure against the back wall allowing for all cylinder and spreader hose connections to be mounted directly to this assembly. The back of the manifold assembly will be bolted to the back wall in a way to prevent outside contamination and to allow for the O ring fittings for hose connections to the direct entry eliminating the need for internal cylinder and spreader hose plumbing. The valve/tank assembly shall be narrow or stepped from the frame of the vehicle to allow for ample room for installation and servicing of the hoses.

The PLC modules will be contained to the back wall of the enclosure and will allow for easy servicing. The wiring from the manifold cartridge solenoids will plug into these two modules and the power, ground, and ground speed control conductors will exit the enclosure with a strain relief sealed connector.

The lid will set on a perimeter gasket and will be retained with four over-center chrome latches for easy access and removal. The entire valve/tank enclosure will be mounted to the frame in a cradle fabricated by the installer to properly support the assembly.

**ITEM 31: 13 Cubic Yard Steel Dump Body – 126-inch CA**  
**(11-14 Yard Range with Sideboards)**

| Item                        | Specifications (Minimum)  | Bidder’s Proposal                           |
|-----------------------------|---|---|
| <b>General Description:</b> | This Specification shall provide for new, latest current production model <u>Western/Crossmemberless Style</u> steel hydraulic dump beds complete with manufacturer’s | <u>Describe:</u><br>_____<br>_____<br>_____ |

|                           |  |  |
|---------------------------|--|--|
|                           | standard equipment and accessories, fully serviced ready to operate. To include manufacturer's certificate of warranty. (Warranty shall be the standard for the industry as offered to the public). This body shall be equipment to meet all Federal and State of Oklahoma Safety Standards and Requirements. No dealer advertisement shall be affixed to the bed. | _____<br>_____<br>_____<br>_____<br>_____            |
| <b>Body Capacity:</b>     | 11-yard sides and 14-yard Ends.  | <u>Describe:</u><br>_____<br>_____                   |
| <b>Length:</b>            | 15-Feet.   | <u>Describe:</u><br>_____<br>_____                   |
| <b>Width Inside:</b>      | 87-Inches.   | <u>Describe:</u><br>_____<br>_____                   |
| <b>Head Height:</b>       | 60-Inches.   | <u>Describe:</u><br>_____<br>_____                   |
| <b>Tail Gate Height:</b>  | 42-Inches.   | <u>Describe:</u><br>_____<br>_____                   |
| <b>Side Height:</b>       | 34-Inches, 4-bend (boxed) top rail, continuous steel with dirt shedding top.   | <u>Describe:</u><br>_____<br>_____<br>_____          |
| <b>Steel Thickness:</b>   | 7-gauge floor, 10-gauge sides and ends. With Made od A1011 Steel.  | <u>Describe:</u><br>_____<br>_____<br>_____          |
| <b>Floor:</b>             | Approx. 8-inch Radius floor to sidewall for easy cleanout.   | <u>Describe:</u><br>_____<br>_____<br>_____          |
| <b>Longitudinals:</b>     | 7-gauge A1011 channel steel.   | <u>Describe:</u><br>_____<br>_____                   |
| <b>Corner Posts Rear:</b> | Two (2) Each, Approx. 12 3/4-Inches, full depth with extra braces with 2 spreader chains, dirt shedding top.   | <u>Describe:</u><br>_____<br>_____<br>_____          |
| <b>Corner Post Front:</b> | Two (2) each full depth, Approx. 8-inches wide w/4-inch radius, dirt shedding top.   | <u>Describe:</u><br>_____<br>_____<br>_____          |
| <b>Spreader Chains:</b>   | Two (2) each.  | <u>Describe:</u><br>_____<br>_____                   |
| <b>Grab Handles:</b>      | Two (2), one on each side of gate.   | <u>Describe:</u><br>_____<br>_____                   |
| <b>Rub Rails:</b>         | Full length sloping.   | <u>Describe:</u><br>_____<br>_____                   |
| <b>Clearance Lights:</b>  | Federal Motor Vehicle Safety Standards, LED clearance lights plus LED Stop/turn lights flush mounted in the rear corner pillars, shock resistant rubber mounted. Wiring-joints soldered and shrink wrapped with loom covering.   | <u>Describe:</u><br>_____<br>_____<br>_____<br>_____ |
| <b>Light Wiring:</b>      | Joints soldered and shrink-wrapped, in a plastic convoluted loom protective covering.  | <u>Describe:</u><br>_____<br>_____<br>_____          |
| <b>Base Weight:</b>       | Show base weight of body (without hoist & accessories).  | <u>Describe:</u><br>_____<br>_____                   |

|                              |  |   |
|------------------------------|--|---|
| <b>Reflectors:</b>           | Six (6), 2 each side, 2 rear mounted on 3-inch dia. end gate, Interstate Corporation Commission approved, Federal #108, Lighting to apply. <b>NOTE:</b> These reflectors must be housed type with screw or bolt type mounting, stick-on type is not acceptable. Install Conspicuity tape on the rear on the bed. 12-foot minimum   | <u>Describe:</u><br>_____<br>_____<br>_____<br>_____          |
| <b>Tail Gate:</b>            | Double Acting with fully welded box-type 6 panel bracing and offset hardware.  | <u>Describe:</u><br>_____<br>_____                            |
| <b>NOTE:</b>                 | When Tailgate is hinged from the bottom, it must not have a gap where material can fall out.   | <u>Describe:</u><br>_____<br>_____                            |
| <b>Air Tailgate:</b>         | Air operated tailgate release with in- cab controls. The unit shall have an air activated tailgate latch, utilizing a 3-1/2-inch x 8-inch non-tie rod cylinder. The pneumatic cylinder shall be retracted when the latch is closed and shall be located at the rear of the bed to minimize the linkage necessary. The linkage shall be specifically designed to operate with the pneumatic cylinder. | <u>Describe:</u><br>_____<br>_____<br>_____<br>_____<br>_____ |
| <b>Banjo Eyes:</b>           | Four (4), two (2) each Side, 3/8-inch steel, 4-3/8-inch x 5-inch and extend beyond Rear Post.  | <u>Describe:</u><br>_____<br>_____                            |
| <b>Sideboard Braces:</b>     | 5-Inch Box Type.   | <u>Describe:</u><br>_____<br>_____                            |
| <b>Sideboard gussets:</b>    | Four (4) Each, 6-inches High, 3-inches wide.   | <u>Describe:</u><br>_____<br>_____                            |
| <b>Sideboard Extensions:</b> | Install 2-inch Oak boards tapered from front to rear of bed. Boards to be tapered so that the area from the front of the bed to allow smooth operation of a roll up type tarp system. The tailgate is completely filled.   | <u>Describe:</u><br>_____<br>_____<br>_____<br>_____          |
| <b>NOTE:</b>                 | All Channel Iron used in mounting these extensions must be assembled so the flanges are turned to the inside of the bed. This is to eliminate edges which might collect materials, on the outside of the bed.  | <u>Describe:</u><br>_____<br>_____<br>_____<br>_____          |
| <b>Brackets:</b>             | Two (2), 30-inches x 5-inches, 1/8-inch-thick Steel. (See Manufacturer's Instructions)   | <u>Describe:</u><br>_____<br>_____                            |
| <b>Mud Flaps:</b>            | Two (2) - One (1) on each side, 24inches X 30-inches Non-Sail Type. To be without any advertisement. One each mounted on each side to the rear of the duals, Non-Sail type and prevented from becoming entangled in the tires.   | <u>Describe:</u><br>_____<br>_____<br>_____<br>_____          |
| <b>Tail Gate Hardware:</b>   | Upper offset Tailgate Hinges shall be of plate steel. Lower tailgate pins shall be 1-1/4-inch diameter minimum. Lower body hardware shall be of the  | <u>Describe:</u><br>_____<br>_____<br>_____                   |

|                                    |  |   |
|------------------------------------|--|---|
|                                    | overhead type hooks and retain the 1-1/4-inch Pins in supports on each side of the hook.   | _____<br>_____<br>_____   |
| <b>NOTE:</b>                       | When Tailgate is hinged from the bottom, it must not have a gap where material can fall out.   | <u>Describe:</u><br>_____<br>_____  |
| <b>Folding Ladder</b>              | Qty of Two (2), 20-inches, 4-inch-wide metal grip strut steps attached on the front right-hand side of the body. Install a slide out, (2) rung ladder, mounted under the body just below the steps. The slide out ladder shall be on a hinged mechanism that has a positive latch system and will be locked in storage mode or when retracted out will hinge down and be locked in a stable configuration for safe utilization and accessible from the ground. The steps and the 2 rung ladder will allow access from the ground to the top of the body. | <u>Describe:</u><br>_____<br>_____<br>_____<br>_____<br>_____<br>_____<br>_____<br>_____<br>_____ |
| <b>Tarp Tie Down Rails:</b>        | Full length both sides to be 5/8-inch reinforcing bar, 3-inch high from extreme top outer edge of Rub Rail.  | <u>Describe:</u><br>_____<br>_____  |
| <b>Mounting Height:</b>            | Not to exceed 12-3/8-inches from top of truck frame to floor of body.  | <u>Describe:</u><br>_____<br>_____  |
| <b>Cab Shield:</b>                 | Full Cab Shield - Full Width of Bed  | <u>Describe:</u><br>_____<br>_____  |
| <b>Safety Strut:</b>               | All dump beds must be equipped with Safety Strut to hold bed in the 'UP' position while repairs are being made. (ONE EACH SIDE).   | <u>Describe:</u><br>_____<br>_____<br>_____   |
| <b>Spreader Tie Down "D" Rings</b> | Install four (4) 1/2-inch dia. "D" Rings on lower rub rail; 2 on each side with one mounted 24-inches from the front and one mounted 24-inches from the rear of body. Must have the capability of ratcheting the spreader chains from a standing position on the ground.   | <u>Describe:</u><br>_____<br>_____<br>_____<br>_____  |
| <b>Electric Tarp Kit</b>           | Donovan 7000ELD electric tarp kit or approved equal with control box. A wind deflector: 16-gauge galvanized steel. A 3/16-inch removeable plate shall be installed over the top of the tarp roll up mechanism to protect it from damage.   | <u>Describe:</u><br>_____<br>_____<br>_____<br>_____  |
| <b>Trailer Tow Pkg:</b>            | Complete trailer package for pulling air brake trailers. To include air lines plumbed to rear of frame from the factory source (To be supplied by the truck manufacturer). Furnish and install glad hands and 7-way electrical connector at rear of frame ready to use with a 6 to 7-way adaptor. Air couplers and electrical connections are to be mounted as high as possible in the hinge area and plumbed in such a way as to not interfere with dumping of the bed or sand spreader operation and to avoid contact when pulling trailers.           | <u>Describe:</u><br>_____<br>_____<br>_____<br>_____<br>_____<br>_____<br>_____<br>_____          |
| <b>Pintle Hitch:</b>               | Reinforced trailer hitch mounted on a 5/8-inch plate, gusseted, with a 90,000 lb. pintle hitch, Holland PH210  | <u>Describe:</u><br>_____<br>_____  |

|   |   |   |
|---|---|---|
|   | or equal. Trailer safety rings are Crosby weldless links per Item 21, to match capacity of hitch. Air lines to have quick disconnect fittings behind air operated pintle hitch so hitch may be removed during certain operations of the dump truck such as spreader operations.   | _____<br>_____<br>_____<br>_____  |
| <b>Strobes, Front &amp; Rear:</b>                 | Furnish and install two strobes on each side in rear corner pillars per Item 5 of this IFB and two strobes in front grill area.   | <u>Describe:</u><br>_____<br>_____<br>_____                                     |
| <b>Warranty:</b>                                  | Body manufacturer shall provide a written 5-year warranty covering repair or replacement of the body, hoist and air cylinder for defective material and/or workmanship. Warranty shall include all freight and labor for repairs or replacement. Warranty shall also include adherence of primer to all metal surfaces not including inside or understructure of dump bodies. The manufacturer's warranty must be submitted with Bid. | <u>Describe:</u><br>_____<br>_____<br>_____<br>_____<br>_____<br>_____<br>_____ |
| <b>Note:</b>                                      | Warranty labor and parts replacement must be handled by an in-state authorized dealer, who can provide immediate replacement without charge or delay. "See Specification Header at beginning of Bid Specifications".  | <u>Describe:</u><br>_____<br>_____<br>_____<br>_____                            |
| <b>Hydraulic Hoist, Pump &amp; Control Valve:</b> | Class 120.  | <u>Describe:</u><br>_____<br>_____  |
| <b>Cylinder:</b>                                  | Show inside diameter & piston diameter and stroke, 1st active sleeve, _____" 2nd, _____", 3 <sup>rd</sup> , _____" and base tube ___" stroke, single acting, self-adjusting V-type packing interior guide bushing – chrome plated cylinder.   | <u>Describe:</u><br>_____<br>_____<br>_____<br>_____                            |
| <b>Hoist Capacity:</b>                            | Minimum lift 37-tons net payload.   | <u>Describe:</u><br>_____<br>_____  |
| <b>Dump Angle:</b>                                | 50-Degrees Maximum.   | <u>Describe:</u><br>_____<br>_____  |
| <b>Auto Bleed System:</b>                         | An internal spring assisted device to automatically remove air from the cylinder and hydraulic lines whenever the cylinder is extended and retracted. The device shall not bleed air directly to atmosphere and shall use hydraulic fluid to push air out of the cylinder and back to tank.   | <u>Describe:</u><br>_____<br>_____<br>_____<br>_____<br>_____                   |
| <b>Oil Reservoir:</b>                             | Capacity: 28-gallons, shut off valve on the suction port Reservoir located on outside of frame.   | <u>Describe:</u><br>_____<br>_____<br>_____                                     |
| <b>Low Hydraulic Fluid Warning Light</b>          | Must install in the cab a Low Hydraulic Fluid Warning Light within easy view of driver.   | <u>Describe:</u><br>_____<br>_____<br>_____                                     |

|                                       |   |   |
|---------------------------------------|---|---|
| <b>Rear Pivot Hinges:</b>             | Double shear type - 2 hinge pins 1-3/4-inch x 8-inch.   | <u>Describe:</u><br>_____   |
| <b>Hydraulic Pump</b>                 | 19-GPM @ 2,500 PSI, 1,000 RPM, Pump to be mounted directly on PTO.  | <u>Describe:</u><br>_____<br>_____  |
| <b>Relief Valve:</b>                  | Built into valve.   | <u>Describe:</u><br>_____   |
| <b>Shaft Bearings:</b>                | Roller Bearings Standard.   | <u>Describe:</u><br>_____   |
| <b>Control Valve:</b>                 | 4 Position (raised, hold, feather, and lower).  | <u>Describe:</u><br>_____   |
| <b>Controls:</b>                      | Locking lever pedestal control with <u>BODY UP</u> audio and visual alarm. A locking device to lock controls in neutral position shall be provided. Connect lever and valve with a 1/4-inch sealed cable. Valves to be Gresen model V-20.   | <u>Describe:</u><br>_____<br>_____<br>_____<br>_____  |
| <b>Power Take-Off:</b>                | Direct driven from transmission to hydraulic pump. PTO to have enabler capability (i.e. "Hot Shift" Type) with electronic "overspeed protection" to prevent PTO from turning at more RPM than system is designed to handle. Must be geared to allow continuous operation at 0-30 MPH. Electronic dash mounted controls with engagement light, no levers or cables, must be able to shift PTO while truck is in motion 15 to 20 MPH.   | <u>Describe:</u><br>_____<br>_____<br>_____<br>_____<br>_____<br>_____  |
| <b>Over Speed Protection For PTO:</b> | Fully Adjustable from 300 to 3000 RPM   | <u>Describe:</u><br>_____   |
| <b>OPTIONS:</b>                       | <ol style="list-style-type: none"> <li>1. <u>Central Hydraulic System with Quick Disconnect:</u> Muncie MP2 central hydraulic system or acceptable equal capable of operating the dump body hoist, snow plow up/down/left/right and sand spreader spinner and conveyor. (see specification below).</li> <li>2. <u>Spread Apron:</u> 12-inch spread apron, 10-gauge Steel.</li> <li>3. <u>Ball Hitch:</u> Reinforced trailer hitch mounted on a 5/8-inch plate, gusseted, with a Buyers or Kernis K300 2 5/16-inch ball hitch rated at 16,000 LB. Trailer safety rings are Crosby weldless links per Item 21 to match capacity of hitch. To include glad hands and 7-Way light connection.</li> <li>4. <u>Toolbox:</u> Frame mounted toolbox, Rawson-Koenig H361818 or equal.</li> <li>5. <u>Sideboards:</u> <ol style="list-style-type: none"> <li>A. In place of the 2-inch Oak Boards, install Rumbar type material 2-inch boards tapered from front to rear of bed so that the area from the front of the bed to the rear to allow smooth operation of a roll up type tarp system.</li> <li>B. In place of the 2-inch Oak Boards, install 10 gauge "C" channel reinforced every 3-feet bolted</li> </ol> </li> </ol> | <u>Describe:</u><br>1 _____<br>_____<br>_____<br>_____<br>2 _____<br>_____<br>_____<br>_____<br>3 _____<br>_____<br>_____<br>_____<br>4 _____<br>_____<br>_____<br>_____<br>5 _____<br>A _____<br>_____<br>_____<br>_____<br>B _____<br>_____ |

|  |   |   |
|--|---|---|
|  | in place tapered from front to rear of bed to allow smooth operation of a roll up type tarp system.   |   |
|  | 6. <b>Controls:</b> Air operated controls for raising and lowering dump bed. Controls shall be of the type to enable operator to feather the bed down.<br>** This system not required if installing a Central Hydraulic System with Quick Disconnect. | 6 |
|  | 7. <b>Flooring:</b> 1/4-inch-thick steel floor in lieu of 7-gauge.  | 7 |
|  | 8. <b>Steps:</b> Qty of (2), 20-inch steps, 4-inch-wide metal grip strut located on the right front side corner of the body. No folding ladder.   | 8 |

**TAILLIGHTS:** Taillights of vehicle are to be mounted on the outside of the truck frame. Taillights shall be installed within a protected bracket to prevent them from being knocked off accidentally. Lens should be protected with expanded metal.

**MOUNTING INSTRUCTIONS:** The front mounting brackets on each side of the frame shall be drilled and bolted, not welded to the truck frame. The hydraulic pump shall be direct mounted to the Power take off. The rear end of the truck frame to be cut the least amount to allow the bed to reach maximum dumping position. The truck frame shall be cut at a right angle or square cut rather than tapered. (The trimmed material must be left in the truck bed.)

The following requirements will be necessary if there is no safeguard to prevent the bed from being raised too high or beyond the return point of the hydraulic hoist cylinders:

Safety bed stop blocks of enough thickness to provide this protection must be mounted behind the bed hinges between the bed and truck frame.

**NOTE:** Seller must NOT remove identification plates or numbers on the truck. This especially applies to the truck transmission when power take-off installed. If, during installation, it becomes necessary to remove these plates or cover these numbers, they must be replaced in a visible location.

**ELECTRICAL WIRING:** Wiring to be in loom and properly secured to frame to prevent sagging. Upon completion of installation all connections, splices and wiring to be protected by all-weather insulation. This insulation material to be of sufficient quality to insure a life period of five (5) years.

**\*POWER TAKE OFF:** Must be the latest current model installed and/or adapted to fit the transmission. Mounting bolts or screws must provide adequate self-locking and sealing to insure against oil leaks and must keep housing firmly attached to transmission.

**FRONT CLEARANCE LIGHTS:** To be installed under the front lower corner.

**PAINT:** All exposed metal shall be primed and painted. The bed shall be sprayed or dipped with a protective metal primer, then be painted Factory White to match vehicle.

**Hydraulic Central Control System for Snow and Ice Equipment:** Install a Muncie MP2 central hydraulic system or acceptable equal capable of operating the dump body hoist, snow plow up/down/left/right and sand spreader spinner and conveyor.

The sand spreader system shall contain a 3/4" pressure line for the spinner and a 3/4" pressure line for the conveyor and a single 1" return line. These lines will be hard piped from the hoist area to the rear of the truck. The spinner quick connect shall be an Eaton #5602-12-12S or acceptable equal. The conveyor quick connect shall be an Eaton #5601-12-12S or acceptable equal. The return quick connect shall be an Eaton #5602-16-16S or acceptable equal. All quick connects must be compatible with existing quick connects of same size being utilized in the current fleet of trucks so all sand spreaders units are compatible with any truck utilized. All quick connects are to be mounted on the rear curbside of the dump body approximately 10" from the rear (contact a City of Tulsa

representative for an exact location. All quick connects to have a protective cover. These quick connects shall be mounted so they will not interfere with dumping of the bed or with use of the Pintle Hitch.

The Hydraulic Valving shall be as follows. The circuit design shall include Load-Sensing communication from all valves. The valves shall be solenoid operated carriage style with a common manifold and rated IP69. There shall be a flow priority to insure operation of the cylinder functions whenever the spreader is operating, and pump flow is critically low. All cylinders shall have proportional flow control on the power sequence to afford cylinder speed control. Pressure relief valves shall have an independent stem adjustable pressure protection included for the manifold inlet, the spreader, the downside of all double acting cylinders and plow angle cylinders. The plow lift valves shall be capable of four-way control and have a flow capacity of 15 GPM. The raise side of the circuit shall be rated for zero leakage. The plow angle valves shall be capable of four-way control and have a flow capacity of 15 GPM. Load Locking check valves) or Motor Spool design) shall be included as required to support the angling mechanism used. The dump hoist valves shall have a four-way control and have a flow capacity of 30 GPM. Counterbalance control valves shall be included. The spreader proportional control valves for the auger, conveyor, and spinner motors shall have flow capacities of 15/7 GPM respectively. These valves shall be pressure compensated and parallel in their circuit architecture.

The System Controls commands to the system valves shall be digitally encoded and sent over the vehicles electrical system using only a 12-volt DC and ground connection at each end of the system.

The valve driver modules shall be housed in Deutsch boxes employ Deutsch connectors at solenoids or acceptable equal giving IP69 environmental rating. The valve driver modules shall be equipped with current sensing control to offset thermal changes in solenoid performance and to detect open or short circuit conditions and protect against the latter by automatic interruption of current to the shorted output.

Cylinder momentary push button switches will provide on-off style control of the plow and dump body operations. Program settings will provide effective and independent flow trims for plow up-down, plow angle and dump up-down.

A two-axis cylinder proportioning joystick with dead man switch and pushbutton selection of equipment shall be provided. The joystick shall employ dual redundant hall-effect mechanisms, eliminating the wear of potentiometer or other contact mechanisms. In the event of failure of one hall-effect output a program adjustment to system controller will allow selection of the alternate channel. The same controller will also provide electronic adjustment of one degree from center for operation, minimum valve drive at minimum joystick deflection, and maximum valve drive at maximum joystick deflection. Adjustments for degrees from center operation and the minimum valve drive at minimum joystick deflection will be independent for the plow and dump. The joystick shall plug to the control panel as its only connection point. Connection of the joystick will render the pushbutton cylinder controls inoperable. Conversely, disconnection of the joystick will reactivate the pushbutton controls. Selection of the equipment function by pushbuttons on the head of the joystick will illuminate an equipment identity label on the control panel. No operation of the joystick can take place without holding the dead man switch.

The spreader controls modes of operation shall provide a selectable automatic and manual control. There shall be a Blast operation with programmable selection of level and time. A Pause operation shall be available to momentarily disable the spreader operation.

A feedback sensor shall not be required to achieve accurate and consistent operation of the spreader functions. High brightness LED numerical displays will be used to indicate one of 11 reference controls positions for the spinner and auger (manual mode). In Auto operation the auger display will indicate "pounds per mile" if the system has been calibrated for such.

The system shall display fault occurrences of shorted or open outputs at the valves with indication of which circuit is responsible.

All controls will be mounted in the truck cab. The joystick shall be mounted on a pedestal style mechanism beside the driver at a level and location that is comfortable to operate, allowing the driver to operate at a glance without taking his eyes completely off the road. The Control display panel shall be mounted in the dash area and at a level easily viewed by the driver.



An integral valve/tank enclosure assembly shall be mounted to the frame rail of the vehicle. The reservoir and dry compartment shall be made of 7-gauge mild powder coated steel and the lid assembly shall be made of 10-gauge mild powder coated steel painted black to match the frame rails.

The bottom portion of the valve/tank integral design shall house a minimum of 35-gallons of hydraulic oil with temperature/sight gauge mounted on the front face. The reservoir shall be properly baffled with a drain plug in the bottom and provision in the top for an in-tank, glass type return line filter. There shall also be a fill tube vented cap assembly that will also serve as a clean out port. The filter will be a minimum of 10 micron and the element shall be easily removed for replacement.

The top portion of the valve/tank assembly will be dry with a rubber seal that will provide protection when the lid assembly is in place. This area will house the tube/vented cap, return line in-tank filter, the solenoid control valve manifold, and the PLC electronic command modules.

The solenoid control manifold valve will mount in the enclosure against the back wall allowing for all cylinder and spreader hose connections to be mounted directly to this assembly. The back of the manifold assembly will be bolted to the back wall in a way to prevent outside contamination and to allow for the O ring fittings for hose connections to the direct entry eliminating the need for internal cylinder and spreader hose plumbing. The valve/tank assembly shall be narrow or stepped from the frame of the vehicle to allow for ample room for installation and servicing of the hoses.

The PLC modules will be contained to the back wall of the enclosure and will allow for easy servicing. The wiring from the manifold cartridge solenoids will plug into these two modules and the power, ground, and ground speed control conductors will exit the enclosure with a strain relief sealed connector.

The lid will set on a perimeter gasket and will be retained with four over-center chrome latches for easy access and removal. The entire valve/tank enclosure will be mounted to the frame in a cradle fabricated by the installer to properly support the assembly.

**ITEM 32: 13 Cubic Yard Stainless Steel Dump Body – 126-inch CA  
(11-14 Yard Range with Sideboards)**

| Item                        | Specifications (Minimum)  | Bidder's Proposal   |
|-----------------------------|---|---|
| <b>General Description:</b> | This Specification shall provide for new, latest current production model <u>Western/Crossmemberless Style</u> , Stainless Steel, hydraulic dump beds complete with manufacturer's standard equipment and accessories, fully serviced ready to operate. To include manufacturer's certificate of warranty. (Warranty shall be the standard for the industry as offered to the public). This body shall be equipment to meet all Federal and State of Oklahoma Safety Standards and Requirements. No dealer advertisement shall be affixed to the bed. | Describe:<br>_____<br>_____<br>_____<br>_____<br>_____<br>_____<br>_____<br>_____ |
| <b>Body Capacity:</b>       | 11-yard sides and 14-yard Ends.   | Describe:<br>_____  |
| <b>Length:</b>              | 15-Feet.  | Describe:<br>_____  |
| <b>Width Inside:</b>        | 87-Inches.  | Describe:<br>_____  |
| <b>Head Height:</b>         | 60-Inches.  | Describe:<br>_____  |
| <b>Tail Gate Height:</b>    | 42-Inches.  | Describe:<br>_____  |

|                           |   |   |
|---------------------------|---|---|
| <b>Side Height:</b>       | 34-Inches, 4-bend (boxed) top rail, continuous Stainless steel with dirt shedding top.  | <u>Describe:</u><br>_____<br>_____                            |
| <b>Steel Thickness:</b>   | 7-gauge floor, 10-gauge sides and ends. With Made od A1011 Stainless Steel.   | <u>Describe:</u><br>_____<br>_____                            |
| <b>Floor:</b>             | Approx. 8-inch Radius floor to sidewall for easy cleanout.  | <u>Describe:</u><br>_____<br>_____                            |
| <b>Longitudinals:</b>     | 7-gauge A1011 channel Stainless Steel.  | <u>Describe:</u><br>_____<br>_____                            |
| <b>Corner Posts Rear:</b> | Two (2) Each, Approx. 12 3/4-Inches, full depth with extra braces with 2 spreader chains, dirt shedding top.  | <u>Describe:</u><br>_____<br>_____                            |
| <b>Corner Post Front:</b> | Two (2) each full depth, Approx. 8-inches wide w/4-inch radius, dirt shedding top.  | <u>Describe:</u><br>_____<br>_____                            |
| <b>Spreader Chains:</b>   | Two (2) each.   | <u>Describe:</u><br>_____<br>_____                            |
| <b>Grab Handles:</b>      | Two (2), one on each side of gate.  | <u>Describe:</u><br>_____<br>_____                            |
| <b>Rub Rails:</b>         | Full length sloping.  | <u>Describe:</u><br>_____<br>_____                            |
| <b>Clearance Lights:</b>  | Federal Motor Vehicle Safety Standards, LED clearance lights plus LED Stop/turn lights flush mounted in the rear corner pillars, shock resistant rubber mounted. Wiring-joints soldered and shrink wrapped with loom covering.  | <u>Describe:</u><br>_____<br>_____<br>_____<br>_____          |
| <b>Light Wiring:</b>      | Joints soldered and shrink-wrapped, in a plastic convoluted loom protective covering.   | <u>Describe:</u><br>_____<br>_____                            |
| <b>Base Weight:</b>       | Show base weight of body (without hoist & accessories).   | <u>Describe:</u><br>_____<br>_____                            |
| <b>Reflectors:</b>        | Six (6), 2 each side, 2 rear mounted on 3-inch dia. end gate, Interstate Corporation Commission approved, Federal #108, Lighting to apply. <b>NOTE:</b> These reflectors must be housed type with screw or bolt type mounting, stick-on type is not acceptable. Install Conspicuity tape on the rear on the bed. 12-feet minimum. | <u>Describe:</u><br>_____<br>_____<br>_____<br>_____<br>_____ |
| <b>Tail Gate:</b>         | Double Acting with fully welded box-type 6 panel bracing and offset hardware.   | <u>Describe:</u><br>_____<br>_____                            |
| <b>NOTE:</b>              | When Tailgate is hinged from the bottom, it must not have a gap where material can fall out.  | <u>Describe:</u><br>_____<br>_____                            |
| <b>Air Tailgate:</b>      | Air operated tailgate release with in- cab controls. The unit shall have an air activated tailgate latch, utilizing a 3-1/2-inch x 8-inch non-tie rod cylinder. The pneumatic cylinder shall be retracted when the latch is closed and  | <u>Describe:</u><br>_____<br>_____<br>_____<br>_____          |

|                              |  |  |
|------------------------------|--|--|
|                              | shall be located at the rear of the bed to minimize the linkage necessary. The linkage shall be specifically designed to operate with the pneumatic cylinder.  | _____<br>_____<br>_____  |
| <b>Banjo Eyes:</b>           | 4, 2 Each Side 3/8-inch steel, 4-3/8-inch x 5-inch and extend beyond Rear Post.  | <u>Describe:</u><br>_____<br>_____   |
| <b>Sideboard Braces:</b>     | 5-Inch Box Type.   | <u>Describe:</u><br>_____<br>_____   |
| <b>Sideboard gussets:</b>    | Four (4) Each, 6-inches High, 3-inches wide.   | <u>Describe:</u><br>_____<br>_____   |
| <b>Sideboard Extensions:</b> | Install 2-inch Oak boards tapered from front to rear of bed. Boards to be tapered so that the area from the front of the bed to allow smooth operation of a roll up type tarp system. The tailgate is completely filled.   | <u>Describe:</u><br>_____<br>_____<br>_____<br>_____<br>_____                            |
| <b>Note:</b>                 | All Channel Iron used in mounting these extensions must be assembled so the flanges are turned to the inside of the bed. This is to eliminate edges which might collect materials, on the outside of the bed.  | <u>Describe:</u><br>_____<br>_____<br>_____<br>_____                                     |
| <b>Brackets:</b>             | Two (2), 30-inches x 5-inches, 1/8-inch thick Stainless Steel. (See Manufacturer's Instructions)   | <u>Describe:</u><br>_____<br>_____   |
| <b>Mud Flaps:</b>            | Two (2) - One (1) on each side, 24inches X 30-inches Non-Sail Type. To be without any advertisement. One each mounted on each side to the rear of the duals, Non-Sail type and prevented from becoming entangled in the tires.   | <u>Describe:</u><br>_____<br>_____<br>_____<br>_____                                     |
| <b>Tail Gate Hardware:</b>   | Upper offset Tailgate Hinges shall be of plate Stainless Steel. Lower tailgate pins shall be 1-1/4-inch diameter minimum. Lower body hardware shall be of the overhead type hooks and retain the 1-1/4-inch Pins in supports on each side of the hook.   | <u>Describe:</u><br>_____<br>_____<br>_____<br>_____                                     |
| <b>NOTE:</b>                 | When Tailgate is hinged from the bottom, it must not have a gap where material can fall out.   | <u>Describe:</u><br>_____<br>_____   |
| <b>Folding Ladder</b>        | Qty of Two (2), 20-inches, 4-inch-wide metal grip strut steps attached on the front right-hand side of the body. Install a slide out, (2) rung ladder, mounted under the body just below the steps. The slide out ladder shall be on a hinged mechanism that has a positive latch system and will be locked in storage mode or when retracted out will hinge down and be locked in a stable configuration for safe utilization and accessible from the ground. The steps and the 2 rung ladder will allow access from the ground to the top of the body. | <u>Describe:</u><br>_____<br>_____<br>_____<br>_____<br>_____<br>_____<br>_____<br>_____ |

|                                    |  |   |
|------------------------------------|--|---|
| <b>Tarp Tie Down Rails:</b>        | Full length both sides to be 5/8-inch reinforcing bar, 3-inch high from extreme top outer edge of Rub Rail.  | <u>Describe:</u><br>_____<br>_____  |
| <b>Mounting Height:</b>            | Not to exceed 12-3/8-inches from top of truck frame to floor of body.  | <u>Describe:</u><br>_____<br>_____  |
| <b>Cab Shield:</b>                 | Full Cab Shield - Full Width of Bed.   | <u>Describe:</u><br>_____<br>_____  |
| <b>Safety Strut:</b>               | All dump beds must be equipped with Safety Strut to hold bed in the 'UP' position while repairs are being made. (ONE EACH SIDE).   | <u>Describe:</u><br>_____<br>_____<br>_____                                     |
| <b>Spreader Tie Down "D" Rings</b> | Install four (4) 1/2-inch dia. "D" Rings on lower rub rail; 2 on each side with one mounted 24-inches from the front and one mounted 24-inches from the rear of body. Must have the capability of ratcheting the spreader chains from a standing position on the ground.   | <u>Describe:</u><br>_____<br>_____<br>_____<br>_____                            |
| <b>Electric Tarp Kit</b>           | Donovan 7000ELD electric tarp kit or approved equal with control box. A wind deflector: 16-gauge galvanized steel. A 3/16-inch removeable plate shall be installed over the top of the tarp roll up mechanism to protect it from damage.   | <u>Describe:</u><br>_____<br>_____<br>_____<br>_____                            |
| <b>Trailer Tow Pkg:</b>            | Complete trailer package for pulling air brake trailers. To include air lines plumbed to rear of frame from the factory source (To be supplied by the truck manufacturer). Furnish and install glad hands and 7-way electrical connector at rear of frame ready to use with a 6 to 7-way adaptor. Air couplers and electrical connections are to be mounted as high as possible in the hinge area and plumbed in such a way as to not interfere with dumping of the bed or sand spreader operation and to avoid contact when pulling trailers. | <u>Describe:</u><br>_____<br>_____<br>_____<br>_____<br>_____<br>_____<br>_____ |
| <b>Pintle Hitch:</b>               | Reinforced trailer hitch mounted on a 5/8-inch plate, gusseted, with a 90,000 lb. pintle hitch, Holland PH210 or equal. Trailer safety rings are Crosby weldless links per Item 21, to match capacity of hitch. Air lines to have quick disconnect fittings behind air operated pintle hitch so hitch may be removed during certain operations of the dump truck such as spreader operations.  | <u>Describe:</u><br>_____<br>_____<br>_____<br>_____<br>_____                   |
| <b>Strobes, Front &amp; Rear:</b>  | Furnish and install two strobes on each side in rear corner pillars per Item 5 of this IFB and two strobes in front grill area.  | <u>Describe:</u><br>_____<br>_____<br>_____                                     |
| <b>Warranty:</b>                   | Body manufacturer shall provide a written 5-year warranty covering repair or replacement of the body, hoist and air cylinder for defective material and/or workmanship. Warranty shall include all freight and labor for repairs or replacement. Warranty shall also include adherence of primer to all metal surfaces not including   | <u>Describe:</u><br>_____<br>_____<br>_____<br>_____<br>_____                   |

|   |   |  |
|---|---|--|
|   | inside or understructure of dump bodies. The manufacturer's warranty must be submitted with Bid.  | _____<br>_____<br>_____                              |
| <b>Note:</b>                                      | Warranty labor and parts replacement must be handled by an in-state authorized dealer, who can provide immediate replacement without charge or delay. "See Specification Header at beginning of Bid Specifications".  | <u>Describe:</u><br>_____<br>_____<br>_____          |
| <b>Hydraulic Hoist, Pump &amp; Control Valve:</b> | Class 120.  | <u>Describe:</u><br>_____<br>_____                   |
| <b>Cylinder:</b>                                  | Show inside diameter & piston diameter and stroke, 1st active sleeve, _____" 2nd, _____", 3 <sup>rd</sup> , _____" and base tube ___" stroke, single acting, self-adjusting V-type packing interior guide bushing – chrome plated cylinder.   | <u>Describe:</u><br>_____<br>_____<br>_____          |
| <b>Hoist Capacity:</b>                            | Minimum lift 37-tons net payload.   | <u>Describe:</u><br>_____                            |
| <b>Dump Angle:</b>                                | 50-Degrees Maximum.   | <u>Describe:</u><br>_____                            |
| <b>Auto Bleed System:</b>                         | An internal spring assisted device to automatically remove air from the cylinder and hydraulic lines whenever the cylinder is extended and retracted. The device shall not bleed air directly to atmosphere and shall use hydraulic fluid to push air out of the cylinder and back to tank. | <u>Describe:</u><br>_____<br>_____<br>_____<br>_____ |
| <b>Oil Reservoir:</b>                             | Capacity: 28-gallons, shut off valve on the suction port Reservoir located on outside of frame.   | <u>Describe:</u><br>_____<br>_____                   |
| <b>Low Hydraulic Fluid Warning Light</b>          | Must install in the cab a Low Hydraulic Fluid Warning Light within easy view of driver.   | <u>Describe:</u><br>_____<br>_____                   |
| <b>Rear Pivot Hinges:</b>                         | Double shear type - 2 hinge pins 1-3/4-inch x 8-inch.   | <u>Describe:</u><br>_____<br>_____                   |
| <b>Hydraulic Pump</b>                             | 19-GPM @ 2,500 PSI, 1,000 RPM, Pump to be mounted directly on PTO.  | <u>Describe:</u><br>_____<br>_____                   |
| <b>Relief Valve:</b>                              | Built into valve.   | <u>Describe:</u><br>_____                            |
| <b>Shaft Bearings:</b>                            | Roller Bearings Standard.   | <u>Describe:</u><br>_____                            |
| <b>Control Valve:</b>                             | 4 Position (raised, hold, feather, and lower).  | <u>Describe:</u><br>_____<br>_____                   |
| <b>Controls:</b>                                  | Locking lever pedestal control with BODY UP audio and visual alarm. A locking device to lock controls in neutral position shall be provided. Connect lever and valve with a 1/4-inch sealed cable. Valves to be Gresen model V-20.  | <u>Describe:</u><br>_____<br>_____<br>_____<br>_____ |

|  |   |   |
|--|---|---|
| <p><b>Power Take-Off:</b></p>                | <p>Direct driven from transmission to hydraulic pump. PTO to have enabler capability (i.e. "Hot Shift" Type) with electronic "overspeed protection" to prevent PTO from turning at more RPM than system is designed to handle. Must be geared to allow continuous operation at 0-30 MPH. Electronic dash mounted controls with engagement light, no levers or cables, must be able to shift PTO while truck is in motion 15 to 20 MPH.</p>  | <p><u>Describe:</u></p> <p>_____</p> <p>_____</p> <p>_____</p> <p>_____</p> <p>_____</p>  |
| <p><b>Over Speed Protection For PTO:</b></p> | <p>Fully Adjustable from 300 to 3000 RPM</p>  | <p><u>Describe:</u></p> <p>_____</p> <p>_____</p>   |
| <p><b>Options</b></p>                        | <ol style="list-style-type: none"> <li>1. <u>Central Hydraulic System with Quick Disconnect:</u> Muncie MP2 central hydraulic system or acceptable equal capable of operating the dump body hoist, snow plow up/down/left/right and sand spreader spinner and conveyor. (see specification below).</li> <li>2. <u>Spread Apron:</u> 12-inch spread apron, 10-gauge Steel.</li> <li>3. <u>Ball Hitch:</u> Reinforced trailer hitch mounted on a 5/8-inch plate, gusseted, with a Buyers or Kernis K300 2 5/16-inch ball hitch rated at 16,000 LB. Trailer safety rings are Crosby weldless links per Item 21 to match capacity of hitch. To include glad hands and 7-Way light connection.</li> <li>4. <u>Toolbox:</u> Frame mounted toolbox, Rawson-Koenig H361818 or equal.</li> <li>5. <u>Sideboards:</u> <ol style="list-style-type: none"> <li>A. In place of the 2-inch Oak Boards, install Rumbar type material 2-inch boards tapered from front to rear of bed so that the area from the front of the bed to the rear to allow smooth operation of a roll up type tarp system.</li> <li>B. In place of the 2-inch Oak Boards, install 10 gauge "C" channel reinforced every 3-feet bolted in place tapered from front to rear of bed to allow smooth operation of a roll up type tarp system.</li> </ol> </li> <li>6. <u>Controls:</u> Air operated controls for raising and lowering dump bed. Controls shall be of the type to enable operator to feather the bed down.<br/>                 ** This system not required if installing a Central Hydraulic System with Quick Disconnect.</li> <li>7. <u>Flooring:</u> 1/4-inch-thick steel floor in lieu of 7-gauge.</li> <li>8. <u>Steps:</u> Qty of (2), 20-inch steps, 4-inch-wide metal grip strut located on the right front side corner of the body. No folding ladder.</li> </ol> | <p><u>Describe:</u></p> <p>1 _____</p> <p>_____</p> <p>_____</p> <p>_____</p> <p>_____</p> <p>2 _____</p> <p>_____</p> <p>_____</p> <p>_____</p> <p>_____</p> <p>3 _____</p> <p>_____</p> <p>_____</p> <p>_____</p> <p>_____</p> <p>4 _____</p> <p>_____</p> <p>_____</p> <p>_____</p> <p>5 _____</p> <p>A _____</p> <p>_____</p> <p>_____</p> <p>_____</p> <p>B _____</p> <p>_____</p> <p>_____</p> <p>_____</p> <p>6 _____</p> <p>_____</p> <p>_____</p> <p>_____</p> <p>7 _____</p> <p>_____</p> <p>8 _____</p> <p>_____</p> |

**TAILLIGHTS:** Taillights of vehicle are to be mounted on the outside of the truck frame. Taillights shall be installed within a protected bracket to prevent them from being knocked off accidentally. Lens should be protected with expanded metal.

**MOUNTING INSTRUCTIONS:** The front mounting brackets on each side of the frame shall be drilled and bolted, not welded to the truck frame. The hydraulic pump shall be direct mounted to the Power take off.

The rear end of the truck frame to be cut the least amount to allow the bed to reach maximum dumping position. The truck frame shall be cut at a right angle or square cut rather than tapered. (The trimmed material must be left in the truck bed.)

The following requirements will be necessary if there is no safeguard to prevent the bed from being raised too high or beyond the return point of the hydraulic hoist cylinders:

Safety bed stop blocks of enough thickness to provide this protection must be mounted behind the bed hinges between the bed and truck frame.

**NOTE:** Seller must NOT remove identification plates or numbers on the truck. This especially applies to the truck transmission when power take-off installed. If, during installation, it becomes necessary to remove these plates or cover these numbers, they must be replaced in a visible location.

**ELECTRICAL WIRING:** Wiring to be in loom and properly secured to frame to prevent sagging. Upon completion of installation all connections, splices and wiring to be protected by all-weather insulation. This insulation material to be of sufficient quality to insure a life period of five (5) years.

**\*POWER TAKE OFF:** Must be the latest current model installed and/or adapted to fit the transmission. Mounting bolts or screws must provide adequate self-locking and sealing to insure against oil leaks and must keep housing firmly attached to transmission.

**FRONT CLEARANCE LIGHTS:** To be installed under the front lower corner.

**PAINT:** All exposed metal shall be primed and painted. The bed shall be sprayed or dipped with a protective metal primer, then be painted Factory White to match vehicle.

**Hydraulic Central Control System for Snow and Ice Equipment:** Install a Muncie MP2 central hydraulic system or acceptable equal capable of operating the dump body hoist, snow plow up/down/left/right and sand spreader spinner and conveyor.

The sand spreader system shall contain a 3/4" pressure line for the spinner and a 3/4" pressure line for the conveyor and a single 1" return line. These lines will be hard piped from the hoist area to the rear of the truck. The spinner quick connect shall be an Eaton #5602-12-12S or acceptable equal. The conveyor quick connect shall be an Eaton #5601-12-12S or acceptable equal. The return quick connect shall be an Eaton #5602-16-16S or acceptable equal. All quick connects must be compatible with existing quick connects of same size being utilized in the current fleet of trucks so all sand spreaders units are compatible with any truck utilized. All quick connects are to be mounted on the rear curbside of the dump body approximately 10" from the rear (contact a City of Tulsa representative for an exact location. All quick connects to have a protective cover. These quick connects shall be mounted so they will not interfere with dumping of the bed or with use of the Pintle Hitch.

The Hydraulic Valving shall be as follows. The circuit design shall include Load-Sensing communication from all valves. The valves shall be solenoid operated carriage style with a common manifold and rated IP69. There shall be a flow priority to insure operation of the cylinder functions whenever the spreader is operating, and pump flow is critically low. All cylinders shall have proportional flow control on the power sequence to afford cylinder speed control. Pressure relief valves shall have an independent stem adjustable pressure protection included for the manifold inlet, the spreader, the downside of all double acting cylinders and plow angle cylinders. The plow lift valves shall be capable of four-way control and have a flow capacity of 15 GPM. The raise side of the circuit shall be rated for zero leakage. The plow angle valves shall be capable of four-way control and have a flow capacity of 15 GPM. Load Locking check valves) or Motor Spool design) shall be included as required to support the angling mechanism used. The dump hoist valves shall have a four-way control and have a flow capacity of 30 GPM. Counterbalance control valves shall be included. The spreader proportional control valves for the auger, conveyor, and spinner motors shall have flow capacities of 15/7 GPM respectively. These valves shall be pressure compensated and parallel in their circuit architecture.

The System Controls commands to the system valves shall be digitally encoded and sent over the vehicles electrical system using only a 12-volt DC and ground connection at each end of the system.

The valve driver modules shall be housed in Deutsch boxes employ Deutsch connectors at solenoids or acceptable equal giving IP69 environmental rating. The valve driver modules shall be equipped with current sensing control to offset thermal changes in solenoid performance and to detect open or short circuit conditions and protect against the latter by automatic interruption of current to the shorted output.

Cylinder momentary push button switches will provide on-off style control of the plow and dump body operations. Program settings will provide effective and independent flow trims for plow up-down, plow angle and dump up-down.

A two-axis cylinder proportioning joystick with dead man switch and pushbutton selection of equipment shall be provided. The joystick shall employ dual redundant hall-effect mechanisms, eliminating the wear of potentiometer or other contact mechanisms. In the event of failure of one hall-effect output a program adjustment to system controller will allow selection of the alternate channel. The same controller will also provide electronic adjustment of one degree from center for operation, minimum valve drive at minimum joystick deflection, and maximum valve drive at maximum joystick deflection. Adjustments for degrees from center operation and the minimum valve drive at minimum joystick deflection will be independent for the plow and dump. The joystick shall plug to the control panel as its only connection point. Connection of the joystick will render the pushbutton cylinder controls inoperable. Conversely, disconnection of the joystick will reactivate the pushbutton controls. Selection of the equipment function by pushbuttons on the head of the joystick will illuminate an equipment identity label on the control panel. No operation of the joystick can take place without holding the dead man switch.

The spreader controls modes of operation shall provide a selectable automatic and manual control. There shall be a Blast operation with programmable selection of level and time. A Pause operation shall be available to momentarily disable the spreader operation.

A feedback sensor shall not be required to achieve accurate and consistent operation of the spreader functions. High brightness LED numerical displays will be used to indicate one of 11 reference controls positions for the spinner and auger (manual mode). In Auto operation the auger display will indicate "pounds per mile" if the system has been calibrated for such.

The system shall display fault occurrences of shorted or open outputs at the valves with indication of which circuit is responsible.

All controls will be mounted in the truck cab. The joystick shall be mounted on a pedestal style mechanism beside the driver at a level and location that is comfortable to operate, allowing the driver to operate at a glance without taking his eyes completely off the road. The Control display panel shall be mounted in the dash area and at a level easily viewed by the driver.

An integral valve/tank enclosure assembly shall be mounted to the frame rail of the vehicle. The reservoir and dry compartment shall be made of 7-gauge mild powder coated steel and the lid assembly shall be made of 10-gauge mild powder coated steel painted black to match the frame rails.

The bottom portion of the valve/tank integral design shall house a minimum of 35-gallons of hydraulic oil with temperature/sight gauge mounted on the front face. The reservoir shall be properly baffled with a drain plug in the bottom and provision in the top for an in-tank, glass type return line filter. There shall also be a fill tube vented cap assembly that will also serve as a clean out port. The filter will be a minimum of 10 micron and the element shall be easily removed for replacement.

The top portion of the valve/tank assembly will be dry with a rubber seal that will provide protection when the lid assembly is in place. This area will house the tube/vented cap, return line in-tank filter, the solenoid control valve manifold, and the PLC electronic command modules.



The solenoid control manifold valve will mount in the enclosure against the back wall allowing for all cylinder and spreader hose connections to be mounted directly to this assembly. The back of the manifold assembly will be bolted to the back wall in a way to prevent outside contamination and to allow for the O ring fittings for hose connections to the direct entry eliminating the need for internal cylinder and spreader hose plumbing. The valve/tank assembly shall be narrow or stepped from the frame of the vehicle to allow for ample room for installation and servicing of the hoses.

The PLC modules will be contained to the back wall of the enclosure and will allow for easy servicing. The wiring from the manifold cartridge solenoids will plug into these two modules and the power, ground, and ground speed control conductors will exit the enclosure with a strain relief sealed connector.

The lid will set on a perimeter gasket and will be retained with four over-center chrome latches for easy access and removal. The entire valve/tank enclosure will be mounted to the frame in a cradle fabricated by the installer to properly support the assembly.

**ITEM 33: 11 Cubic Yard Dump Body Steel Hydraulic RIP-RAP Bed - 120" CA.  
(11-14 Yard Range with Sideboards)**

| Item                            | Specifications (Minimum)  | Bidder's Proposal  |
|---------------------------------|---|--|
| <b>General Description:</b>     | This Specification shall provide for steel hydraulic dump beds new, the latest current production model. Complete with manufacturer's standard equipment and accessories, fully serviced ready to operate. To include manufacturer's certificate or warranty. (Warranty shall be the standard for the industry as offered to the public.) This body shall be equipment to meet all Federal and State of Oklahoma Safety Standards and Requirement. No dealer advertisement shall be affixed to the bed. | <u>Describe:</u><br>_____<br>_____<br>_____<br>_____<br>_____<br>_____ |
| <b>Body Size:<br/>Capacity:</b> | 11-yard sides and 14-yard ends.   | <u>Describe:</u><br>_____  |
| <b>Length:</b>                  | 14-feet.  | <u>Describe:</u><br>_____  |
| <b>Width:</b>                   | 84-inch inside width.   | <u>Describe:</u><br>_____  |
| <b>Head Height:</b>             | 62-inches.  | <u>Describe:</u><br>_____  |
| <b>Tail Gate Height:</b>        | 54-inches.  | <u>Describe:</u><br>_____  |
| <b>Side Height:</b>             | 42-inch, 4-bend (boxed) top rail, continuous steel with dirt shedding top.  | <u>Describe:</u><br>_____<br>_____                                     |
| <b>Steel Thickness:</b>         | 1/4-inch, AR400, Certified 145,000 psi yield for floor, sides, front and tailgate. All welds to be continuous.  | <u>Describe:</u><br>_____<br>_____                                     |
| <b>NOTE:</b>                    | Understructure to be "western" Crossmemberless design with tubular long sills. Long sills will be 100,000 psi yield strength steel with internal bracing, 8-gauge Inner and 8-gauge outer.  | <u>Describe:</u><br>_____<br>_____<br>_____                            |
| <b>Floor:</b>                   | Approx. 26-inch radius floor to sidewall for easy cleanout. Must have Approx. 37-inches flat floor in center.   | <u>Describe:</u><br>_____<br>_____<br>_____                            |

|                                   |   |   |
|-----------------------------------|---|---|
| <b>Top Rail:</b>                  | Boxed top rail will be 4 bend dirt shedding 5.5-inches x 8-inches.  | <u>Describe:</u><br>_____<br>_____                            |
| <b>Fenders:</b>                   | Sides shall have tandem steel fenders 9-feet forward from the rear, sloped 30-degrees outward.  | <u>Describe:</u><br>_____<br>_____                            |
| <b>Longitudinals:</b>             | 8-inches under structure height.  | <u>Describe:</u><br>_____                                     |
| <b>Corner Posts Rear:</b>         | Two (2) each, 12 3/4-inches, full depth with extra braces, dirt shedding top.   | <u>Describe:</u><br>_____<br>_____                            |
| <b>Tailgate Chains:</b>           | Two (2) each.   | <u>Describe:</u><br>_____                                     |
| <b>Grab Handles:</b>              | Two (2) each, one on each side of gate.   | <u>Describe:</u><br>_____                                     |
| <b>Clearance Lights:</b>          | Federal Motor Vehicle Safety Standard, LED clearance lights plus LED Stop/turn lights flush mounted in the rear corner pillars, shock resistant rubber mounted. Wiring-joints soldered and shrink wrapped with loom covering.   | <u>Describe:</u><br>_____<br>_____<br>_____<br>_____          |
| <b>Base Weight:</b>               | Show base weight of body.<br>(Without hoist & accessories).   | <u>Describe:</u><br>_____<br>_____                            |
| <b>Reflectors:</b>                | Six (6) each, two (2) each side, two (2) rear mounted on 3-inch dia. End gate, ICC approved, Federal #108, lighting to apply. <b>NOTE:</b> These reflectors must be housed type with screw or bolt type mounting stick-on type is not acceptable. Install Conspicuity tape on the rear on the bed. 12-feet minimum. | <u>Describe:</u><br>_____<br>_____<br>_____<br>_____<br>_____ |
| <b>Tail Gate:</b>                 | Panel fabricated from 1/4-inch, high strength steel with typical yield strength of 145,000 psi tailgate fully boxed upper, lower and vertical frames. Two (2) additional horizontal braces, sloped to shed dirt. All welds continuous.  | <u>Describe:</u><br>_____<br>_____<br>_____<br>_____          |
| <b>Banjo Eyes:</b>                | Four (4), two (2) each side 3/8-inch steel, 4 3/8-inch x 5-inches and extend beyond rear post.  | <u>Describe:</u><br>_____<br>_____                            |
| <b>Brackets &amp; Mud Flaps:</b>  | Two (2), 30-inches x 5inches, 1/8-inch-thick Steel (See Manufacturer's Instructions). Two (2)-One (1) on each side, 24-inches x 30-inches Non-Sail type. To be without any advertisement.   | <u>Describe:</u><br>_____<br>_____<br>_____                   |
| <b>Strobes, Front &amp; Rear:</b> | Furnish and install two (2) strobes on each side in rear corner pillars per Item 5 of IFB and two strobes in front grill area.  | <u>Describe:</u><br>_____<br>_____                            |
| <b>Warranty:</b>                  | Body manufacturer shall provide a written 5-year warranty covering repair or replacement of the body, hoist and air cylinder for defective material and/or workmanship. Warranty shall include all freight and labor  | <u>Describe:</u><br>_____<br>_____<br>_____                   |

|   |  |  |
|---|--|--|
|   | for repairs or replacement. Warranty shall also include adherence of primer to all metal surfaces not including inside or understructure of dump bodies. <b>The manufacturer's warranty must be submitted with Bid.</b>  | _____<br>_____<br>_____  |
| <b>Note:</b>                                      | Warranty labor and parts replacement must be handled by an in-state authorized dealer, who can provide immediate replacement without charge or delay. "See Specification Header at beginning of Bid Specifications".   | <u>Describe:</u><br>_____<br>_____<br>_____  |
| <b>Tail Gate Hardware:</b>                        | Upper tailgate hinges shall be off set forward 10" and shall have 1 1/2-inch pivot pins with zerk lubrication. Lower latch pins shall be 1 1/4-inches. Air tailgate release with in-cab controls.  | <u>Describe:</u><br>_____<br>_____<br>_____  |
| <b>NOTE:</b>                                      | When tailgate is hinged from the bottom, it must not have a gap where material can fall out.   | <u>Describe:</u><br>_____<br>_____   |
| <b>Folding Ladder</b>                             | Qty of Two (2), 20-inch, 4-inch-wide metal grip strut steps attached on the front right-hand side of the body. Install a slide out, two (2) rung ladder, mounted under the body just below the steps. The slide out ladder shall be on a hinged mechanism that has a positive latch system and will be locked in storage mode or when retracted out will hinge down and be locked in a stable configuration for safe utilization and accessible from the ground. The steps and the 2 rung ladder will allow access from the ground to the top of the body. | <u>Describe:</u><br>_____<br>_____<br>_____<br>_____<br>_____<br>_____<br>_____<br>_____ |
| <b>Mounting Height:</b>                           | Not to exceed 8-inch mounting height from top of truck frame to floor of body.   | <u>Describe:</u><br>_____<br>_____   |
| <b>Full Cab Shield:</b>                           | FULL cab shield, Full width of bed.  | <u>Describe:</u><br>_____<br>_____   |
| <b>Safety Strut:</b>                              | All dump beds must be equipped with Safety Strut to hold bed in the "UP" position while repairs are being made. (One each side).   | <u>Describe:</u><br>_____<br>_____<br>_____  |
| <b>Spreader Tie Down "D" Rings</b>                | Install four (4), 1/2-inch dia. "D" Rings on approximately 30-inches down from top rail; two (2) on each side with one (1) mounted 24-inches from the front and one mounted 24-inches from the rear of body. Must have the capability of ratcheting the spreader chains from a standing position on the ground.  | <u>Describe:</u><br>_____<br>_____<br>_____<br>_____<br>_____                            |
| <b>Electric Tarp</b>                              | Donovan 7000ELD electric tarp kit or approved equal with control box. A wind deflector- 16-gauge galvanized steel. A 3/16-inch removeable plate shall be installed over the top of the tarp roll up mechanism to protect it from damage.   | <u>Describe:</u><br>_____<br>_____<br>_____<br>_____                                     |
| <b>Hydraulic Hoist, Pump &amp; Control Valve:</b> | Class 110  | <u>Describe:</u><br>_____<br>_____   |

|  |   |  |
|--|---|--|
| <b>Cylinder:</b>                         | Show inside diameter & piston diameter and stroke _____" 1st active sleeve, _____", 2nd, _____" 3rd, _____" and base tube ___" stroke, single acting, self-adjusting V-type packing interior guide bushing, chrome plated cylinders.  | Describe:<br>_____<br>_____<br>_____                                     |
| <b>Hoist Capacity</b>                    | 38-tons.  | Describe:<br>_____   |
| <b>Dump Angle:</b>                       | 50-Degrees Maximum.   | Describe:<br>_____   |
| <b>Bleeder Valve:</b>                    | At top of base sleeve, auto bleed.  | Describe:<br>_____   |
| <b>Oil Reservoir:</b>                    | Capacity 28-gallons with filtered return line, include shut off valve, sight gauge. Mount to outside frame.   | Describe:<br>_____<br>_____  |
| <b>Low Hydraulic Fluid Warning Light</b> | Must install in the cab a Low Hydraulic Fluid Warning Light within easy view of driver.   | Describe:<br>_____<br>_____  |
| <b>Rear Pivot Hinges</b>                 | Double shear type - 2 hinge pins 1-3/4-inch x 8-inch.   | Describe:<br>_____   |
| <b>Hydraulic Pump</b>                    | 20 GPM @ 2,500 PSI @ 1,000 RPM. Pump to be mounted directly on PTO.   | Describe:<br>_____<br>_____  |
| <b>Relief Valve:</b>                     | Built into valve.   | Describe:<br>_____   |
| <b>Shaft Bearings:</b>                   | Roller Bearings Standard.   | Describe:<br>_____   |
| <b>Control Valve:</b>                    | 4 Position (raised, hold, feather, and lower) direct mounted on the reservoir.  | Describe:<br>_____<br>_____  |
| <b>Controls:</b>                         | Locking lever pedestal control with <u>Body Up</u> audio and visual alarm. A locking device to lock controls in neutral position shall be provided. Connect lever and valve with a 1/4-inch sealed cable. Valve to be Gresen model V-20.  | Describe:<br>_____<br>_____<br>_____<br>_____                            |
| <b>Power Take-Off:</b>                   | Direct driven from transmission to hydraulic pump. PTO to have enabler capability (i.e. "Hot Shift" Type) with electronic "overspeed protection" to prevent PTO from turning at more RPM than system is designed to handle. Must be geared to allow continuous operation at 0-30 MPH. Electronic dash mounted controls with engagement light, no levers or cables, must be able to shift PTO while truck is in motion 15 to 20 MPH. | Describe:<br>_____<br>_____<br>_____<br>_____<br>_____<br>_____<br>_____ |
| <b>Over Speed Protection for PTO</b>     | Fully adjustable from 300 to 3000 RPM.  | Describe:<br>_____   |

| Options |  | Describe:                                       |
|---------|--|---|
|         | 1. <u>Central Hydraulic System with Quick Disconnect:</u> Muncie MP2 central hydraulic system or acceptable equal capable of operating the dump body hoist, snow plow up/down/left/right and sand spreader spinner and conveyor. (see specification below). NOTE: Spreaders with water system will not currently fit RIP RAP bodies.   | 1<br>_____<br>_____<br>_____<br>_____<br>_____  |
|         | 2. <u>Ball Hitch:</u> Reinforced trailer hitch mounted on a 5/8-inch plate, gusseted, with a Buyers or Kernis K300 2 5/16-inch ball hitch rated at 16,000 LB. Trailer safety rings are Crosby weldless links per Item 23 of this IFB to match capacity of hitch.   | 2<br>_____<br>_____<br>_____<br>_____<br>_____  |
|         | 3. <u>Pintle Hitch:</u> Reinforced trailer hitch mounted on a 5/8-inch plate, gusseted, with a 90,000 lb. pintle hitch, Holland PH210 or equal. Trailer safety rings are Crosby weldless links per Item 21 to match capacity of hitch. To include glad hands and 7-Way light connector. Air lines to have quick disconnect fittings behind air operated pintle hitch so hitch may be removed during certain operations of the dump truck such as spreader operations.  | 3<br>_____<br>_____<br>_____<br>_____<br>_____  |
|         | 4. <u>Toolbox:</u> Frame mounted toolbox, RKI H361818 or Equal.  | 4<br>_____<br>_____<br>_____<br>_____<br>_____  |
|         | 5. <u>Trailer Tow Pkg:</u> Complete trailer package for pulling air brake trailers. To include air lines plumbed to rear of frame from factory source. Furnish and install glad hands and 7-way electrical connector at rear of frame ready to use with a 6 to 7-way adaptor. Air couplers and electrical connections are to be mounted as high as possible in the hinge area and plumbed in such a way as to not interfere with dumping of the bed or sand spreader operation and to avoid contact when pulling trailers. | 5<br>_____<br>_____<br>_____<br>_____<br>_____  |
|         | 6. <u>Controls:</u> Air operated controls for raising and lowering dump bed. Controls shall be of the type to enable operator to feather the bed down.<br>** This system not required if installing a Central Hydraulic System with Quick Disconnect.  | 6<br>_____<br>_____<br>_____<br>_____<br>_____  |
|         | 7. <u>Hydraulic Tailgate:</u> Hydraulic tailgate lift cylinders located inside corner pillars to lift tailgate completely open with controls in cab.   | 7<br>_____<br>_____<br>_____<br>_____<br>_____  |
|         | 8. <u>Spread Apron:</u> 12-inch Spread Apron, 10-gauge Steel.  | 8<br>_____<br>_____<br>_____<br>_____<br>_____  |
|         | 9. <u>Steps:</u> Qty of two (2), 20-inch steps, 4-inch-wide metal grip strut located on the right front side corner of the body. No folding ladder.  | 9<br>_____<br>_____<br>_____<br>_____<br>_____  |
|         | 10. <u>Chain &amp; Boomer Rack:</u> Install a chain and boomer rack on the nose of the trailer. The rack shall have a bottom section for the chains to sit in. The rack shall be lockable to prevent theft of the chains and boomers. The rack shall hold approx. 10 chains and boomers. The rack shall be accessible to the   | 10<br>_____<br>_____<br>_____<br>_____<br>_____ |

|  |  |                         |
|--|--|-------------------------|
|  | <p>operator. MUST ADD 8-inches TO CA OF TRUCK TO MOUNT CHAIN RACK.</p> <p>11. <u>Sideboard Extensions:</u> Install 2-inch Oak boards tapered from front to rear of bed. Boards to be tapered so that the area from the front of the bed to allow smooth operation of a roll up type tarp system. The tailgate is filled.</p> | <hr/> <hr/> <hr/> <hr/> |
|--|--|-------------------------|

**TAILLIGHTS:** Taillights of vehicle are to be mounted on the outside of the truck frame. Taillights shall be installed within a protected bracket to prevent them from being knocked off accidentally. Lens should be protected with expanded metal.

**MOUNTING INSTRUCTIONS:** The front mounting brackets on each side of the frame shall be drilled and bolted, not welded to the truck frame. The hydraulic pump shall be direct mounted to the Power take off. The rear end of the truck frame to be cut the least amount to allow the bed to reach maximum dumping position. The truck frame shall be cut at a right angle or square cut rather than tapered. (The trimmed material must be left in the truck bed.)

The following requirements will be necessary if there is no safeguard to prevent the bed from being raised too high or beyond the return point of the hydraulic hoist cylinders:  
 Safety bed stop blocks of enough thickness to provide this protection must be mounted behind the bed hinges between the bed and truck frame.

**NOTE:** Seller must NOT remove identification plates or numbers on the truck. This especially applies to the truck transmission when power take-off installed. If, during installation, it becomes necessary to remove these plates or cover these numbers, they must be replaced in a visible location.

**ELECTRICAL WIRING:** Wiring to be in loom and properly secured to frame to prevent sagging. Upon completion of installation all connections, splices and wiring to be protected by all-weather insulation. This insulation material to be of sufficient quality to insure a life period of five (5) years.

**\*POWER TAKE OFF:** Must be the latest current model installed and/or adapted to fit the transmission. Mounting bolts or screws must provide adequate self-locking and sealing to insure against oil leaks and must keep housing firmly attached to transmission.

**FRONT CLEARANCE LIGHTS:** To be installed under the front lower corner.

**PAINT:** All exposed metal shall be primed and painted. The bed shall be sprayed or dipped with a protective metal primer, then be painted Factory White to match vehicle.

**Hydraulic Central Control System for Snow and Ice Equipment:** Install a Muncie MP2 central hydraulic system or acceptable equal capable of operating the dump body hoist, snow plow up/down/left/right and sand spreader spinner and conveyor.

The sand spreader system shall contain a 3/4" pressure line for the spinner and a 3/4" pressure line for the conveyor and a single 1" return line. These lines will be hard piped from the hoist area to the rear of the truck. The spinner quick connect shall be an Eaton #5602-12-12S or acceptable equal. The conveyor quick connect shall be an Eaton #5601-12-12S or acceptable equal. The return quick connect shall be an Eaton #5602-16-16S or acceptable equal. All quick connects must be compatible with existing quick connects of same size being utilized in the current fleet of trucks so all sand spreaders units are compatible with any truck utilized. All quick connects are to be mounted on the rear curbside of the dump body approximately 10" from the rear (contact a City of Tulsa representative for an exact location. All quick connects to have a protective cover. These quick connects shall be mounted so they will not interfere with dumping of the bed or with use of the Pintle Hitch.

The Hydraulic Valving shall be as follows. The circuit design shall include Load-Sensing communication from all valves. The valves shall be solenoid operated carriage style with a common manifold and rated IP69. There shall

be a flow priority to insure operation of the cylinder functions whenever the spreader is operating, and pump flow is critically low. All cylinders shall have proportional flow control on the power sequence to afford cylinder speed control. Pressure relief valves shall have an independent stem adjustable pressure protection included for the manifold inlet, the spreader, the downside of all double acting cylinders and plow angle cylinders. The plow lift valves shall be capable of four-way control and have a flow capacity of 15 GPM. The raise side of the circuit shall be rated for zero leakage. The plow angle valves shall be capable of four-way control and have a flow capacity of 15 GPM. Load Locking check valves) or Motor Spool design) shall be included as required to support the angling mechanism used. The dump hoist valves shall have a four-way control and have a flow capacity of 30 GPM.

Counterbalance control valves shall be included. The spreader proportional control valves for the auger, conveyor, and spinner motors shall have flow capacities of 15/7 GPM respectively. These valves shall be pressure compensated and parallel in their circuit architecture.

The System Controls commands to the system valves shall be digitally encoded and sent over the vehicles electrical system using only a 12-volt DC and ground connection at each end of the system.

The valve driver modules shall be housed in Deutsch boxes employ Deutsch connectors at solenoids or acceptable equal giving IP69 environmental rating. The valve driver modules shall be equipped with current sensing control to offset thermal changes in solenoid performance and to detect open or short circuit conditions and protect against the latter by automatic interruption of current to the shorted output.

Cylinder momentary push button switches will provide on-off style control of the plow and dump body operations. Program settings will provide effective and independent flow trims for plow up-down, plow angle and dump up-down.

A two-axis cylinder proportioning joystick with dead man switch and pushbutton selection of equipment shall be provided. The joystick shall employ dual redundant hall-effect mechanisms, eliminating the wear of potentiometer or other contact mechanisms. In the event of failure of one hall-effect output a program adjustment to system controller will allow selection of the alternate channel. The same controller will also provide electronic adjustment of one degree from center for operation, minimum valve drive at minimum joystick deflection, and maximum valve drive at maximum joystick deflection. Adjustments for degrees from center operation and the minimum valve drive at minimum joystick deflection will be independent for the plow and dump. The joystick shall plug to the control panel as its only connection point. Connection of the joystick will render the pushbutton cylinder controls inoperable. Conversely, disconnection of the joystick will reactivate the pushbutton controls. Selection of the equipment function by pushbuttons on the head of the joystick will illuminate an equipment identity label on the control panel. No operation of the joystick can take place without holding the dead man switch.

The spreader controls modes of operation shall provide a selectable automatic and manual control. There shall be a Blast operation with programmable selection of level and time. A Pause operation shall be available to momentarily disable the spreader operation.

A feedback sensor shall not be required to achieve accurate and consistent operation of the spreader functions. High brightness LED numerical displays will be used to indicate one of 11 reference controls positions for the spinner and auger (manual mode). In Auto operation the auger display will indicate "pounds per mile" if the system has been calibrated for such.

The system shall display fault occurrences of shorted or open outputs at the valves with indication of which circuit is responsible.

All controls will be mounted in the truck cab. The joystick shall be mounted on a pedestal style mechanism beside the driver at a level and location that is comfortable to operate, allowing the driver to operate at a glance without taking his eyes completely off the road. The Control display panel shall be mounted in the dash area and at a level easily viewed by the driver.

An integral valve/tank enclosure assembly shall be mounted to the frame rail of the vehicle. The reservoir and dry compartment shall be made of 7-gauge mild powder coated steel and the lid assembly shall be made of 10-gauge mild powder coated steel painted black to match the frame rails.

The bottom portion of the valve/tank integral design shall house a minimum of 35-gallons of hydraulic oil with temperature/sight gauge mounted on the front face. The reservoir shall be properly baffled with a drain plug in the bottom and provision in the top for an in-tank, glass type return line filter. There shall also be a fill tube vented cap assembly that will also serve as a clean out port. The filter will be a minimum of 10 micron and the element shall be easily removed for replacement.

The top portion of the valve/tank assembly will be dry with a rubber seal that will provide protection when the lid assembly is in place. This area will house the tube/vented cap, return line in-tank filter, the solenoid control valve manifold, and the PLC electronic command modules.

The solenoid control manifold valve will mount in the enclosure against the back wall allowing for all cylinder and spreader hose connections to be mounted directly to this assembly. The back of the manifold assembly will be bolted to the back wall in a way to prevent outside contamination and to allow for the O ring fittings for hose connections to the direct entry eliminating the need for internal cylinder and spreader hose plumbing. The valve/tank assembly shall be narrow or stepped from the frame of the vehicle to allow for ample room for installation and servicing of the hoses.

The PLC modules will be contained to the back wall of the enclosure and will allow for easy servicing. The wiring from the manifold cartridge solenoids will plug into these two modules and the power, ground, and ground speed control conductors will exit the enclosure with a strain relief sealed connector.

The lid will set on a perimeter gasket and will be retained with four over-center chrome latches for easy access and removal. The entire valve/tank enclosure will be mounted to the frame in a cradle fabricated by the installer to properly support the assembly.

**ITEM 34: 12 Cubic Yard Dump Body, Rip-Rap Bed - 126" CA.  
(12-16 Yard Range with Sideboards)**

| Item                            | SPECIFICATIONS (Minimum)  | Bidder's proposal   |
|---------------------------------|---|---|
| <b>General:</b>                 | This Specification shall provide for steel hydraulic Rip Rap dump beds new, the latest current production model. Complete with manufacturer's standard equipment and accessories, fully serviced ready to operate. To include manufacturer's certificate or warranty and be bid less all applicable State and Federal Taxes. This body shall be equipment to meet all Federal and State of Oklahoma Safety Standards and Requirements. No dealer advertisement shall be affixed to the bed. | <u>Describe:</u><br>_____<br>_____<br>_____<br>_____<br>_____<br>_____<br>_____ |
| <b>Body size:<br/>Capacity:</b> | 12-yards sides and 16-yard ends.  | <u>Describe:</u><br>_____   |
| <b>Length:</b>                  | 15-feet.  | <u>Describe:</u><br>_____   |
| <b>Width:</b>                   | 84-inch inside width.   | <u>Describe:</u><br>_____   |
| <b>Head Height:</b>             | 62-inches.  | <u>Describe:</u><br>_____   |
| <b>Tail Gate Height:</b>        | 54-inches.  | <u>Describe:</u><br>_____   |



|                           |   |  |
|---------------------------|---|--|
| <b>Side Height:</b>       | 42-inches, four (4)-bend (boxed) top rail, continuous steel with dirt shedding top.   | <u>Describe:</u><br>_____<br>_____                   |
| <b>Steel Thickness:</b>   | 1/4-inch, AR400, certified 145,000 psi yield for floor, sides, front and tailgate. All welds to be continuous.  | <u>Describe:</u><br>_____<br>_____                   |
| <b>NOTE:</b>              | Understructure to be "western" Crossmember less design with tubular long sills. Long sills will be 100,000 psi yield strength steel with internal bracing, 8-gauge inner and 8-gauge outer.   | <u>Describe:</u><br>_____<br>_____<br>_____          |
| <b>Floor:</b>             | Approx. 26-inch radius floor to sidewall for easy cleanout. Must have 37-inches (approx.) flat floor in center.   | <u>Describe:</u><br>_____<br>_____<br>_____          |
| <b>Top Rail:</b>          | Boxed top rail will be four (4) bend, dirt shedding 5.5-inches x 8-inches.  | <u>Describe:</u><br>_____<br>_____                   |
| <b>Fenders:</b>           | Sides shall have tandem steel fenders 9-feet forward from the rear, sloped 30-degrees outward.  | <u>Describe:</u><br>_____<br>_____                   |
| <b>Longitudinal:</b>      | 8-inch under structure height.  | <u>Describe:</u><br>_____<br>_____                   |
| <b>Corner Posts Rear:</b> | Two (2) each, 12 3/4-inches, full depth with extra braces, dirt shedding top.   | <u>Describe:</u><br>_____<br>_____                   |
| <b>Spreader Chains:</b>   | Two (2) each.   | <u>Describe:</u><br>_____<br>_____                   |
| <b>Grab Handles:</b>      | Two (2), one (1) on each side of gate.  | <u>Describe:</u><br>_____<br>_____                   |
| <b>Clearance Lights:</b>  | <u>Federal Motor Vehicle Safety Standard, LED clearance lights plus LED Stop/turn lights flush mounted in the rear corner pillars, shock resistant rubber mounted. Wiring-joints soldered and shrink wrapped with loom covering.</u>  | <u>Describe:</u><br>_____<br>_____<br>_____          |
| <b>Base Weight:</b>       | Show base weight of body.<br>(Without hoist & accessories)  | <u>Describe:</u><br>_____<br>_____                   |
| <b>Reflectors:</b>        | Six (6), two (2) each side, two (2) rear mounted on 3-inch dia. End gate, ICC approved, Federal #108, lighting to apply. <u>NOTE:</u> These reflectors must be housed type with screw or bolt type mounting stick-on type is not acceptable. Install Conspicuity tape on the rear on the bed. 12-feet minimum | <u>Describe:</u><br>_____<br>_____<br>_____<br>_____ |
| <b>Tail Gate:</b>         | Panel fabricated from 1/4-inch-high strength steel with typical yield strength of 145,000 psi tailgate fully boxed upper, lower and vertical frames. Two (2) additional horizontal braces, sloped to shed dirt. All welds continuous.   | <u>Describe:</u><br>_____<br>_____<br>_____<br>_____ |

|                                  |  |   |
|----------------------------------|--|---|
| <b>Banjo Eyes:</b>               | Four (4), two (2) each side 3/8-inch steel, 4 3/8-inch x 5-inch and extend beyond rear post.   | <u>Describe:</u><br>_____<br>_____  |
| <b>Strobes Front and Rear:</b>   | Furnish and install strobe system as outlined in Item 5 of this IFB on each side in rear corner pillars and in front grill area of truck.  | <u>Describe:</u><br>_____<br>_____  |
| <b>Warranty:</b>                 | Body manufacturer shall provide a written 5-year warranty covering repair or replacement of the body, hoist and air cylinder for defective material and/or workmanship. Warranty shall include all freight and labor for repairs or replacement. Warranty shall also include adherence of primer to all metal surfaces not including inside or understructure of dump bodies. <b>The manufacturer's warranty must be submitted with Bid.</b>   | <u>Describe:</u><br>_____<br>_____<br>_____<br>_____<br>_____<br>_____          |
| <b>Brackets &amp; Mud Flaps:</b> | Two (2), 30-inch x 5-inch, 1/8-inch-thick Steel. (See Manufacturer's Instructions) Two (2), One (1) on each side, 24-inches x 30-inches Non-Sail type. Located to the rear of the rear tandems. To be without any advertisement.   | <u>Describe:</u><br>_____<br>_____<br>_____<br>_____                            |
| <b>Tail Gate Hardware:</b>       | Upper tailgate hinges shall be off set forward 10-inches and shall have 1 1/2-inch pivot pins with zerk lubrication. Lower latch pins shall be 1 1/4-inches. Air tailgate release in cab control.  | <u>Describe:</u><br>_____<br>_____<br>_____                                     |
| <b>NOTE:</b>                     | When tailgate is hinged from the bottom, it must not have a gap where material can fall out.   | <u>Describe:</u><br>_____<br>_____  |
| <b>Folding Ladder</b>            | Qty of Two (2), 20-inch, 4-inch-wide metal grip strut steps attached on the front right-hand side of the body. Install a slide out, two (2) rung ladder, mounted under the body just below the steps. The slide out ladder shall be on a hinged mechanism that has a positive latch system and will be locked in storage mode or when retracted out will hinge down and be locked in a stable configuration for safe utilization and accessible from the ground. The steps and the 2 rung ladder will allow access from the ground to the top of the body. | <u>Describe:</u><br>_____<br>_____<br>_____<br>_____<br>_____<br>_____<br>_____ |
| <b>Mounting Height:</b>          | Not to exceed 8-inch mounting height from top of truck frame to floor of body.   | <u>Describe:</u><br>_____<br>_____  |
| <b>Full Cab Shield:</b>          | Full Cab shield approximately over truck cab mounted on front of dump bed full width. Horizontal portion shall have 5-degrees slope. Material will be 11-gauge, high strength steel with typical yield strength of 100,000 psi.  | <u>Describe:</u><br>_____<br>_____<br>_____                                     |

|   |   |  |
|---|---|--|
| <b>Safety Strut:</b>                              | All dump beds must be equipped with Safety Strut to hold bed in the "UP" position while repairs are being made. (One each side).  | <u>Describe:</u><br>_____<br>_____                   |
| <b>Spreader Tie Down "D" Rings</b>                | Install four (4), 1/2-inch dia. "D" Rings on approximately 30-inches down from top rail; Two (2) on each side with one mounted 24-inches from the front and one mounted 24-inches from the rear of body. Must have the capability of ratcheting the spreader chains from a standing position on the ground. | <u>Describe:</u><br>_____<br>_____<br>_____<br>_____ |
| <b>Electric Tarp Kit</b>                          | Donovan 7000ELD electric tarp kit or approved equal with control box. A wind deflector, 16-gauge galvanized steel, with a 3/16-inch removeable plate shall be installed over the top of the tarp roll up mechanism to protect it from damage.   | <u>Describe:</u><br>_____<br>_____<br>_____          |
| <b>Hydraulic Hoist, Pump &amp; Control Valve:</b> | Class 120   | <u>Describe:</u><br>_____                            |
| <b>Cylinder:</b>                                  | Show inside diameter & piston diameter and stroke _____", 1st active sleeve, _____" 2nd, _____", 3rd, _____" and base tube __" stroke, single acting, self-adjusting V-type packing interior guide bushing, chrome plated cylinder.   | <u>Describe:</u><br>_____<br>_____<br>_____          |
| <b>Hoist Capacity:</b>                            | 38-Tons.  | <u>Describe:</u><br>_____                            |
| <b>Dump Angle:</b>                                | 50-Degrees Maximum.   | <u>Describe:</u><br>_____                            |
| <b>Bleeder Valve:</b>                             | At top of base sleeve, auto bleed.  | <u>Describe:</u><br>_____                            |
| <b>Oil Reservoir:</b>                             | Capacity: 28-gallons with filtered return line, include shut off valve, sight gauge. Mount outside frame.   | <u>Describe:</u><br>_____<br>_____                   |
| <b>Low Hydraulic Fluid Warning Light</b>          | Must install in the cab a Low Hydraulic Fluid Warning Light within easy view of driver.   | <u>Describe:</u><br>_____<br>_____                   |
| <b>Rear Pivot Hinges:</b>                         | Double shear type – Two (2) hinge pins 1-3/4-inches x 8-inches.   | <u>Describe:</u><br>_____<br>_____                   |
| <b>Hydraulic Pump</b>                             | 20 GPM @ 2,500 PSI, 1,000 RPM, Pump to be mounted directly on PTO.  | <u>Describe:</u><br>_____<br>_____                   |
| <b>Relief Valve:</b>                              | Built into valve.   | <u>Describe:</u><br>_____                            |
| <b>Shaft Bearings:</b>                            | Roller Bearings Standard.   | <u>Describe:</u><br>_____                            |
| <b>Control Valve:</b>                             | 4 Position (raised, hold, feather, and lower).  | <u>Describe:</u><br>_____                            |



|  |  |   |
|--|--|---|
|  | <p>6. <u>Controls</u>: Air operated controls for raising and lowering dump bed. Controls shall be of the type to enable operator to feather the bed down.<br/>                 ** This system not required if installing a Central Hydraulic System with Quick Disconnect.</p> <p>7. <u>Hydraulic Tailgate</u>: Hydraulic tailgate lift cylinders located inside corner pillars to lift tailgate completely open with controls in cab.</p> <p>8. <u>Spread Apron</u>: 12-inch Spread Apron, 10-gauge steel.</p> <p>9. <u>Steps</u>: Qty of two (2), 20-inch steps, 4-inch-wide metal grip strut located on the right front side corner of the body. No folding ladder.</p> <p>10. <u>Chain &amp; Boomer Rack</u>: Install a chain and boomer rack on the nose of the trailer. The rack shall have a bottom section for the chains to sit in. The rack shall be lockable to prevent theft of the chains and boomers. The rack shall hold approx. 10 chains and boomers. The rack shall be accessible to the operator. Must add 8-inches to CA of truck to mount chain rack.</p> <p>11. <u>Sideboard Extensions</u>: Install 2-inch Oak boards tapered from front to rear of bed. Boards to be tapered so that the area from the front of the bed to allow smooth operation of a roll up type tarp system. The tailgate is filled.</p> | <p>6</p> <p>7</p> <p>8</p> <p>9</p> <p>10</p> <p>11</p> |
|--|--|---|

**TAILLIGHTS:** Taillights of vehicle are to be mounted on the outside of the truck frame. Taillights shall be installed within a protected bracket to prevent them from being knocked off accidentally. Lens should be protected with expanded metal.

**MOUNTING INSTRUCTIONS:** The front mounting brackets on each side of the frame shall be drilled and bolted, not welded to the truck frame. The hydraulic pump shall be direct mounted to the Power take off. The rear end of the truck frame to be cut the least amount to allow the bed to reach maximum dumping position. The truck frame shall be cut at a right angle or square cut rather than tapered. (The trimmed material must be left in the truck bed.)

The following requirements will be necessary if there is no safeguard to prevent the bed from being raised too high or beyond the return point of the hydraulic hoist cylinders:

Safety bed stop blocks of enough thickness to provide this protection must be mounted behind the bed hinges between the bed and truck frame.

**NOTE:** Seller must NOT remove identification plates or numbers on the truck. This especially applies to the truck transmission when power take-off installed. If, during installation, it becomes necessary to remove these plates or cover these numbers, they must be replaced in a visible location.

**ELECTRICAL WIRING:** Wiring to be in loom and properly secured to frame to prevent sagging. Upon completion of installation all connections, splices and wiring to be protected by all-weather insulation. This insulation material to be of sufficient quality to insure a life period of five (5) years.

**\*POWER TAKE OFF:** Must be the latest current model installed and/or adapted to fit the transmission. Mounting bolts or screws must provide adequate self-locking and sealing to insure against oil leaks and must keep housing firmly attached to transmission.

**FRONT CLEARANCE LIGHTS:** To be installed under the front lower corner.

**PAINT:** All exposed metal shall be primed and painted. The bed shall be sprayed or dipped with a protective metal primer, then be painted Factory White to match vehicle.

**Hydraulic Central Control System for Snow and Ice Equipment:** Install a Muncie MP2 central hydraulic system or acceptable equal capable of operating the dump body hoist, snow plow up/down/left/right and sand spreader spinner and conveyor.

The sand spreader system shall contain a 3/4" pressure line for the spinner and a 3/4" pressure line for the conveyor and a single 1" return line. These lines will be hard piped from the hoist area to the rear of the truck. The spinner quick connect shall be an Eaton #5602-12-12S or acceptable equal. The conveyor quick connect shall be an Eaton #5601-12-12S or acceptable equal. The return quick connect shall be an Eaton #5602-16-16S or acceptable equal. All quick connects must be compatible with existing quick connects of same size being utilized in the current fleet of trucks so all sand spreaders units are compatible with any truck utilized. All quick connects are to be mounted on the rear curbside of the dump body approximately 10" from the rear (contact a City of Tulsa representative for an exact location. All quick connects to have a protective cover. These quick connects shall be mounted so they will not interfere with dumping of the bed or with use of the Pintle Hitch.

The Hydraulic Valving shall be as follows. The circuit design shall include Load-Sensing communication from all valves. The valves shall be solenoid operated carriage style with a common manifold and rated IP69. There shall be a flow priority to insure operation of the cylinder functions whenever the spreader is operating, and pump flow is critically low. All cylinders shall have proportional flow control on the power sequence to afford cylinder speed control. Pressure relief valves shall have an independent stem adjustable pressure protection included for the manifold inlet, the spreader, the downside of all double acting cylinders and plow angle cylinders. The plow lift valves shall be capable of four-way control and have a flow capacity of 15 GPM. The raise side of the circuit shall be rated for zero leakage. The plow angle valves shall be capable of four-way control and have a flow capacity of 15 GPM. Load Locking check valves) or Motor Spool design) shall be included as required to support the angling mechanism used. The dump hoist valves shall have a four-way control and have a flow capacity of 30 GPM. Counterbalance control valves shall be included. The spreader proportional control valves for the auger, conveyor, and spinner motors shall have flow capacities of 15/7 GPM respectively. These valves shall be pressure compensated and parallel in their circuit architecture.

The System Controls commands to the system valves shall be digitally encoded and sent over the vehicles electrical system using only a 12-volt DC and ground connection at each end of the system.

The valve driver modules shall be housed in Deutsch boxes employ Deutsch connectors at solenoids or acceptable equal giving IP69 environmental rating. The valve driver modules shall be equipped with current sensing control to offset thermal changes in solenoid performance and to detect open or short circuit conditions and protect against the latter by automatic interruption of current to the shorted output.

Cylinder momentary push button switches will provide on-off style control of the plow and dump body operations. Program settings will provide effective and independent flow trims for plow up-down, plow angle and dump up-down.

A two-axis cylinder proportioning joystick with dead man switch and pushbutton selection of equipment shall be provided. The joystick shall employ dual redundant hall-effect mechanisms, eliminating the wear of potentiometer or other contact mechanisms. In the event of failure of one hall-effect output a program adjustment to system controller will allow selection of the alternate channel. The same controller will also provide electronic adjustment of one degree from center for operation, minimum valve drive at minimum joystick deflection, and maximum valve drive at maximum joystick deflection. Adjustments for degrees from center operation and the minimum valve drive at minimum joystick deflection will be independent for the plow and dump. The joystick shall plug to the control panel as its only connection point. Connection of the joystick will render the pushbutton cylinder controls inoperable. Conversely, disconnection of the joystick will reactivate the pushbutton controls. Selection of the equipment function by pushbuttons on the head of the joystick will illuminate an equipment identity label on the control panel. No operation of the joystick can take place without holding the dead man switch.

The spreader controls modes of operation shall provide a selectable automatic and manual control. There shall be a Blast operation with programmable selection of level and time. A Pause operation shall be available to momentarily disable the spreader operation.

A feedback sensor shall not be required to achieve accurate and consistent operation of the spreader functions. High brightness LED numerical displays will be used to indicate one of 11 reference controls positions for the spinner and auger (manual mode). In Auto operation the auger display will indicate “pounds per mile” if the system has been calibrated for such.

The system shall display fault occurrences of shorted or open outputs at the valves with indication of which circuit is responsible.

All controls will be mounted in the truck cab. The joystick shall be mounted on a pedestal style mechanism beside the driver at a level and location that is comfortable to operate, allowing the driver to operate at a glance without taking his eyes completely off the road. The Control display panel shall be mounted in the dash area and at a level easily viewed by the driver.

An integral valve/tank enclosure assembly shall be mounted to the frame rail of the vehicle. The reservoir and dry compartment shall be made of 7-gauge mild powder coated steel and the lid assembly shall be made of 10-gauge mild powder coated steel painted black to match the frame rails.

The bottom portion of the valve/tank integral design shall house a minimum of 35-gallons of hydraulic oil with temperature/sight gauge mounted on the front face. The reservoir shall be properly baffled with a drain plug in the bottom and provision in the top for an in-tank, glass type return line filter. There shall also be a fill tube vented cap assembly that will also serve as a clean out port. The filter will be a minimum of 10 micron and the element shall be easily removed for replacement.

The top portion of the valve/tank assembly will be dry with a rubber seal that will provide protection when the lid assembly is in place. This area will house the tube/vented cap, return line in-tank filter, the solenoid control valve manifold, and the PLC electronic command modules.

The solenoid control manifold valve will mount in the enclosure against the back wall allowing for all cylinder and spreader hose connections to be mounted directly to this assembly. The back of the manifold assembly will be bolted to the back wall in a way to prevent outside contamination and to allow for the O ring fittings for hose connections to the direct entry eliminating the need for internal cylinder and spreader hose plumbing. The valve/tank assembly shall be narrow or stepped from the frame of the vehicle to allow for ample room for installation and servicing of the hoses.

The PLC modules will be contained to the back wall of the enclosure and will allow for easy servicing. The wiring from the manifold cartridge solenoids will plug into these two modules and the power, ground, and ground speed control conductors will exit the enclosure with a strain relief sealed connector.

The lid will set on a perimeter gasket and will be retained with four over-center chrome latches for easy access and removal. The entire valve/tank enclosure will be mounted to the frame in a cradle fabricated by the installer to properly support the assembly.

**ITEM 35: 14 Cubic Yard Dump Body, Rip Rap Bed - 132” CA. Without Chain Rack (14-18 Yard Range with Sideboards)**

| Item            | SPECIFICATIONS (Minimum)  | Bidder's proposal                           |
|-----------------|---|---|
| <b>General:</b> | This Specification shall provide for Rip Rap steel hydraulic dump beds new, the latest current production model. Complete with manufacturer's standard equipment and accessories, fully serviced ready to operate. to include manufacturer's certificate or | <u>Describe:</u><br><hr/> <hr/> <hr/> <hr/> |

|                                 |  |  |
|---------------------------------|--|--|
|                                 | warranty. This body shall be equipment to meet all Federal and State of Oklahoma Safety Standards and Requirements. No dealer advertisement shall be affixed to the bed.   | _____<br>_____<br>_____  |
| <b>Body Size:<br/>Capacity:</b> | 14-yard sides and 18-yard ends.  | <u>Describe:</u><br>_____<br>_____   |
| <b>Length:</b>                  | 16-feet.   | <u>Describe:</u><br>_____<br>_____   |
| <b>Width:</b>                   | 84-inch inside width.  | <u>Describe:</u><br>_____<br>_____   |
| <b>Head Height:</b>             | 66-inches.   | <u>Describe:</u><br>_____<br>_____   |
| <b>Tail Gate Height:</b>        | 54-inches.   | <u>Describe:</u><br>_____<br>_____   |
| <b>Side Height:</b>             | 42-inch, four (4)-bend (boxed) top rail, continuous steel with dirt shedding top.  | <u>Describe:</u><br>_____<br>_____   |
| <b>Steel Thickness:</b>         | 1/4-inch, AR400, certified 145,000 psi yield for floor, sides, front and tailgate. All welds to be continuous.   | <u>Describe:</u><br>_____<br>_____   |
| <b>Folding Ladder</b>           | Qty of Two (2), 20-INCH, 4-inch-wide metal grip strut steps attached on the front right-hand side of the body. Install a slide out, two (2) rung ladder, mounted under the body just below the steps. The slide out ladder shall be on a hinged mechanism that has a positive latch system and will be locked in storage mode or when retracted out will hinge down and be locked in a stable configuration for safe utilization and accessible from the ground. The steps and the 2 rung ladder will allow access from the ground to the top of the body. | <u>Describe:</u><br>_____<br>_____<br>_____<br>_____<br>_____<br>_____<br>_____<br>_____<br>_____<br>_____ |
| <b>Note:</b>                    | Understructure to be "western" Crossmemberless design with tubular long sills. Long sills will be 100,000 psi yield strength steel with internal bracing, 8-gauge inner and 8-gauge outer.   | <u>Describe:</u><br>_____<br>_____<br>_____<br>_____   |
| <b>Floor:</b>                   | 26-inch, radius floor to sidewall for easy cleanout. Must have 37-inch flat floor in center.   | <u>Describe:</u><br>_____<br>_____   |
| <b>Top Rail:</b>                | Boxed top rail will be four (4) bend dirt shedding 5.5-inches x 8-inches.  | <u>Describe:</u><br>_____<br>_____   |
| <b>Fenders:</b>                 | Sides shall have tandem steel fenders 9-feet forward from the rear, sloped 30-degrees outward.   | <u>Describe:</u><br>_____<br>_____   |
| <b>Longitudinals:</b>           | 8-inch under structure height.   | <u>Describe:</u><br>_____<br>_____   |
| <b>Corner Posts<br/>Rear:</b>   | Two (2) each, 12 3/4-inch, full depth with extra braces, dirt shedding top.  | <u>Describe:</u><br>_____<br>_____   |
| <b>Spreader<br/>Chains:</b>     | Two (2) each.  | <u>Describe:</u><br>_____<br>_____   |



|                                  |  |   |
|----------------------------------|--|---|
| <b>Grab Handles:</b>             | Two (2), one (1) on each side of gate.   | <u>Describe:</u><br>_____<br>_____                            |
| <b>Clearance Lights:</b>         | Federal Motor Vehicle Safety Standard, LED clearance lights plus LED Stop/turn lights, flush mounted in the rear corner pillars, shock resistant rubber mounted. Wiring-joints soldered and shrink wrapped with loom covering.   | <u>Describe:</u><br>_____<br>_____<br>_____<br>_____          |
| <b>Base Weight:</b>              | Show base weight of body.<br>(Without hoist & accessories).  | <u>Describe:</u><br>_____<br>_____                            |
| <b>Reflectors:</b>               | Six (6), two (2) each side, two (2) rear mounted on 3-inch diameter. End gate, ICC approved, Federal #108, lighting to apply. <b>NOTE:</b> These reflectors must be housed type with screw or bolt type mounting stick-on type is not acceptable. Install Conspicuity tape on the rear on the bed. 12-feet minimum | <u>Describe:</u><br>_____<br>_____<br>_____<br>_____<br>_____ |
| <b>Tail Gate:</b>                | Panel fabricated from 1/4-inch-high strength steel with typical yield strength of 145,000 psi tailgate fully boxed upper, lower and vertical frames. Two (2) additional horizontal braces, sloped to shed dirt. All welds continuous.  | <u>Describe:</u><br>_____<br>_____<br>_____<br>_____          |
| <b>Banjo Eyes:</b>               | Four (4), two (2) each side. 3/8-inch steel, 4 3/8-inch x 5-inch and extend beyond rear post.  | <u>Describe:</u><br>_____<br>_____                            |
| <b>Warranty:</b>                 | Covers bed for defective material and/or workmanship at a rate of 100% for the first (3) years and at a rate of 50% for years 4 and 5.   | <u>Describe:</u><br>_____<br>_____<br>_____                   |
| <b>Brackets &amp; Mud Flaps:</b> | Two (2), 30-inch x 5-inch, 1/8-inch-thick Steel (See Manufacturer's Instructions). Two (2), One (1) on each side, 24-inches x 30-inches Non-Sail type. To be without any advertisement.  | <u>Describe:</u><br>_____<br>_____<br>_____<br>_____          |
| <b>Tail Gate Hardware:</b>       | Upper tailgate hinges shall be off set forward 10-inches and shall have 1 1/2-inch pivot pins with zerk lubrication. Lower latch pins shall be 1 1/4-inches. Air tailgate release in cab control.  | <u>Describe:</u><br>_____<br>_____<br>_____<br>_____          |
| <b>Note:</b>                     | When tailgate is hinged from the bottom, it must not have a gap where material can fall out.   | <u>Describe:</u><br>_____<br>_____                            |
| <b>Step:</b>                     | One (1), 20-inch, Step, two (2) rung, 4-inch-wide expanded metal located lower right front corner of body.   | <u>Describe:</u><br>_____<br>_____<br>_____                   |
| <b>Mounting Height:</b>          | Not to exceed 8-inch mounting height from top of truck frame to floor of body.   | <u>Describe:</u><br>_____<br>_____<br>_____                   |

|   |   |   |
|---|---|---|
| <b>Full Cab Shield:</b>                           | Full Cab shield, full width of bed to be mounted on front of dump bed full width. Horizontal portion shall have 5-degree slope. Material will be 11-gauge high strength steel with typical yield strength of 100,000 psi.   | <u>Describe:</u><br>_____<br>_____<br>_____                   |
| <b>Safety Strut:</b>                              | All dump beds must be equipped with Safety Strut to hold bed in the "UP" position while repairs are being made. (One each side).  | <u>Describe:</u><br>_____<br>_____<br>_____                   |
| <b>Spreader Tie Down "D" Rings</b>                | Install four (4), 1/2-inch dia. "D" Rings on approximately 30-inches down from top rail; two (2) on each side with one mounted 24-inches from the front and one mounted 24-inches from the rear of body. Must have the capability of ratcheting the spreader chains from a standing position on the ground. | <u>Describe:</u><br>_____<br>_____<br>_____<br>_____<br>_____ |
| <b>Strobes Front and Rear:</b>                    | Furnish and install strobe system as outlined in Item 5 of this IFB on each side in rear corner pillars and in front grill area of truck.   | <u>Describe:</u><br>_____<br>_____<br>_____                   |
| <b>Electric Tarp Kit</b>                          | Donovan 7000ELD electric tarp kit or approved equal with control box. A wind deflector- 16-gauge galvanized steel. A 3/16-inch removeable plate shall be installed over the top of the tarp roll up mechanism to protect it from damage.  | <u>Describe:</u><br>_____<br>_____<br>_____<br>_____          |
| <b>Hydraulic Hoist, Pump &amp; Control Valve:</b> | Class 120   | <u>Describe:</u><br>_____<br>_____                            |
| <b>Cylinder:</b>                                  | Show inside diameter & piston diameter and stroke _____", 1st active sleeve, _____" 2nd, _____", 3rd, _____" and base tube __" stroke, single acting, self-adjusting V-type packing interior guide bushing, chrome plated cylinder  | <u>Describe:</u><br>_____<br>_____<br>_____<br>_____          |
| <b>Hoist Capacity:</b>                            | 38-tons.  | <u>Describe:</u><br>_____<br>_____                            |
| <b>Dump Angle:</b>                                | 50-degrees Maximum.   | <u>Describe:</u><br>_____<br>_____                            |
| <b>Bleeder Valve:</b>                             | At top of base sleeve, auto bleed.  | <u>Describe:</u><br>_____<br>_____                            |
| <b>Oil Reservoir:</b>                             | Capacity: 28-gallons with filtered return line, include shut off valve, sight gauge. Mount outside frame.   | <u>Describe:</u><br>_____<br>_____<br>_____                   |
| <b>Low Hydraulic Fluid Warning Light</b>          | Must install in the cab a Low Hydraulic Fluid Warning Light within easy view of driver.   | <u>Describe:</u><br>_____<br>_____<br>_____                   |
| <b>Rear Pivot Hinges:</b>                         | Double shear type - 2 hinge pins 1-3/4inches x 8-inches.  | <u>Describe:</u><br>_____<br>_____<br>_____                   |
| <b>Hydraulic Pump</b>                             | 20 GPM @ 2,500 PSI, 1,000 RPM, Pump to be mounted directly on PTO.  | <u>Describe:</u><br>_____<br>_____<br>_____                   |





**FRONT CLEARANCE LIGHTS:** To be installed under the front lower corner.

**PAINT:** All exposed metal shall be primed and painted. The bed shall be sprayed or dipped with a protective metal primer, then be painted Factory White to match vehicle.

**Hydraulic Central Control System for Snow and Ice Equipment:** Install a Muncie MP2 central hydraulic system or acceptable equal capable of operating the dump body hoist, snow plow up/down/left/right and sand spreader spinner and conveyor.

The sand spreader system shall contain a 3/4" pressure line for the spinner and a 3/4" pressure line for the conveyor and a single 1" return line. These lines will be hard piped from the hoist area to the rear of the truck. The spinner quick connect shall be an Eaton #5602-12-12S or acceptable equal. The conveyor quick connect shall be an Eaton #5601-12-12S or acceptable equal. The return quick connect shall be an Eaton #5602-16-16S or acceptable equal. All quick connects must be compatible with existing quick connects of same size being utilized in the current fleet of trucks so all sand spreaders units are compatible with any truck utilized. All quick connects are to be mounted on the rear curbside of the dump body approximately 10" from the rear (contact a City of Tulsa representative for an exact location. All quick connects to have a protective cover. These quick connects shall be mounted so they will not interfere with dumping of the bed or with use of the Pintle Hitch.

The Hydraulic Valving shall be as follows. The circuit design shall include Load-Sensing communication from all valves. The valves shall be solenoid operated carriage style with a common manifold and rated IP69. There shall be a flow priority to insure operation of the cylinder functions whenever the spreader is operating, and pump flow is critically low. All cylinders shall have proportional flow control on the power sequence to afford cylinder speed control. Pressure relief valves shall have an independent stem adjustable pressure protection included for the manifold inlet, the spreader, the downside of all double acting cylinders and plow angle cylinders. The plow lift valves shall be capable of four-way control and have a flow capacity of 15 GPM. The raise side of the circuit shall be rated for zero leakage. The plow angle valves shall be capable of four-way control and have a flow capacity of 15 GPM. Load Locking check valves) or Motor Spool design) shall be included as required to support the angling mechanism used. The dump hoist valves shall have a four-way control and have a flow capacity of 30 GPM. Counterbalance control valves shall be included. The spreader proportional control valves for the auger, conveyor, and spinner motors shall have flow capacities of 15/7 GPM respectively. These valves shall be pressure compensated and parallel in their circuit architecture.

The System Controls commands to the system valves shall be digitally encoded and sent over the vehicles electrical system using only a 12-volt DC and ground connection at each end of the system.

The valve driver modules shall be housed in Deutsch boxes employ Deutsch connectors at solenoids or acceptable equal giving IP69 environmental rating. The valve driver modules shall be equipped with current sensing control to offset thermal changes in solenoid performance and to detect open or short circuit conditions and protect against the latter by automatic interruption of current to the shorted output.

Cylinder momentary push button switches will provide on-off style control of the plow and dump body operations. Program settings will provide effective and independent flow trims for plow up-down, plow angle and dump up-down.

A two-axis cylinder proportioning joystick with dead man switch and pushbutton selection of equipment shall be provided. The joystick shall employ dual redundant hall-effect mechanisms, eliminating the wear of potentiometer or other contact mechanisms. In the event of failure of one hall-effect output a program adjustment to system controller will allow selection of the alternate channel. The same controller will also provide electronic adjustment of one degree from center for operation, minimum valve drive at minimum joystick deflection, and maximum valve drive at maximum joystick deflection. Adjustments for degrees from center operation and the minimum valve drive at minimum joystick deflection will be independent for the plow and dump. The joystick shall plug to the control panel as its only connection point. Connection of the joystick will render the pushbutton cylinder controls inoperable. Conversely, disconnection of the joystick will reactivate the pushbutton controls. Selection of the equipment function by pushbuttons on the head of the joystick will illuminate an equipment identity label on the control panel. No operation of the joystick can take place without holding the dead man switch.

The spreader controls modes of operation shall provide a selectable automatic and manual control. There shall be a Blast operation with programmable selection of level and time. A Pause operation shall be available to momentarily disable the spreader operation.

A feedback sensor shall not be required to achieve accurate and consistent operation of the spreader functions. High brightness LED numerical displays will be used to indicate one of 11 reference controls positions for the spinner and auger (manual mode). In Auto operation the auger display will indicate "pounds per mile" if the system has been calibrated for such.

The system shall display fault occurrences of shorted or open outputs at the valves with indication of which circuit is responsible.

All controls will be mounted in the truck cab. The joystick shall be mounted on a pedestal style mechanism beside the driver at a level and location that is comfortable to operate, allowing the driver to operate at a glance without taking his eyes completely off the road. The Control display panel shall be mounted in the dash area and at a level easily viewed by the driver.

An integral valve/tank enclosure assembly shall be mounted to the frame rail of the vehicle. The reservoir and dry compartment shall be made of 7-gauge mild powder coated steel and the lid assembly shall be made of 10-gauge mild powder coated steel painted black to match the frame rails.

The bottom portion of the valve/tank integral design shall house a minimum of 35-gallons of hydraulic oil with temperature/sight gauge mounted on the front face. The reservoir shall be properly baffled with a drain plug in the bottom and provision in the top for an in-tank, glass type return line filter. There shall also be a fill tube vented cap assembly that will also serve as a clean out port. The filter will be a minimum of 10 micron and the element shall be easily removed for replacement.

The top portion of the valve/tank assembly will be dry with a rubber seal that will provide protection when the lid assembly is in place. This area will house the tube/vented cap, return line in-tank filter, the solenoid control valve manifold, and the PLC electronic command modules.

The solenoid control manifold valve will mount in the enclosure against the back wall allowing for all cylinder and spreader hose connections to be mounted directly to this assembly. The back of the manifold assembly will be bolted to the back wall in a way to prevent outside contamination and to allow for the O ring fittings for hose connections to the direct entry eliminating the need for internal cylinder and spreader hose plumbing. The valve/tank assembly shall be narrow or stepped from the frame of the vehicle to allow for ample room for installation and servicing of the hoses.

The PLC modules will be contained to the back wall of the enclosure and will allow for easy servicing. The wiring from the manifold cartridge solenoids will plug into these two modules and the power, ground, and ground speed control conductors will exit the enclosure with a strain relief sealed connector.

The lid will set on a perimeter gasket and will be retained with four over-center chrome latches for easy access and removal. The entire valve/tank enclosure will be mounted to the frame in a cradle fabricated by the installer to properly support the assembly.

### III. BID SUBMISSION INSTRUCTIONS AND INFORMATION

1. **Bidder Registration**: To ensure timely updates and alerts about business opportunities with the City, interested Bidders should register as a Bidder with the City. To register, interested Bidders should complete the City's online vendor registration form ([linked here](#)). If You have any questions, email Cheryl Quin at [purchasing@cityoftulsa.org](mailto:purchasing@cityoftulsa.org) or check the City's "[Selling to the City](#)" Website.
2. **Pre-Bid Conference**: If a pre-Bid conference is required, see the first page for time and location.  
**No Pre-Bid Conference**
3. **Questions and Concerns**: As You prepare Your Bid response, You may have questions or points of clarification around this Solicitation. Any questions or comments about this Invitation for Bid must be sent via e-mail to the buyer listed on the first page "Assigned Buyer" and be received at least **10 Days prior to the Bid Submission Date**. Please include the IFB Bid number (as indicated on the title page) on all communications. Bidders may only communicate with the City through the Assigned Buyer – communication with other City staff could result in disqualification.
4. **Issuing of Addenda**: The City may addend or amend its IFB at any time before the Bid Submission Date. In addition to registering as a Bidder with the City, Bidders can check the "Purchasing Bid Opportunities & Results" page on the City Website for the latest updates ([linked here](#)). Any such amendments shall become a part of the Agreement. You must acknowledge receipt of any Addenda or Amendments by writing in the issued Addenda numbers on Exhibit A – Delivery and Pricing. City may reject any Bid that fails to acknowledge any Addenda or Amendments.
5. **Submission and Receipt of Bids**: The City requires two completed Invitation for Bids: 1 Original and 1 Copy. Each must be clearly labeled on the front sheet indicating "Original" or "Copy." Use the Bidder Checklist to ensure Your Bid includes all required components. If a copy on electronic media is also required, the box below will be checked.

Electronic Copy also required.

**Bids must be received no later than 5:00 PM (CST) on the Bid Submission Date (see first page) and delivered to:**

**City of Tulsa - City Clerk's Office  
175 East 2<sup>nd</sup> Street, Suite 260  
Tulsa Oklahoma 74103**

Bids must be sealed and either mailed or delivered. The package, container, or envelope should contain both of Your completed Bids, the original and the copy. Please use the provided label on the last page of this IFB to clearly write the Bidder's legal name and Bid number on the outside of the package, container, or envelope. No faxed or emailed Bids will be considered.

Bids received after the stated date and time **will not be accepted**. The timestamp clock located at the City Clerk's Office on the second floor of City Hall at 175 East 2nd Street, Suite 260, Tulsa, Oklahoma, 74103 is the City's official bid clock for this IFB. Timeliness of Bid submittals will be determined using only this clock.

***Exceptions to Timeliness Requirement***

The Purchasing Agent, at his/her sole discretion, may make exceptions only for the following reasons:

- City Hall closed for business for part or all of the day on the date the response was due;
- If the Purchasing Agent deems it appropriate due to large-scale disruptions in supply chains and the transportation industry that may have prevented delivery as required;
- If documented weather conditions caused the late delivery. You must provide documentation of such weather to the satisfaction of the Purchasing Agent.

In the event that the Bid submittal is delivered after the time specified and does not meet the exceptions listed above, the Bid will not be accepted and the submittal envelope will not be opened.

The City will not be liable for delays in delivery of Bids to the City due to handling by the U.S. Postal Service, or any other type of delivery service. The City reserves the right to postpone the date and time for submittal of Bids at any time prior to the Bid Opening Date or to delay or reschedule the Bid Opening Date for its own convenience.

The City reserves the right to cancel, revise, or amend this IFB and associated bidding documents up to the time specified for receipt of Bids.

6. **Bid Opening**: All Bid openings are public and take place at 8:30 a.m. Thursday, the day after Bids are due. The Bid openings are held in the City of Tulsa Council Meeting Room, 175 East 2<sup>nd</sup> Street, 2<sup>nd</sup> Floor, Tulsa, Oklahoma.



## IV. BID EVALUATION AND AWARD

1. **Bid Evaluation**: The Assigned Buyer and departmental staff will work together to determine the winning Bid. Generally speaking, the Bid award will go to the **Lowest Secure Bidder: the Supply or Service that can best meet the City's needs at the lowest cost.** In addition to price and specifications, the Buyer and departmental staff may also evaluate Bidder history and experience, delivery time, maintenance requirements, and performance data, among other factors.
2. **Bid Rejection or Withdrawal**: The City may reject any or all Bids in whole or in part. Reasons a Bid may be rejected include, but are not limited to the following:
  - A submitted Bid does not contain all the necessary materials, signatures, and/or affidavits (listed on the included checklist);
  - The Bid does not meet specifications and requirements in some material way;
  - The Bidder holds outstanding debt to the City;
  - The Bidder adds additional terms and conditions that modify IFB requirements or attempt to limit Bidder's liability to the City.

City reserves the right to waive minor deficiencies of specifications, technicalities or informalities in a Bid, provided that the best interest of the City would be served without prejudice to the rights of other Bidders. Bid withdrawal, meanwhile, may only be accomplished by having an Authorized Agent request the withdrawal in person at the City Clerk's office before the City's close of business on the Bid Submission Date.

3. **Bid Award Recommendation and Appeal**: Upon confirming the Bid recommended for selection, the Assigned Buyer will email all participating Bidders a memo announcing the recommended Bid. This email will also share the time, date, and virtual meeting link for the Standard, Specifications, and Award (SSA) committee meeting where the Bid award recommendation will be reviewed.

If approved by SSA, the award recommendation is then sent to the Mayor for the Mayor's final approval. SSA meetings are held Thursdays at 8:30am in the City of Tulsa Council Meeting Room, 175 East 2<sup>nd</sup> Street, 2<sup>nd</sup> Floor, Tulsa, Oklahoma. The meeting will be held on a given Thursday at 8:30 am, depending on when the Bid award has been determined. During this meeting, Bidders who are not recommended for award can issue an appeal and ask that the Bid award be reconsidered. Bidders who are not recommended for award can also email the Assigned Buyer prior to the SSA meeting if they have any questions or concerns regarding the award recommendation.

If/when the Bid award is approved by the SSA committee, the City will make available on the City's Purchasing Website a summary of Bids received generally within 5 working days after the Bid Opening Date. After a Bid award is recommended to the Mayor, a copy of the Bid summary will be available in the City Clerk's Office. Bid results are not provided in response to telephone or email inquiries. All Bid awards are subject to Acceptance by the City.

**V. BID PROCESSING**

1. **Forms, Notice to Proceed, and Irrevocability of Offer:** If the City Accepts Your Bid, You will have ten (10) Days from notification of the Acceptance to provide a completed IRS form W-9. You cannot start work until authorized to do so by the Purchasing Agent or a representative.

Bidder understands and acknowledges that the offer submitted as the Bid is firm and irrevocable from the City’s close of business on the Bid Submission Date until the date the City Accepts the Bid or 365 Days after the Bid Opening Date, whichever is earlier.

2. **Purchase Order Without Contract:** If the successful Bid is less than One Hundred Thousand Dollars (\$100,000), the City, in its sole discretion, may Accept the Bid upon written approval of the Mayor rather than execute the Purchase Agreement. Instead, the City will purchase the Supplies and/or Services by issuing a purchase order. In any event, the terms of this IFB will govern the transaction and be enforceable by the City and Seller.

3. **Insurance:**

Yes:                       No:

Seller and its subcontractors must obtain at Seller’s expense and keep in effect so long as City is purchasing Supplies or Services from Seller pursuant to this Bid, policies of insurance in the minimum amounts set forth below and Workers’ Compensation and Employer’s Liability insurance in the statutory limits required by law.

|   |                    |
|---|--------------------|
| General Liability: personal injury and property damage, each occurrence | \$1,000,000.00     |
| Automobile Liability: Combined Single Limit (CSL), each occurrence      | \$1,000,000.00     |
| Workers’ Compensation   | (Statutory limits) |

**Seller’s insurer must be authorized to transact business in the State of Oklahoma.** Seller will have 10 Days after notification that its Bid was Accepted by the City to provide proof of coverage. The Certificate of Insurance must be completed with the following information:

- A. Your name
- B. Insurer’s name and address
- C. Policy number
- D. Liability coverage and amounts
- E. Commencement and expiration dates
- F. Signature of authorized agent of insurer
- G. Certificate Holder Information: City of Tulsa, 175 East 2nd St., Suite 260, Tulsa, OK 74103

Seller shall not cause any required insurance policy to be cancelled nor permit it to lapse. Failure of the Seller to comply with the insurance requirements may be deemed a breach of the contract.

4. **Bonding:**                      Yes:                       No:

5. **Federal Funding:**    Yes:                       No:

**6. References:** If the box is checked "Yes," References are **required**:

**Yes:**       **No:**       **If yes, number of references required:**   2  

For each reference, the following information must be included: Company Name, Contact Name, Address, Phone Number, E-Mail Address, and the supplies or services provided.

|   |                |
|---|----------------|
| Company Name:                                 | _____          |
| Contact Name:                                 | _____          |
| Address:                                      | _____          |
| Phone Number:                                 | (    ) _____   |
| Email Address:                                | _____          |
| Description of<br>Supplies/Services Provided: | _____<br>_____ |
| Company Name:                                 | _____          |
| Contact Name:                                 | _____          |
| Address:                                      | _____          |
| Phone Number:                                 | (    ) _____   |
| Email Address:                                | _____          |
| Description of<br>Supplies/Services Provided: | _____<br>_____ |

## VI. SAMPLE FORMS

### Certificate of Secretary

The undersigned \_\_\_\_\_ (Assistant) Secretary of \_\_\_\_\_, a \_\_\_\_\_ corporation, (the "Corporation") hereby certifies that the following is a true and correct copy of a Resolution duly adopted by the Board of Directors of the Corporation on the \_\_\_\_\_ day of \_\_\_\_\_, 20\_\_.

RESOLVED, that \_\_\_\_\_ is authorized to execute and enter bids, contracts, bonds, affidavits and any ancillary documents, on behalf of the Corporation.

The undersigned further certifies that this Resolution is in full force and effect as of the date of this Certificate and has not been amended, modified, revoked, or rescinded.

IN WITNESS WHEREOF, I have executed this Certificate this \_\_\_ day of \_\_\_\_\_, 20\_\_.

\_\_\_\_\_  
(Signature)

\_\_\_\_\_  
Printed Name

\_\_\_\_\_  
(Assistant) Secretary

---

### [NAME OF COMPANY], LLC

### Consent of Members

The undersigned, being all of the Members of [Name of Company], LLC, an Oklahoma Limited Liability Company, hereby authorize, consent to, approve and ratify the execution by \_\_\_\_\_ [name of Authorized Representative] on behalf of [Name of Company], LLC of bid proposals, contracts, affidavits and related documents in connection with [Name of Project] of the City of Tulsa.

DATED, this \_\_\_ day of \_\_\_\_\_, 20\_\_. [Date must be dated date authorized representative signed or up to 30 days before the authorized representative signed]

\_\_\_\_\_  
[Signature]

Name Printed: \_\_\_\_\_

\_\_\_\_\_  
Title

Name Printed: \_\_\_\_\_

\_\_\_\_\_  
[Title]

[ADD ADDITIONAL LINES FOR ADDITIONAL MEMBERS]

Disclaimer Statement: This form is made available for example purposes only and is not intended to be legal advice nor intended to be relied upon in lieu of consultation with an attorney."

## EXHIBIT A – DELIVERY AND PRICING

**Bidder’s Legal Name:** \_\_\_\_\_  
 (Must be Bidder’s company name as reflected on its organizational documents, filed with the state in which Bidder is organized)

**Delivery:** If Your Bid is Accepted, state the number of Days You need to deliver the Supplies and/or to begin providing Services: \_\_\_\_\_

You must be able to deliver the Supplies and/or Services as specified in Your Bid. Failure to do so may result in City terminating the Agreement and pursuing collection under any performance bond, as well as seeking any other damages to which it may be entitled in law or in equity.

**Pricing:**

Award of Bid may be made by sections, by individual items or whole Bid whichever is best for the City of Tulsa. You do not have to Bid all sections for Your Bid to be considered responsive, but to be considered for a section, all items in the section must be Bid.

| Item | Description                                      | Estimated Annual QTY | Unit Cost | Extended Cost |
|------|--|----------------------|-----------|---------------|
| 1    | 2,000 lb. Crane w/manual 5-foot 6-inch Boom      | 2                    | \$        | \$            |
|      | <b>Item 1 Total Extended Cost</b>                |                      |           | <b>\$</b>     |
| 2    | 2,000 lb. Crane w/7-foot Boom (Pedestal Mounted) | 1                    | \$        | \$            |
|      | Option 1, Power Rotation                         | 1                    | \$        | \$            |
|      | <b>Item 2 Total Extended Cost</b>                |                      |           | <b>\$</b>     |
| 3    | 3,200 lb. Crane                                  | 3                    | \$        | \$            |
|      | Option 1, Power Out/In, Up/Down Outriggers       | 3                    | \$        | \$            |
|      | Option 2, Remote Control System                  | 3                    | \$        | \$            |
|      | <b>Item 3 Total Extended Cost</b>                |                      |           | <b>\$</b>     |
| 4    | 5,000 lb. Crane                                  | 2                    | \$        | \$            |
|      | Option 1, Power In/Out, Up/Down Outriggers       | 2                    | \$        | \$            |
|      | <b>Item 4 Total Extended Cost</b>                |                      |           | <b>\$</b>     |
| 5    | <b>LED Strobe System</b>                         |                      |           |               |
|      | 5A, Front & Rear for Cars.                       | 2                    | \$        | \$            |

|          |  |    |    |           |
|----------|--|----|----|-----------|
|          | 5B, Front & Rear for Pickups.  | 10 | \$ | \$        |
|          | 5C, Front & Rear for Vans.   | 5  | \$ | \$        |
|          | 5D, Front & Rear for SUV's.  | 10 | \$ | \$        |
|          | 5E, Front & Rear for Trucks/Utility Service Bodies (8,500 -18,000 GVW)         | 10 | \$ | \$        |
|          | 5F, Front & Rear for Trucks/Utility Service Bodies (19,000 - 33,000 GVW)       | 10 | \$ | \$        |
|          | 5G, Front & Rear for Trucks/Contractors Beds (10,000 - 18,000 GVW)             | 10 | \$ | \$        |
|          | 5H, Front & Rear for Trucks/Contractors Beds (19,000 - 33,000 GVW)             | 10 | \$ | \$        |
|          | 5I, Front & Rear for Trucks/Stake Body Flatbeds (10,000 - 18,000 GVW)          | 10 | \$ | \$        |
|          | 5J, Front & Rear for Trucks/Stake Body Flatbeds (19,000 - 33,000 GVW)          | 10 | \$ | \$        |
|          | 5K, <b>FRONT ONLY</b> for Heavy Duty Cab & Chassis Trucks (33,000-120,000 GVW) | 10 | \$ | \$        |
|          | 5L, Rear Mount Only Dump Bodies & Service Bodies                               | 10 | \$ | \$        |
|          | 5M, Not Installed Item Rear Strobes  | 2  | \$ | \$        |
|          | 5N, Not Installed Front Strobes  | 2  | \$ | \$        |
|          | <b>Item 5 Extended Total</b>   |    |    | <b>\$</b> |
| <b>6</b> | <b>Toolboxes/Window Grills/Bow Brackets</b>                                    |    |    |           |
|          | 6A, Tool Chest Double Lid, Standard Size.                                      | 5  | \$ | \$        |
|          | 6B, Tool Chest Double Lid, Wide, Deep.   | 5  | \$ | \$        |
|          | 6C, Tool Chest Double lid, Wide.   | 5  | \$ | \$        |
|          | 6D, Tool Chests, Double Lid, Standard, Mid-Size Truck                          | 5  | \$ | \$        |
|          | 6E, Tool Chests, Single Lid, Standard Size                                     | 5  | \$ | \$        |
|          | 6F, Tool Chests, Single Lid, Low Profile, for Mid-Size Trucks                  | 5  | \$ | \$        |
|          | 6G, Tool Chests, Single Lid, Standard Size, for Mid-Size Trucks                | 5  | \$ | \$        |
|          | 6H, Tool Chests, Upper Side Box, 78x16 1/2x12 1/2                              | 5  | \$ | \$        |
|          | 6J, Tool Chests, Upper Side Box, 96x16 1/2x12 1/2                              | 5  | \$ | \$        |

|           |   |    |    |           |
|-----------|---|----|----|-----------|
|           | 6K, Tool Chests, Underbody Box, 96x 16 1/2 x 12 1/2, 2 door           | 5  | \$ | \$        |
|           | 6L, Tool Chests, Underbody Box, 24x18x18                              | 5  | \$ | \$        |
|           | 6M, Tool Chests, Underbody Box, 36x14x16                              | 5  | \$ | \$        |
|           | 6N, Tool Chests, Underbody Box, 36x18x18                              | 5  | \$ | \$        |
|           | 6O, Tool Chests, Underbody Box, 48x18x18                              | 5  | \$ | \$        |
|           | 6P, Tool Chests, Underbody Box, 60x18x18                              | 5  | \$ | \$        |
|           | 6Q, Tool Chests, 2-door, 96x18x18 mounted on top or stacked, Flatbed. | 5  | \$ | \$        |
|           | 6R, Tool Chests, Over-wheel Box, 51x13 3/16x8                         | 1  | \$ | \$        |
|           | 6S, Option 1, Window Grill, Mid-Size Truck                            | 2  | \$ | \$        |
|           | 6S, Option 2, Window Grill, Full Size Truck                           | 2  | \$ | \$        |
|           | 6S, Option 3, Window Grill, Service Body Truck                        | 2  | \$ | \$        |
|           | 6S, Option 4, Bow Bracket, 1/2 Ton Truck                              | 2  | \$ | \$        |
|           | 6S, Option 5, Bow Bracket, Super Duty Truck                           | 2  | \$ | \$        |
|           | 6S, Option 6, Bow Bracket, Service Body Truck                         | 2  | \$ | \$        |
|           | <b>Item 6 Total Extended Cost</b>                                     |    |    | <b>\$</b> |
| <b>7</b>  | <b>Fire Extinguisher</b>  | 10 | \$ | \$        |
|           | <b>Item 7 Total Extended Cost</b>                                     |    |    | <b>\$</b> |
| <b>8</b>  | <b>Safety Triangles</b>   | 10 | \$ | \$        |
|           | <b>Item 8 Total Extended Cost</b>                                     |    |    | <b>\$</b> |
| <b>9</b>  | <b>Backup Alarm</b>   | 10 | \$ | \$        |
|           | <b>Item 9 Total Extended Cost</b>                                     |    |    | <b>\$</b> |
| <b>10</b> | <b>Electric Brake Controller</b>                                      | 3  | \$ | \$        |
|           | <b>Item 10 Total Extended Cost</b>                                    |    |    | <b>\$</b> |
| <b>11</b> | <b>6 or 7-way Trailer Light Connector</b>                             |    |    |           |

|           |  |    |    |           |
|-----------|--|----|----|-----------|
|           | 11A, Cars  | 1  | \$ | \$        |
|           | 11B, Pickups   | 1  | \$ | \$        |
|           | 11C, Vans  | 1  | \$ | \$        |
|           | 11D, SUV's   | 1  | \$ | \$        |
|           | 11E, Utility Service Bodies  | 1  | \$ | \$        |
|           | 11F, Contractors Bed   | 1  | \$ | \$        |
|           | 11G, Stakeside/Flatbeds  | 1  | \$ | \$        |
|           | 11H, Dump Bodies   | 1  | \$ | \$        |
|           | 11I, 6-Way to 8-Way Adaptor  | 1  | \$ | \$        |
|           | <b>Item 11 Extended Cost Total</b>   |    |    | <b>\$</b> |
| <b>12</b> | <b>Hitch receiver Type</b>   |    |    |           |
|           | 12A. Cars, Class I, 2,000 lb.  | 1  | \$ | \$        |
|           | 12B. Vans, Class II, 3,500 lb.   | 2  | \$ | \$        |
|           | 12C. SUV's, Mid-size Pickups, Class II, 3,500 lb.                              | 1  | \$ | \$        |
|           | 12D. Pickups, Class III, 8,000 lb.   | 5  | \$ | \$        |
|           | 12E. Pickups, Class IV, 10,000 lb.   | 5  | \$ | \$        |
|           | 12F. Contractors Dump Beds, Class IV, 10,000 lb.                               | 4  | \$ | \$        |
|           | 12G. Utility Service Bodies, Class IV, 10,000 lb.                              | 10 | \$ | \$        |
|           | 12H. Flatbeds, Class IV, 10,000 lb.  | 2  | \$ | \$        |
|           | <b>ITEM 12 TOTAL EXTENDED COST</b>   |    |    | <b>\$</b> |
| <b>13</b> | <b>Pintle Hitch Combination</b>  |    |    |           |
|           | 13A. Pintle Hitch w/a 8,000 lb. Receiver Installed on 6,000 GVW Pickups.       | 2  | \$ | \$        |
|           | 13B. Pintle Hitch w/a 10,000 lb. Receiver Installed on 8,500 GVW Pickups.      | 2  | \$ | \$        |
|           | 13C. Pintle Hitch w/3,500 lb. Capacity Receiver Hitch w/Tongue & Ball on SUV'S | 2  | \$ | \$        |



|           |  |    |    |           |
|-----------|--|----|----|-----------|
|           | 13D. Pintle Hitch w/a 3,500 lb. Receiver Installed on Vans   | 2  | \$ | \$        |
|           | 13E. Pintle Hitch w/a 10,000 lb. Receiver Installed on Flatbeds, Contractor Bodies, Utility Service Bodies.                    | 2  | \$ | \$        |
|           | 13F. Pintle Hitch w/ a mounted on tongue only, NO HITCH.   | 2  | \$ | \$        |
|           | <b>Item 13 Total Extended Cost</b>   |    |    | <b>\$</b> |
| <b>14</b> | <b>Air Pintle Hitch (PH210) w/7-way Connector &amp; Glad Hands</b>   | 5  | \$ | \$        |
|           | <b>Item 14 Total Extended Cost</b>   |    |    | <b>\$</b> |
| <b>15</b> | <b>Lift Gates</b>  |    |    |           |
|           | 15A. 1,000 lb. for Mid-Size & Compact Pickups  | 3  | \$ | \$        |
|           | 15B. 1,000 lb. for ½ to ¾ Ton Pickups  | 3  | \$ | \$        |
|           | 15C. 1,300 lb. Standard Type Liftgate for 1-ton walkthrough vans, panel vans, delivery and cube vans, utility service bodies.  | 3  | \$ | \$        |
|           | 15D. 1,300 lb. Dump thru type Liftgate for 1-ton walkthrough vans, panel vans, delivery and cube vans, utility service bodies. | 3  | \$ | \$        |
|           | 15E. 1,300 lb. Standard Type Liftgate for stake bodies and contractor beds.  | 3  | \$ | \$        |
|           | 15F. 1,300 lb. Dump Thru type Liftgate for stake bodies and contractor beds.   | 3  | \$ | \$        |
|           | 15G. 1,600 lb. Standard type Liftgate for 1-ton walkthrough vans, panel vans, delivery and cube vans, utility service bodies.  | 3  | \$ | \$        |
|           | 15H. 1,600 lb. Dump thru type Liftgate for 1-ton walkthrough vans, panel vans, delivery and cube vans, utility service bodies. | 3  | \$ | \$        |
|           | 15I. 1,600 lb. Standard type Liftgate for Stake Bodies and Contractor Dump Beds.   | 3  | \$ | \$        |
|           | 15J. 1,600 lb. Dump thru type Liftgate for Stake Bodies and Contractor Dump Beds.  | 3  | \$ | \$        |
|           | <b>Item 15 Total Extended Cost</b>   |    |    | <b>\$</b> |
| <b>16</b> | <b>Non-Emergency Light Bar</b>   |    |    |           |
|           | 16A. Installed, Work Vehicle.  | 10 | \$ | \$        |
|           | 16B. NOT Installed, Work Vehicles.   | 1  | \$ | \$        |
|           | 16C, Installed Security Vehicles.  | 1  | \$ | \$        |
|           | 16D. NOT Installed, Security Vehicles.   | 1  | \$ | \$        |

|           |  |    |    |           |
|-----------|--|----|----|-----------|
|           | <b>ITEM 16 TOTAL EXTENDED COST</b>                                       |    |    | <b>\$</b> |
| <b>17</b> | 8 Light LED Traffic Advisor  | 5  | \$ | \$        |
|           | <b>ITEM 17 TOTAL EXTENDED COST</b>                                       |    |    | <b>\$</b> |
| <b>18</b> | <b>Bed Liners</b>  |    |    |           |
|           | 18A. Drop-in Hard Plastic, Full Size 8-Foot Bed.                         | 1  | \$ | \$        |
|           | 18B. Drop-in Hard Plastic, Full Size 6-foot Bed.                         | 1  | \$ | \$        |
|           | 18C. Drop-in Hard Plastic, Mid-Size Long Bed.                            | 1  | \$ | \$        |
|           | 18D. Drop-in Hard Plastic, Mid-Size Short Bed.                           | 1  | \$ | \$        |
|           | 18E. Rubber Mat, Full Size 8-Foot Bed.                                   | 1  | \$ | \$        |
|           | 18F. Rubber Mat, Full Size 6-foot Bed.                                   | 1  | \$ | \$        |
|           | 18G. Rubber Mat, Mid-Size Long Bed.                                      | 1  | \$ | \$        |
|           | 18H. Rubber Mat, Mid-Size Short Bed.                                     | 1  | \$ | \$        |
|           | 18I. Spray-In Bed Liner, Full Size 8-Foot Bed, spray under Rail.         | 10 | \$ | \$        |
|           | 18J. Spray-In Bed Liner, Full Size 6-Foot Bed, spray under Rail.         | 10 | \$ | \$        |
|           | 18K. Spray-In Bed Liner, Mid-Size Long Bed, spray under Rail.            | 3  | \$ | \$        |
|           | <b>Item 18 Total Extended Cost</b>                                       |    |    | <b>\$</b> |
| <b>19</b> | <b>8,000 lb. Winch</b>   |    |    |           |
|           | Option A. Pickups, 6,000 GVW to 9,500 lb. GVW                            | 5  | \$ | \$        |
|           | Option B. Heavy Duty Trucks, 9,600 GVW to 17,500 GVW                     | 2  | \$ | \$        |
|           | Option C. Heavy duty Trucks, 9,600 GVW to 17,500 GVW. Mounted in the bed | 1  | \$ | \$        |
|           | <b>Item 19 Total Extended Cost</b>                                       |    |    | <b>\$</b> |
| <b>20</b> | <b>2,400-Watt Inverter</b>   |    |    |           |
|           | Option 1, Mounted in Service Bodies.                                     | 1  | \$ | \$        |
|           | Option 2, Mounted in Cabs of Pickup Trucks & Cab Chassis Trucks.         | 1  | \$ | \$        |

|           |  |   |    |           |
|-----------|--|---|----|-----------|
|           | <b>Item 20 Total Extended Cost</b>   |   |    | <b>\$</b> |
| <b>21</b> | <b>Safety Chains &amp; Hooks</b>   |   |    |           |
|           | 21A. Class I, II, III  | 5 | \$ | \$        |
|           | 21B. Class IV  | 5 | \$ | \$        |
|           | 21C. Class V   | 2 | \$ | \$        |
|           | Sling Links  |   |    |           |
|           | 21D. Class I, II, III  | 2 | \$ | \$        |
|           | 21E. Class IV  | 2 | \$ | \$        |
|           | 21F. Class V   | 2 | \$ | \$        |
|           | <b>Item 21 Total Extended Cost</b>   |   |    | <b>\$</b> |
| <b>22</b> | <b>Conspicuity Tape</b>  | 5 | \$ | \$        |
|           | <b>Item 22 Total Extended Cost</b>   |   |    | <b>\$</b> |
| <b>23</b> | <b>Stake Bodies</b>  |   |    |           |
|           | 23A. 8'6" Body (56" CA)  | 1 | \$ | \$        |
|           | 23B. 9'6" Body (60" CA)  | 1 | \$ | \$        |
|           | 23C. 10'6" Body (84" CA)   | 1 | \$ | \$        |
|           | 23D. 12'6" Body (84" CA)   | 1 | \$ | \$        |
|           | 23E. 14'6" Body (108" CA)  | 1 | \$ | \$        |
|           | 23F. 16'6" Body (120" CA)  | 1 | \$ | \$        |
|           | 23G. 18'6" Body (120" CA)  | 1 | \$ | \$        |
|           | 23H. 20'6" Body (150" CA)  | 1 | \$ | \$        |
|           | 23I. 22'6" Body (150" CA)  | 1 | \$ | \$        |
|           | 23J. 24'6" Body (165" CA)  | 1 | \$ | \$        |
|           | Option 1. 14" high Steel Contractors sides.<br>(priced per foot, one side) | 1 | \$ | \$        |

|           |  |   |    |           |
|-----------|--|---|----|-----------|
|           | Option 2. 40" high Steel Stake Sides.<br>(priced per foot, one side) | 1 | \$ | \$        |
|           | Option 3. 2" Pine Floor.   | 1 | \$ | \$        |
|           | Option 4. 1 3/8" Apitong Floor<br>(Priced per foot)                  | 1 | \$ | \$        |
|           | Option 5. 3/16" Smooth Steel Floor.                                  | 1 | \$ | \$        |
|           | Option 6. Bulkhead.  | 1 | \$ | \$        |
|           | Option 7. 4" Tail Roller.  | 1 | \$ | \$        |
|           | Option 8. 4" solid Tail Pipe on Bed.                                 | 1 | \$ | \$        |
|           | Option 9. 1,300 lb. Liftgate.  | 1 | \$ | \$        |
|           | Option 10. Ratchet Straps (Each)                                     | 1 | \$ | \$        |
|           | Option 11. Floor reinforcement for 3,200 lb. Crane mounting.         | 1 | \$ | \$        |
|           | Option 12. Floor reinforcement for 5,000 lb. Crane mounting.         | 1 | \$ | \$        |
|           | <b>Item 23 Total Extended Cost</b>                                   |   |    | <b>\$</b> |
| <b>24</b> | <b>Contractors Dump Body</b>   |   |    |           |
|           | 24A. 8'6" Body (56" CA)  | 1 | \$ | \$        |
|           | 24B. 9'6" Body (60" CA)  | 1 | \$ | \$        |
|           | 24C. 10'6" Body (84" CA)   | 1 | \$ | \$        |
|           | 24D. 12'6" Body (84" CA)   | 1 | \$ | \$        |
|           | 24E. 14'6" Body (108" CA)  | 1 | \$ | \$        |
|           | 24F. 16'6" Body (120" CA)  | 1 | \$ | \$        |
|           | Option 1. 3/16" Steel Treadplate Floor.                              | 1 | \$ | \$        |
|           | Option 2. 3/16" Steel Smooth Floor.                                  | 1 | \$ | \$        |
|           | Option 3. 14" Steel Stake Sides w/ Tailgate.<br>(Priced per foot)    | 1 | \$ | \$        |
|           | <b>Item 24 Total Extended Cost</b>                                   |   |    | <b>\$</b> |
| <b>25</b> | <b>Utility Service Body</b>  |   |    |           |

|  |   |    |    |
|--|---|----|----|
| 25A. 96" Bed, "H" Model (56" CA) (Single Wheel)                    | 2 | \$ | \$ |
| 25B. 96" Bed, "V" Model (56" CA) (Single Wheel)                    | 2 | \$ | \$ |
| 25C. 96" Bed, Low Profile (56" CA)                                 | 2 | \$ | \$ |
| 25D. 108" Bed, (60" CA)  | 2 | \$ | \$ |
| 25E1, 108" Bed, Low Profile (60" CA) (Single Wheel)                | 2 | \$ | \$ |
| 25E2, 108" Bed, Low Profile (60" CA) (Dual Wheel)                  | 2 | \$ | \$ |
| 25F, 132" Bed, Model (84" CA)                                      | 2 | \$ | \$ |
| Option 1, Master Lock System                                       | 2 | \$ | \$ |
| Option 2, Bumper with Lift Gate Cutouts.                           | 2 | \$ | \$ |
| Option 3, Top Pak Top Opening 4' Deep Compartment.                 | 2 | \$ | \$ |
| Option 4, High Roof  | 1 | \$ | \$ |
| Option 4A, 108" Bed Model, 54" Roof.                               | 1 | \$ | \$ |
| Option 4B, 108" Bed Model, 60" Roof.                               | 1 | \$ | \$ |
| Option 4C, 108" Bed Model, 72" Roof.                               | 1 | \$ | \$ |
| Option 4D, 132" Bed Model, 54" Roof.                               | 1 | \$ | \$ |
| Option 4E, 132" Bed Model, 60" Roof.                               | 1 | \$ | \$ |
| Option 4F, 132" Bed Model, 72" Roof.                               | 1 | \$ | \$ |
| Option 4G, Roll-up Rear Door.                                      | 1 | \$ | \$ |
| Option 4H, Pair of Conduit Doors, one each side with High Roof.    | 1 | \$ | \$ |
| Option 4I, Overhead Ladder Rack.                                   | 1 | \$ | \$ |
| Option 4J, Side Mounted Ladder Rack.                               | 1 | \$ | \$ |
| Option 5, Right Rear Body Reinforcement for Mount 3,200 lb. Crane. | 2 | \$ | \$ |
| Option 6, Additional Shelving for 108" Body                        | 2 | \$ | \$ |
| Option 7, Additional Shelving for 132" Body                        | 2 | \$ | \$ |

|           |  |   |    |           |
|-----------|--|---|----|-----------|
|           | Option 8, Replace Shelving with Pull Out Drawers on 108" Body. | 2 | \$ | \$        |
|           | Option 9, Replace Shelving with Pull Out Drawers on 132" Body. | 2 | \$ | \$        |
|           | <b>Item 25 Total Extended Cost</b>                             |   |    | <b>\$</b> |
| <b>26</b> | <b>38,000 lb. Crane Body (84" CA)</b>                          |   |    |           |
|           | Option 1, Master Lock System                                   | 2 | \$ | \$        |
|           | Option 2, Additional Shelving Pkg for 38K Body.                | 2 | \$ | \$        |
|           | Option 3, Tool Tray.   | 2 | \$ | \$        |
|           | Option 4, Drop Well for Gas Bottles.                           | 2 | \$ | \$        |
|           | Option 5, Bottle Holders to secure Gas Bottles.                | 2 | \$ | \$        |
|           | Option 6, Compartment Lighting.                                | 2 | \$ | \$        |
|           | Option 7, 2 flood Lights.                                      | 2 | \$ | \$        |
|           | Option 8, Crane Boom Support.                                  | 2 | \$ | \$        |
|           | Option 9, 24" Work Bumper.                                     | 2 | \$ | \$        |
|           | Option 10, 12" Bumper.   | 2 | \$ | \$        |
|           | Option 11, 16,000 lb. Pintle Hitch.                            | 2 | \$ | \$        |
|           | Option 12, Valve Key Brackets.                                 | 2 | \$ | \$        |
|           | Option 13, Ladder Racks.                                       | 2 | \$ | \$        |
|           | <b>Item 26 Total Extended Cost</b>                             |   |    | <b>\$</b> |
| <b>27</b> | <b>50,000 lb. Crane Body</b>                                   |   |    |           |
|           | Option 1, Master Lock System                                   | 2 | \$ | \$        |
|           | Option 2, Additional Shelving Pkg for 50K Body.                | 2 | \$ | \$        |
|           | Option 3, Tool Tray.   | 2 | \$ | \$        |
|           | Option 4, Drop Well for Gas Bottles.                           | 2 | \$ | \$        |
|           | Option 5, Bottle Holders to secure Gas Bottles.                | 2 | \$ | \$        |

|           |   |   |    |    |
|-----------|---|---|----|----|
|           | Option 6, Compartment Lighting.                                     | 2 | \$ | \$ |
|           | Option 7, 2 Flood Lights.   | 2 | \$ | \$ |
|           | Option 8, Additional Flood Lights.                                  | 2 | \$ | \$ |
|           | Option 9, Crane Boom Support.                                       | 2 | \$ | \$ |
|           | Option 10, 24" Work Bumper.   | 2 | \$ | \$ |
|           | Option 11, Valve Key Brackets.                                      | 2 | \$ | \$ |
|           | Option 12, Ladder Brackets.   | 2 | \$ | \$ |
|           | Option 13, Pintle Hitch, 16,000 lb.                                 | 2 | \$ | \$ |
|           | Option 14, Air Pintle Hitch. 90,000 lb.                             | 2 | \$ | \$ |
|           | Option 15, Delete Drawers Compartment H.                            | 2 | \$ | \$ |
|           | Option 16, Slide Out Shelf in Compartment D & J.                    | 2 | \$ | \$ |
|           | Option 17A, Spray-on Liner, Cargo Area.                             | 2 | \$ | \$ |
|           | Option 17B, Spray-on Liner, Bumper rear body, tops of compartments. | 2 | \$ | \$ |
|           | Option 18, Lift Gate, 1,600 lb                                      | 1 | \$ | \$ |
|           | Option 19, Labor to Mount Lift Gate to 50K Body.                    | 1 | \$ | \$ |
|           | Option 20, Rotary Screw Compressor                                  | 1 | \$ | \$ |
|           | <b>Item 27 Total Extended Cost</b>                                  |   |    | \$ |
| <b>28</b> | <b>5 Cubic Yard Steel Dump Body</b>                                 |   |    |    |
|           | Option 1, Central Hydraulic System.                                 | 2 | \$ | \$ |
|           | Option 2, Spread Apron.   | 2 | \$ | \$ |
|           | Option 3, 16,000 lb. Pintle Ball Hitch.                             | 2 | \$ | \$ |
|           | Option 4, Toolbox.  | 2 | \$ | \$ |
|           | Option 5a, Rumber Side Boards.                                      | 2 | \$ | \$ |
|           | Option 5b, Steel Side Boards.                                       | 2 | \$ | \$ |

|           |   |   |    |           |
|-----------|---|---|----|-----------|
|           | Option 6, Air Controls for Raising Bed.<br><b>(NOT REQUIRED IF QK CONNECT HYD SYSTEM IS USED)</b> | 2 | \$ | \$        |
|           | Option 7, 20" Steps in Place of Ladder.   | 2 | \$ | \$        |
|           | <b>Item 28 Total Extended Cost</b>  |   |    | <b>\$</b> |
| <b>29</b> | <b>5 Cubic Yard Stainless Steel Dump Body</b>   |   |    |           |
|           | Option 1, Central Hydraulic System.   | 1 | \$ | \$        |
|           | Option 2, Spread Apron.   | 1 | \$ | \$        |
|           | Option 3, 16,000 lb. Pintle Ball Hitch.   | 1 | \$ | \$        |
|           | Option 4, Toolbox.  | 1 | \$ | \$        |
|           | Option 5a, Rumbar Side Boards.  | 1 | \$ | \$        |
|           | Option 5b, Steel Side Boards.   | 1 | \$ | \$        |
|           | Option 6, Air Controls for Raising Bed.<br><b>(NOT REQUIRED IF QK CONNECT HYD SYSTEM IS USED)</b> | 1 | \$ | \$        |
|           | <b>Item 29 Total Extended Cost</b>  |   |    | <b>\$</b> |
| <b>30</b> | <b>10 Cubic Yard Steel Dump Body (120" CA)</b>  |   |    |           |
|           | Option 1, Central Hydraulic System.   | 2 | \$ | \$        |
|           | Option 2, Spread Apron.   | 2 | \$ | \$        |
|           | Option 3, 16,000 lb. Pintle Ball Hitch.   | 2 | \$ | \$        |
|           | Option 4, Toolbox.  | 2 | \$ | \$        |
|           | Option 5a, Rumbar Side Boards.  | 2 | \$ | \$        |
|           | Option 5b, Steel Side Boards.   | 2 | \$ | \$        |
|           | Option 6, Air Controls for Raising Bed.<br><b>(NOT REQUIRED IF QK CONNECT HYD SYSTEM IS USED)</b> | 2 | \$ | \$        |
|           | Option 7, 1/4" Floor.   | 2 | \$ | \$        |
|           | Option 8, 20" Steps in Place of Ladder.   | 2 | \$ | \$        |
|           | <b>Item 30 Total Extended Cost</b>  |   |    | <b>\$</b> |



|           |   |   |    |           |
|-----------|---|---|----|-----------|
| <b>31</b> | <b>13 Cubic Yard Steel Dump Body (126" CA)</b>  |   |    |           |
|           | Option 1, Central Hydraulic System.   | 2 | \$ | \$        |
|           | Option 2, Spread Apron.   | 2 | \$ | \$        |
|           | Option 3, 16,000 lb. Pintle Ball Hitch.   | 2 | \$ | \$        |
|           | Option 4, Toolbox.  | 2 | \$ | \$        |
|           | Option 5a, Rumbar Side Boards.  | 2 | \$ | \$        |
|           | Option 5b, Steel Side Boards.   | 2 | \$ | \$        |
|           | Option 6, Air Controls for Raising Bed.<br><b>(NOT REQUIRED IF QK CONNECT HYD SYSTEM IS USED)</b> | 2 | \$ | \$        |
|           | Option 7, 1/4" Floor.   | 2 | \$ | \$        |
|           | Option 8, 20" Steps in Place of Ladder.   | 2 | \$ | \$        |
|           | <b>Item 31 Total Extended Cost</b>  |   |    | <b>\$</b> |
| <b>32</b> | <b>13 Cubic Yard Stainless Steel Dump Body (126" CA)</b>  |   |    |           |
|           | Option 1, Central Hydraulic System.   | 1 | \$ | \$        |
|           | Option 2, Spread Apron.   | 1 | \$ | \$        |
|           | Option 3, 16,000 lb. Pintle Ball Hitch.   | 1 | \$ | \$        |
|           | Option 4, Toolbox.  | 1 | \$ | \$        |
|           | Option 5a, Rumbar Side Boards.  | 1 | \$ | \$        |
|           | Option 5b, Steel Side Boards.   | 1 | \$ | \$        |
|           | Option 6, Air Controls for Raising Bed.<br><b>(NOT REQUIRED IF QK CONNECT HYD SYSTEM IS USED)</b> | 1 | \$ | \$        |
|           | Option 7, 1/4" Floor.   | 1 | \$ | \$        |
|           | Option 8, 20" Steps in Place of Ladder.   | 1 | \$ | \$        |
|           | <b>Item 32 Total Extended Cost</b>  |   |    | <b>\$</b> |
| <b>33</b> | <b>11 Cubic Yard Steel Rip Rap Dump Body. (126" CA)</b>   |   |    |           |
|           | Option 1, Central Hydraulic System.   | 2 | \$ | \$        |

|           |   |   |    |           |
|-----------|---|---|----|-----------|
|           | Option 2, Pintle Ball Hitch, 16,000 lb.   | 2 | \$ | \$        |
|           | Option 3, Pintle Hitch, 90,000 lb.  | 2 | \$ | \$        |
|           | Option 4, Toolbox.  | 2 | \$ | \$        |
|           | Option 5, Trailer tow Package.  | 2 | \$ | \$        |
|           | Option 6, Air Controls for Raising Bed.<br><b>(NOT REQUIRED IF QK CONNECT HYD SYSTEM IS USED)</b> | 2 | \$ | \$        |
|           | Option 7, Hydraulic Tail Gate.  | 2 | \$ | \$        |
|           | Option 8, Spread Apron.   | 2 | \$ | \$        |
|           | Option 9, 20" steps in place of ladder.   | 2 | \$ | \$        |
|           | Option 10, Chain & Boomer Rack. (Add 8" to Chassis CA)  | 2 | \$ | \$        |
|           | Option 11, 2" Oak Sideboard Extensions.   | 2 | \$ | \$        |
|           | <b>Item 33 Total Extended Cost</b>  |   |    | <b>\$</b> |
| <b>34</b> | <b>12 Cubic Yard Steel Rip Rap Dump Body. (126" CA)</b>   |   |    |           |
|           | Option 1, Central Hydraulic System.   | 2 | \$ | \$        |
|           | Option 2, Pintle Ball Hitch, 16,000 lb.   | 2 | \$ | \$        |
|           | Option 3, Pintle Hitch, 90,000 lb.  | 2 | \$ | \$        |
|           | Option 4, Toolbox.  | 2 | \$ | \$        |
|           | Option 5, Trailer tow Package.  | 2 | \$ | \$        |
|           | Option 6, Air Controls for Raising Bed.<br><b>(NOT REQUIRED IF QK CONNECT HYD SYSTEM IS USED)</b> | 2 | \$ | \$        |
|           | Option 7, Hydraulic Tail Gate.  | 2 | \$ | \$        |
|           | Option 8, Spread Apron.   | 2 | \$ | \$        |
|           | Option 9, 20" steps in place of ladder.   | 2 | \$ | \$        |
|           | Option 10, Chain & Boomer Rack. (Add 8" to Chassis CA)  | 2 | \$ | \$        |
|           | Option 11, 2" Oak Sideboard Extensions.   | 2 | \$ | \$        |
|           | <b>Item 34, Total Extended Cost</b>   |   |    | <b>\$</b> |

|   |  |                 |    |           |
|---|--|-----------------|----|-----------|
| <b>35</b>   | <b>14 Cubic Yard Steel Rip Rap Dump Body. (132" CA)</b>  |                 |    |           |
|   | Option 1, Central Hydraulic System.  | 2               | \$ | \$        |
|   | Option 2, Pintle Ball Hitch, 16,000 lb.  | 2               | \$ | \$        |
|   | Option 3, Pintle Hitch, 90,000 lb.   | 2               | \$ | \$        |
|   | Option 4, Toolbox.   | 2               | \$ | \$        |
|   | Option 5, Trailer tow Package.   | 2               | \$ | \$        |
|   | Option 6, Air Controls for Raising Bed. <b>(NOT REQUIRED IF QK CONNECT HYD SYSTEM IS USED)</b> | 2               | \$ | \$        |
|   | Option 7, Hydraulic Tail Gate.   | 2               | \$ | \$        |
|   | Option 8, Spread Apron.  | 2               | \$ | \$        |
|   | Option 9, 20" steps in place of ladder.  | 2               | \$ | \$        |
|   | Option 10, Chain & Boomer Rack. (Add 8" to Chassis CA)   | 2               | \$ | \$        |
|   | Option 11, 2" Oak Sideboard Extensions.  | 2               | \$ | \$        |
|   | <b>Item 35 Total Extended Cost</b>   |                 |    | <b>\$</b> |
| <b>TOTAL EXTENDED COST NOT TO EXCEED:</b><br>(All costs must be included, or Your Bid will be disqualified) |  | <b>\$</b> _____ |    |           |

**THE CITY DOES NOT GUARANTEE ANY SPECIFIC QUANTITY OR NUMBER OF PURCHASES, IF ANY, THAT WILL BE MADE DURING THE AGREEMENT TERM.**

**Annual Price Adjustment.** The prices bid for any Supplies and/or Services shall not increase during the first year of the term of the Agreement. However, if You anticipate that You will not be able to maintain firm prices after the first year of the term, You may request an annual change in price using one of the following methods:

- a. The increase is limited to the change in the Consumer Price Index from BLS Table 1\* (web link below) from the prior year
- b. Or the following fixed percentage: \_\_\_\_\_ %.

\*Web Link: <https://www.bls.gov/news.release/cpi.t01.htm>



**AFFIDAVIT**  
**NON-COLLUSION, INTEREST, AND CLAIMANT**

STATE OF \_\_\_\_\_ )  
 )ss.  
 COUNTY OF \_\_\_\_\_ )

I, \_\_\_\_\_, of lawful age, being first duly sworn, state that:  
**(Seller's Authorized Agent)**

1. I am the **Authorized Agent** of Seller herein for the purposes of certifying facts pertaining to the existence of collusion between and among Bidders and municipal officials or employees, as well as facts pertaining to the giving or offering of things of value to government personnel in return for special consideration in the letting of any contract pursuant to the proposal to which this statement is attached.
  2. I am fully aware of the facts and circumstances surrounding the making of Seller's Bid to which this statement is attached, and I have been personally and directly involved in the proceedings leading to the submission of such Bid; and
  3. Neither the Seller nor anyone subject to the Seller's direction or control has been a party:
    - a. to any collusion among Bidders in restraint of freedom of competition by agreement to respond at a fixed price or to refrain from responding,
    - b. to any collusion with any municipal official or employee as to quantity, quality, or price in the prospective contract, or as to any other terms of such prospective contract, nor
    - c. in any discussions between Bidders and any municipal official concerning exchange of money or other thing of value for special consideration in the letting of a contract.
  4. No officer or employee of the City of Tulsa either directly or indirectly owns a five percent (5%) interest or more in the Bidders business or such a percentage that constitutes a controlling interest. Affiant further states that the following officers and/or employees of the City of Tulsa own an interest in the Bidders business which is less than a controlling interest, either direct or indirect.
- 
5. All invoices to be submitted pursuant to this agreement with the City of Tulsa will be true and correct.
  6. That the work, services or material furnished will be completed or supplied in accordance with the plans, specifications, orders, requests or contract furnished or executed by the affiant. Affiant further states that (s)he has made no payment directly or indirectly to any elected official, officer or employee of the City of Tulsa or of any public trust where the City of Tulsa is a beneficiary, of money or any other thing of value to obtain payment of the invoice or procure the contract or purchase order pursuant to which an invoice is submitted. Affiant further certifies that (s)he has complied with all applicable laws regarding equal employment opportunity.

By: \_\_\_\_\_  
 Signature  
 Title: \_\_\_\_\_

Subscribed and sworn to before me this \_\_\_\_\_ day of \_\_\_\_\_, 20\_\_\_\_.

\_\_\_\_\_  
 Notary Public  
 My Commission Expires: \_\_\_\_\_  
 Notary Commission Number: \_\_\_\_\_

**The Affidavit must be signed by an **Authorized Agent** and notarized.**



## PURCHASE AGREEMENT

(Page 1 of 5)

**INSTRUCTIONS:** Bidder must properly sign and return this document or Bid may be **rejected**. Your signature on this document indicates You have read and understand these terms and conditions and agree to be bound by them.

**THIS PURCHASE AGREEMENT** is between the CITY OF TULSA, OKLAHOMA, a municipal corporation, 175 East 2<sup>nd</sup> Street, Tulsa, Oklahoma, 74103-3827 (the "City") and:

(Bidder's company name as reflected on its organizational documents filed with the state in which Bidder is organized; not simply DBA and address) (the "Seller").

### WITNESSETH:

WHEREAS, the City has approved certain specifications and advertised for or solicited Bids on the following supplies or services:

### **TAC 309F Secondary Source for Truck Bodies, Equipment & Accessories**

(the "Supplies and/or Services").

WHEREAS, Seller submitted a Bid and desires to provide the Supplies and/or Services to City;

WHEREAS, Seller acknowledges that its signature on this Purchase Agreement constitutes an irrevocable offer to provide the Supplies and/or Services specified in the Agreement and that if Accepted by the City's Mayor, this document will become the contract for such Supplies and/or Services.

NOW, THEREFORE, for and in consideration of the terms, covenants and conditions hereinafter set forth, the parties hereto agree as follows:

#### 1. Definitions.

- 1.1. **"Acceptance" or "Accepts"** with respect to a Bid means either (1) City's execution of the Purchase Agreement, or (2) Mayor's written approval of the Bid award recommendation and issuance of a purchase order on behalf of the City if the purchase is for an amount less than One Hundred Thousand Dollars (\$100,000) and the City determines it is in its best interests.
- 1.2. **"Acceptance"** with respect to delivery of the Supplies and/or Services shall mean City's written acknowledgment that Seller has satisfactorily provided such Supplies and/or Services as required.
- 1.3. **"Addenda" "Addendum" or Amendment(s)"** means a clarification, revision, addition, or deletion to the Invitation for Bid by City which will become a part of the agreement between the parties.
- 1.4. **"Agreement"** consists of the Invitation for Bid and the Purchase Agreement.
- 1.5. **"Bid Opening Date"** means the date the Bid is opened by the City.
- 1.6. **"Bid Submission Date"** means the date the Bid is due from Bidder to the City.
- 1.7. **"City"** means the City of Tulsa, Oklahoma.
- 1.8. **"Days"** means calendar days unless otherwise specified.
- 1.9. **"Invitation for Bid" or "IFB"** consists of the following documents: Cover page, Sections I-VI, Exhibit A – Delivery and Pricing, Affidavit(s), Purchase Agreement, and Bidder Checklist.
- 1.10. **"Primary Seller"** means the Seller whose Bid City Accepts as the principal seller of the Supplies and/or Services required.
- 1.11. **"Purchasing Ordinance"** means Tulsa Revised Ordinances, Title 6, Chapter 4 et seq.
- 1.12. **"Secondary Seller"** means the Seller whose Bid City Accepts as a back-up seller in the event the Primary Seller is unable to provide all the Supplies and/or Services.
- 1.13. **"Seller"** means the Bidder whose Bid City Accepts.
- 1.14. **"Specifications"** means the technical and/or performance requirements for the Supplies or Services.
- 1.15. **"You" or "Your"** means the Bidder responding to this Invitation for Bid or the Seller whose Bid the City Accepts.
- 1.16. **"Website"** means the City of Tulsa's website for the Purchasing Division: [www.cityoftulsa.org/purchasing](http://www.cityoftulsa.org/purchasing)

2. **Order of Precedence.** Capitalized terms used but not defined herein will have the respective meanings given to them in the Purchasing Ordinance. In the event of conflicting or ambiguous language between this Purchase Agreement, any of the other Agreement documents, and additional information submitted by the Seller and Accepted by City, the parties shall be governed first according to this Purchase Agreement, second according to the remainder of the documents included in the Agreement and third according to any additional information submitted by Seller and Accepted by City.

3. **Purchase and Sale.** Seller agrees to sell City the Supplies and/or Services for the price and upon the delivery terms set forth on Exhibit A – Delivery and Pricing. City agrees to pay Seller the price as set forth in Exhibit A based on (a) the quantity actually purchased in the case of Supplies and/or Services priced by unit, or (b) the total price for a stated quantity of Supplies and/or Services, upon (i) delivery of the Supplies and/or Services to the City, (ii) the City's Acceptance thereof, and (iii) Seller's submission and City's approval of a verified claim for the amount due. City shall not pay any late charges or fees.

## PURCHASE AGREEMENT

(Page 2 of 5)

4. **Term.** The term of the Agreement begins on the date the Mayor/Mayor Pro Tem of the City of Tulsa executes this Purchase Agreement and terminates one year from that date. City in its sole discretion may offer Seller an opportunity to renew this Agreement up to an additional four (4) one (1) year term(s). Seller understands and acknowledges that any future contracts or renewals are neither automatic nor implied by this Agreement. City's continuing purchase of the Supplies and/or Services set forth in this Agreement is subject to City's needs and to City's annual appropriation of sufficient funds in City's fiscal year (July 1<sup>st</sup> to June 30<sup>th</sup>) in which City purchases Supplies and/or Services. In the event City does not appropriate or budget sufficient funds to perform this Agreement, this Agreement is null and void without further action by City.

The City may extend the Agreement for ninety (90) days beyond a final renewal term at the price and upon the delivery terms set forth on Exhibit A – Delivery and Pricing. The City, at its sole option and to the extent allowable by law, may choose to exercise subsequent ninety (90) day extensions upon the price and upon the delivery terms set forth on Exhibit A – Delivery and Pricing to facilitate the finalization of related terms and conditions of a new award or as needed for transition to a new Seller.

5. **Supplies Warranty.** With respect to all Supplies to be delivered under this Agreement, Seller warrants to City that such Supplies will be of good materials and workmanship and free from defects and will conform to the Specifications provided by City. In addition, Seller shall assure that the Supplies purchased hereunder are covered by all available and applicable manufacturers' warranties for such Supplies and expressly agrees that it will be responsible for performing all warranty obligations set forth in the Specifications for the Supplies.
6. **Services Warranty.** With respect to all Services to be performed under this Agreement, Seller warrants that it shall perform the Services using personnel of required skill, experience, and qualifications and in a professional and workmanlike manner in accordance with generally recognized industry standards for similar services and in accordance with the Specifications provided by City.
7. **Warranty Period.** Seller agrees that all warranties set forth herein will remain in effect for a period of one (1) year from the date City Accepts the Supplies and/or Services, or as specified in the Specifications, whichever is later. Seller shall not disclaim or otherwise limit the express warranties set forth herein.
8. **Warranty Remedies.** City shall notify Seller if any of the Supplies and/or Services fails to meet the warranties set forth above. If the failure is with Supplies, then Seller shall promptly correct, repair or replace such Supplies at its sole expense and/or if the failure is with a Service, then Seller shall promptly reperform such Service at Seller's sole expense. Notwithstanding the foregoing, if City determines that such Supplies and/or Services are defective or non-conforming within the first thirty (30) Days after the date of Acceptance by City, then Seller at City's option shall refund the entire purchase price, and, in the case of Supplies, City shall promptly return such Supplies to Seller. Seller shall pay all expenses related to the return of such Supplies to Seller.
9. **Rejection, Seller Bears Risk.** All Supplies and Services purchased in the Agreement are subject to approval by the City. Rejection of Supplies or Services, resulting because of nonconformity to the terms, conditions, and Specifications of this Agreement, whether held by the City or returned, will be at Seller's risk and expense. Seller shall bear the risk of loss or damage at all times until the Acceptance of the Supplies or Services by City.
10. **Force Majeure.** Seller will not be responsible for delays in delivery of the Supplies or Services due to acts of God, government action or inaction, fire, war, or riot, provided Seller notifies the City immediately, in writing of such pending or actual delay. Normally, in the event of any such delays (acts of God, etc.) the date of delivery of the Supplies or Services will be extended for a period equal to the time lost due to the reason for delay.
11. **Conflict of Interest.** By signing this Purchase Agreement, Seller covenants that it has no direct or indirect pecuniary or proprietary interest, and that it shall not acquire an interest that conflicts in any manner or degree with the Supplies or Services required to be provided or performed under the Agreement. Furthermore, Seller shall not employ any person or agent having any such conflict of interest. In the event that the Seller or its agents, employees or representatives hereafter acquires such a conflict of interest, it shall immediately disclose such interest to the City and take action immediately to eliminate the conflict or to withdraw from this contract, as the City requests.
12. **No Indemnification by City.** Seller understands and acknowledges that City is a municipal corporation that is funded by its taxpayers to operate for the benefit of its citizens. Accordingly, and pursuant to Oklahoma law, City shall not indemnify nor hold Seller harmless for loss, damage, expense or liability arising from or related to this Agreement, including any attorneys' fees and costs. In addition, Seller shall not limit its liability to City for actual loss or direct damages for any claim based on a material breach of this Agreement. City reserves the right to pursue all legal and equitable remedies to which it may be entitled.
13. **Liability/Indemnification.** Seller shall hold City harmless for any loss, damage or claims arising from or related to its performance of the Agreement. Seller must exercise all reasonable and customary precautions to prevent any harm or loss to all persons and property related to the Agreement. Seller agrees to indemnify and hold the City harmless from all claims, demands, causes of action or suits of whatever nature arising out of the Supplies, Services, labor, or materials furnished by Seller or Seller's subcontractors under this Agreement. In addition, Seller agrees to indemnify, defend, and save harmless City and its officers, employees and agents from all suits and actions of any nature brought against them due to the use of patented appliances, products or processes provided by Seller hereunder. Seller shall pay all royalties and charges incident to such patents.

## PURCHASE AGREEMENT

(Page 3 of 5)

14. **No liens.** Pursuant to City's Charter (Art. XII, §5), no lien of any kind shall exist against any property of City. Seller shall deliver all Supplies to City free and clear of liens. Delivery by Seller to City of Supplies which are subject to liens shall be a material breach of the Agreement and all damages and costs incurred by City because of the existence of such liens shall be paid to City by Seller. At City's option, City may return such Supplies to Seller and Seller shall pay the cost of returning such Supplies and reimburse City for any payments made for such Supplies.
15. **No Insurance by City.** If City is leasing Supplies herein, City shall not be required to obtain insurance for Seller's property. Seller shall be solely responsible for any insurance it deems necessary. City is self-insured for its own negligence, subject to the limits of the Governmental Tort Claims Act (51 O.S. § 151 et seq.).
16. **No Confidentiality.** Seller understands and acknowledges that City is subject to the Oklahoma Open Records Act (51 O.S. §24A.1 et seq.) and therefore cannot assure the confidentiality of this Agreement or other information provided by Seller pursuant to this Agreement that would be inconsistent with City's compliance with its statutory requirements thereunder.
17. **Compliance with Laws.** Seller shall comply, and ensure its subcontractors used in the performance of this Agreement comply with all applicable federal, state and local laws, regulations and standards. Seller is responsible for any costs of such compliance. Seller certifies that it and all its subcontractors to be used in the performance of this Agreement are in compliance with 25 O.S. Sec. 1313 and participate in the Status Verification System. The Status Verification System is defined in 25 O.S. Sec. 1312 and includes but is not limited to the free Employee Verification Program (E-Verify) available at [www.dhs.gov/E-Verify](http://www.dhs.gov/E-Verify).
18. **Termination.** City, by written notice, may terminate this Agreement, in whole or in part, when such action is in the best interest of City. If City terminates this Agreement, City shall be liable only for payment for Supplies accepted and Services rendered prior to the effective date of termination. City's right to terminate this Agreement is cumulative to any other rights and remedies provided by law or by this Agreement.
19. **Payment.** Invoices should be e-mailed to the City of Tulsa – Accounts Payable at: [apinvoices@cityoftulsa.org](mailto:apinvoices@cityoftulsa.org). Payment will be made net 30 days after receipt of a properly submitted invoice or the City's Acceptance of the Supplies or Services, whichever is later.

Each invoice must be fully itemized, identifying Supplies provided and/or Services performed, and must bear the purchase order number assigned by the City.

The purchase order number shall appear on all invoices, packing lists, packages, shipping notices, instruction manuals and other written documents relating to the Supplies or Services. Packing lists shall be enclosed in each and every box or package shipped pursuant to this Agreement, indicating the content therein.

20. **Price Changes.** The parties understand and agree that the variables in Seller's cost of performance may fluctuate, but any change in Seller's cost of performance will not alter its obligations under this Agreement, nor excuse performance or delay on Seller's part. Notwithstanding the foregoing, after the first year of the term, the Seller may request a price increase in addition to any other price increase set forth in this Agreement. In its sole discretion, the City may approve the request if it determines that such price increase is in the City's best interest.
21. **Right to Audit.** Seller agrees that Seller's books, records, documents, accounting procedures, practices, price lists or any other items related to the Supplies and/or Services provided hereunder are subject to inspection, examination, and copying by City or its designees. City requires Seller to retain all records related to this Agreement for the duration of the term of this Agreement and a period of three years following completion and/or termination of the Agreement. If an audit, litigation or other action involving such records begins before the end of the three-year period, Seller shall maintain the records three years after the date that all issues arising out of the action are resolved or until the end of the three-year retention period, whichever is later.
22. **Notice.** Any notice, demand, or request required by or made pursuant to this Agreement will be deemed properly made if personally delivered in writing or deposited in the United States mail, postage prepaid, to the following:

To Seller:

To CITY:

Contact for Legal Notice as specified on Exhibit A – Delivery and Pricing form.  
City Clerk  
CITY OF TULSA, OKLAHOMA  
175 E. 2<sup>nd</sup> Street, Suite 260  
Tulsa, Oklahoma 74103

With a copy to:

Tulsa Purchasing Division  
175 E. 2<sup>nd</sup> Street, 15<sup>th</sup> Floor  
Tulsa, OK 74103

23. **Relationship of Parties.** The Seller is and shall always remain an independent contractor with respect to activities and conduct while engaged in the performance of services for the City under this Agreement. No employees, subcontractors or agents of the Seller will be deemed to be employees of the City for any purpose whatsoever, and none will be eligible to participate in any benefit program provided by the City for its employees. The Seller shall be solely responsible for the payment of all employee wages and



## PURCHASE AGREEMENT

(Page 4 of 5)

salaries, taxes, withholding payments, fringe benefits, insurance premiums, continuing education courses, materials or related expenses on behalf of its employees, subcontractors, and agents. Nothing in this Agreement will be construed to create a partnership, joint venture, or agency relationship among the parties. No party will have any right, power or authority to act as a legal representative of another party, and no party will have any power to obligate or bind another party, or to make any representations, express or implied, on behalf of or in the name of the other in any manner or for any purpose whatsoever.

24. **Third Parties.** This Agreement is between City and Seller and creates no right unto or duties to any other person. No person is or will be deemed a third-party beneficiary of this Agreement.
25. **Time of Essence.** City and Seller agree that time is deemed to be of the essence with respect to this Agreement. The Agreement is subject to cancellation by the City for Seller's failure to deliver on time. All deliveries are required F.O.B to the City's facilities. For any exception to the delivery date specified in the Agreement, Seller shall give prior written notification and obtain written approval from the City. The Acceptance by the City of later performance with or without objection or reservation shall neither waive the City's right to claim damages for such breach nor constitute a waiver of the requirements for the timely performance of any obligation remaining to be performed by Seller.
26. **Binding Effect.** This Agreement shall be binding upon City and Seller and their respective successors, heirs, legal representatives and permitted assigns.
27. **Headings.** The headings used herein are for convenience only and will not be used in interpreting this Agreement.
28. **Severability Provision.** If any term or provision herein is determined to be illegal or unenforceable, the remainder of this Agreement will not be affected thereby. It is the intention of the parties that if any provision is held to be illegal, invalid or unenforceable, there will be added in lieu thereof a provision as similar in terms to such provision as is possible to be legal, valid and enforceable.
29. **Governing Law and Venue.** This Agreement is executed in and shall be governed by and construed in accordance with the laws of the State of Oklahoma without regard to its choice of law principles, which shall be the forum for any lawsuits arising under this Agreement or incident thereto. The parties stipulate that venue is proper in a court of competent jurisdiction in Tulsa County, Oklahoma and each party waives any objection to such venue. City does not and will not agree to binding arbitration of any disputes.
30. **No Waiver.** A waiver of any breach of any provision of this Agreement shall not constitute or operate as a waiver of any other provision, nor shall any failure to enforce any provision hereof operate as a waiver of the enforcement of such provision or any other provision.
31. **Entire Agreement.** The entire agreement between City and Seller is contained in the Agreement. No verbal agreement between the parties is binding. Any scope of services, scope of work, quote, invoice, acknowledgment or other communication or other document issued by Seller in connection with this Agreement will be for the purposes of describing in greater detail the Supplies and/or Services (as applicable) to be provided. Seller's rejection or modification of the terms set forth in the City's IFB is void and of no effect, unless any such modification improves upon the City's terms or Specifications, in which case the improvement is accepted. Seller understands and acknowledges that if it adds terms and conditions to its Bid that are different from the terms set forth herein that City may reject the Bid as non-responsive.
32. **Amendment/No Assignment.** The Agreement may only be modified or amended in a writing signed by both parties. Notwithstanding anything to the contrary stated herein or in the attachments to this Agreement, no future agreements, revisions or modifications that may be required under this Agreement are effective or enforceable unless such terms, revisions or modifications have been reduced to writing and signed by City and Seller. Seller may not assign this Agreement or use subcontractors to provide the Supplies and/or Services without City's prior written consent. Seller shall not be entitled to any claim for extras of any kind or nature.
33. **Multiple Counterparts.** This Purchase Agreement may be executed in several counterparts, each of which will be deemed an original, but which together will constitute one and the same instrument.
34. **Interpretive Matters and Definitions.** The following interpretive matters shall be applicable to this Agreement:
  - 34.1. Unless the context otherwise requires: (a) all references to Sections are to Sections of or to this Agreement; (b) each term defined in this Agreement has the meaning assigned to it; (c) "or" is disjunctive but not necessarily exclusive; (d) words in a singular include the plural and vice versa. All references to "\$" or to dollar amounts shall be in lawful currency of the United States of America;
  - 34.2. No provision of this Agreement will be interpreted in favor of, or against, any of the parties hereto by reason of the extent to which such party or its counsel participated in the drafting thereof or by reason of the extent to which any such provision is inconsistent with any prior draft hereof or thereof;
  - 34.3. Any reference to any applicable laws will be deemed to include all rules and regulations promulgated thereunder and judicial interpretations thereof, unless the context requires otherwise;

## PURCHASE AGREEMENT

(Page 5 of 5)

- 34.4. The word “including” means “including, without limitation” and does not limit the preceding words or terms; and
- 34.5. All words used in this Agreement will be construed to be of such gender, number or tense as circumstances require.
35. **Equal Employment Opportunity.** Seller agrees to comply with all applicable laws regarding equal employment opportunity and nondiscrimination.
36. **Authority to Bind.** The undersigned individual states that s/he has authority to bind Seller to this Agreement, that s/he has read and understands the terms of this Agreement, and that Seller agrees to be bound by this Agreement.

**IMPORTANT NOTE: This document must be signed by Authorized Agent. FAILURE TO SUBMIT PROPERLY AUTHORIZED SIGNATURE MAY RESULT IN YOUR BID BEING REJECTED AS NONRESPONSIVE.**

IN WITNESS WHEREOF, this Agreement has been executed in multiple copies on the dates set forth below to be effective during the period recited above.

Seller Company Name: \_\_\_\_\_

**Sign Here ►** \_\_\_\_\_

ATTEST:

Printed Name: \_\_\_\_\_

Title: \_\_\_\_\_

\_\_\_\_\_  
Corporate Secretary

Date: \_\_\_\_\_

**CITY OF TULSA, OKLAHOMA,  
a municipal corporation,**

ATTEST:

By: \_\_\_\_\_

Mayor

\_\_\_\_\_  
City Clerk

Date: \_\_\_\_\_

APPROVED:

\_\_\_\_\_  
Assistant City Attorney

## BIDDER CHECKLIST

Use this checklist to ensure You have properly read and completed **all** documents listed below. This document (the IFB) contains all the following materials, which must be completed and returned to the City of Tulsa City Clerk’s Office in a mailed envelope with the affixed packing label (found on the last page). Each of these documents will form the resulting Agreement between the City and Seller.

Remember: Bids must be sealed and either mailed or delivered. Please use the provided label to clearly write the Bidder legal name and Bid number on the outside of the package, container, or envelope. The package, container, or envelope should contain both of Your completed Bids, the original and the copy. No faxed or emailed Bids will be considered. Unless otherwise stated herein, Bids received after the stated date and time **will not be accepted**.

Bidder’s Name: \_\_\_\_\_

| <b>BIDDER CHECKLIST</b>   |              |                  |
|---|--------------|------------------|
| <b>BIDDER DOCUMENTS</b>   | <b>PAGES</b> | <b>INCLUDED?</b> |
| Notice of Invitation for Bid (Cover page and Sections I-IV)   | 1-2, 111-113 |                  |
| Specifications  | 3-110        |                  |
| Certificate(s) of Insurance   | 114          |                  |
| References (if applicable)  | 115          |                  |
| Sample Forms  | 116          |                  |
| EXHIBIT A: Delivery and Pricing   | 117-132      |                  |
| Affidavits<br><b>Signatures of Authorized Agent and notarization required.</b><br><b>Reference Page 2: Authorized Agent</b>   | 133          |                  |
| Purchase Agreement<br><b>Complete legal name in first paragraph and signature block.</b><br><b>Signature by Authorized Agent required.</b><br><b>Reference Page 2: Authorized Agent</b> | 134-138      |                  |

**Top Left of Label**

**FROM: [Name]**

[Bidder's legal name]

[Street Address]

[City, State, Zip Code]

**PACKING LABEL**

**FROM:**

**City of Tulsa – City Clerk's Office**

175 East 2<sup>nd</sup> Street, Suite 260

Tulsa, OK, 74103

**Bidder Submission For:**

BID# TAC 309F

BID DESCRIPTION: Secondary Source Truck Bodies, Equipment & Accessories

Please affix this label on the package, container, or envelope containing Your two completed Bids: one labeled "Original," the other labeled "Copy." We recommend that both Bids (original and copy) be sent in the same envelope.

This label ensures that Your Bid will be sent to the correct office (City Clerk's) and that it is associated with the correct Solicitation (indicated by the Bid number). Bids must be sealed and either mailed or delivered to the City Clerk's Office. Bids must also be received no later than 5:00 PM (CST) on date listed on the first page of the IFB.